



48th
ANNUAL REPORT
2023-24



संशोधनेन संवृद्धिः

Vasantdada Sugar Institute



48th ANNUAL REPORT 2023-24



Vasantdada Sugar Institute

Manjari Bk., Pin 412 307; Dist. Pune, Maharashtra, India.

Phone: (020) 26902100, Fax: (020) 26902244

E-mail: admin@vsisugar.org.in

Website: www.vsisugar.com



Published by

Mr. Sambhaji Kadupatil
Director General

Editorial Committee

Dr. RV Dani
Mr. RA Chandgude
Dr. AD Kadlag
Dr. KS Konde
Dr. DS Nimbalkar
Dr. PS Deshmukh
Mr. AA Prabhavalkar
Dr. RM Devarumath

Designed by

Mr. Sanjay Dawari, VSI
and
United Multicolour Printers Private Limited

Printed by

United Multicolour Printers Private Limited
Shaniwar Peth, Pune - 411 030



CONTENTS

Particulars	Page No.
Foreword: President	01
Vice-President Perceives	03
From the Desk of Director General	04
About VSI	07
Board of Trustees	11
Governing Council	12
Committees	14
3 rd International Conference & Exhibition	15
Technical performance of Sugar Mills in Maharashtra Season 2023-24 (October to September)	18
Services	
Human Resource Development	24
Library	29
Agricultural Sciences and Technology	
Crop Improvement	32
Sugarcane Breeding	32
Tissue Culture	44
Molecular Biology and Genetic Engineering	49
Crop Production	50
Agronomy	50
Soil Science	52
Agricultural Microbiology	54
Agricultural Engineering	59
Agricultural Economics	59
Crop Protection	60
Entomology	60
Plant Pathology	63
Farm Development and Management	65
Sugar Technology	72
Sugar Engineering	82
Alcohol Technology and Biofuels	100
Environmental Sciences	112
Electronics and Computer	122
Instrumentation	126

ANNEXURES

No.	Particulars	Page No.
I	Awards of Excellence	130
	Technical Efficiency (Zone-wise)	130
	Cane Development and Financial Management	130
	Season-wise Highest Sugarcane Yield in the Zone and State	131
	Outstanding Performance	131
II	Membership of other Organizations	139
III	VSI Officials on Various Committees	140
IV	Publication	142
V	Seminars / Workshop / Training Programmes / Meetings	151
	I) Seminars / Workshop / Training Programmes Organized by VSI	151
	II) Participation in Seminars / Workshop / Webinars / Training Programmes by VSI Scientists	152
	III) Participation in Meetings by VSI Scientists	155
VI	Lectures Delivered by Visitors at VSI	158
VII	Invited Lectures by VSI Scientists	158
VIII	Radio and Television Programmes	160
IX	Awards, Ph.D. Award, Patents, MoU	161
X	Distinguished Visitors, Aboard Visits By VSI Staff	165
XI	Visit to Other Institutes	167
XII	Visits by Technical Personnel	168
XIII	Abbreviations and Acronyms	171



Inauguration of technical seminar on Cleaning of Sugarcane Crop by Mechanical Method
Mr. Sharad Pawar, Hon'ble President,
Vasantdada Sugar Institute, Pune



The meeting on collaboration between Oxford University and KVK, Baramati on 'Artificial intelligence in sugarcane agriculture' held at VSI



PRESIDENT FOREWORD



On the global sugar scenario, the world sugar output (raw values) for the 2023-24 season was 181.26 million tonnes, an increase of 3.46 million tonnes from the previous season. The stock-to-consumption ratio remained at 54.36%. Imports estimated at 68.29 million tonnes and exports at 68.56 million tonnes, 1.80% and 4.42% rise respectively. Consumption is expected to rise by 2.55 million tonnes to 181.46 million tonnes and closing stocks estimated at 98.64 million tonnes.

In 2023, global fuel ethanol production increased to 116652 million litres, registering a rise of 7.48% over the previous year. The United States with a production of 59436 million litres and Brazil with 35076 million litres are the top contributors. India ranked fourth, contributing about 5% of global fuel ethanol, by producing about 5852 million litres. Global fuel ethanol consumption was estimated at 108132 million litres, an increase of 2.95% over the previous year. India's consumption was estimated at 5088 million litres.

India has set a vision of becoming energy Atmanirbhar by 2047 and committed in its efforts towards achieving Net Zero emissions by 2070. Recently, ETHANOL100 fuel has been launched for customers at 183 Indian Oil Retail outlets in Maharashtra, Karnataka, Uttar Pradesh, Tamil Nadu and New Delhi. As on today, India achieved the target of around 14% blending of ethanol in fuel, working diligently and steadily towards achieving the target of 20% ethanol blending in fuel by 2025 under the Central Government's Ethanol Blending Programme (EBP). Total demand for ethanol is estimated to be around 13500 million litres per year. To meet the requirement, total ethanol production capacity of about 17000 million litres per year is needed by 2025, whereas,

India's current total production capacity stands at 16480 million litres. There is a need to augment production capacities with the sugar mills and necessary infrastructure and storage with the Oil Marketing Companies. During the season 2023-24, around 2.00 million tonnes equivalent of sugar was diverted for ethanol production using B-Heavy molasses, sugarcane juice and sugar syrup as a feedstock.

For the sugar industry, there is an opportunity for production of Sustainable Aviation Fuel (SAF) from sugarcane molasses as a feedstock. In an endeavor to achieve de-carbonization of the aviation sector and self-reliance, a target has been set to blend 1% SAF in Jet fuel by 2027 and 2% by 2028. Every year, the country would require around 140 million litres of SAF to blend 1% and 280 million litres to blend 2%.

The CBG Blending Obligation (CBO) has been promoted for the production and consumption of Compressed Bio-Gas (CBG) in the country, by setting up consumption targets of 1% by 2025-26 and 5% by 2028-29 onwards of total CNG/PNG consumption. CBO encourages investment and establishment of 750 CBG projects by 2028-29.

All these initiatives taken by the Central Govt. are intended to reduce the country's reliance on imported fuels, promote circular bio-economy and save invaluable foreign exchange and so also to reduce the carbon footprint and ultimately move towards achieving the goal of net zero emission. Therefore, this provide the Indian sugar industry an opportunity to venture into new areas such as ethanol, biofuels, Hydrogen, aviation fuel, etc. and augment their capacities as well as financial stability to make the sugar industry more sustainable.

VSI continues to lead in research and consultancy in sugar, ethanol, renewable energy and agriculture. Newly established regional centres in Patharwala (Jalna) and Nagpur cater to the needs of the sugar industry and sugarcane farmers in the Marathwada and Vidarbha regions. The Nagpur centre now covers a total of 69.73 hectares. Rapid developments such as land leveling for plantation of sugarcane breeders' seed and installation of drip irrigation system at the Patharwala and Nagpur centre sare completed and sugarcane has been planted. Disease free, healthy and genetically pure

seeds through three tier sugarcane seed programme is produced and distributed to the sugar mills and sugarcane growers for production of foundation and certified seed. Such seed multiplication will increase cane productivity by around 15% to 20%. Breeders' seed production programme was taken on an area of 33.28 ha under National Food Security Mission, AICRP on seed project and from Institute's fund. Plans are also under progress to setup similar regional centre to serve the Khandesh region of Maharashtra and also in Gujarat state.

The highlight of the year was pre-release of sugarcane variety CoVSI 18121, which is a mid-late maturing, high yielding, high in sugar content, non-lodging and has good ratoonability, which I am sure shall benefit the sugarcane growers of Maharashtra.

VSI has successfully organized the 3rd International Conference and Exhibition on "Sustainability: Challenges & Opportunities in the Global Sugar Industry" from 12th to 14th January 2024. The event was inaugurated by Shri Nitin Gadkari, Honorable Union Minister of Road Transport and Highways, Govt. of India. The inaugural session of the 3rd conference was attended by 2800 delegates from 28 countries. A total of 65 eminent speakers from 21 countries including Indian experts presented their scientific research papers, their insights and their views in 13 sessions on agricultural, financial and technical topics.

The goal of these triennial international conferences is to bring together industrialists, technicians, scientists, academicians and researchers connected to the sugar and allied industry. Such gathering facilitates the exchange of the latest scientific and technological advancements and inspires innovations and provides insights into latest machinery and processes used globally in projects like renewable energy, co-generation and distillation. This knowledge-sharing and adoption of novel technologies will help to improve the sugar mills in Maharashtra and across the country.

The event saw significant participation from 277 sponsors, showcasing new technologies such as machinery used in sugar mills, distilleries, co-generation plants and other allied industries. So also agricultural implements related to field operation, harvesters, planters, solar, drones, seeds and other agricultural inputs were showcased for the benefit of sugarcane growers. Agricultural universities and

organizations related to the sugar industry also displayed their novel technologies and innovative practices. Participants had the opportunity to see a pilot project – demo plant setup at VSI for the production of Green Hydrogen.

With sugar mills going for expansion, the crushing season is becoming shorter, therefore, there is a need to utilize the mechanical and human resources of the sugar mill by diversification. VSI is also exploring the production of Green Hydrogen through water electrolysis using electric power available from co-generation and also in recovery of potash from incineration boiler ash obtained from burning spentwash. VSI is already providing consultancy services to the sugar and allied industry in Maharashtra state as well as across the other major sugarcane and sugar producing states of India. Efforts are on to expand catering of services of VSI to the sugar industry in other countries. Recently, VSI has provided consultancy and advisory services to mills in Tanzania and Philippines.

Shri Nitin Gadkari commended VSI for its outstanding research efforts in tackling the sugar industry's pressing challenges. He emphasized the significance of byproducts alongside sugar production in generating revenue through various co-products. He stressed the importance of enhancing productivity while reducing costs. Additionally, he urged researchers to develop cost-effective technology for producing green hydrogen.

VSI's dedicated scientists, technologists, agriculturalists and staff continue to excel in sugarcane agriculture and the sugar and allied industry, providing valuable services to mills and farmers to meet ever-changing demands. Special thanks to the Director General, Advisor and entire VSI staff for their excellent organization of the 3rd International Conference and Exhibition, making it a tremendous success. The support from the Board of Trustees and Governing Council has been invaluable in efficiently managing the activities of the Institute.

Sharad Pawar
President



VICE-PRESIDENT PERCEIVES



The sugarcane season of 2023-24 was a season of many ups and downs for the sugar industry and the industry lived up to all these challenges. In 2023-24, India produced 417.3 million tonnes of sugarcane from an area of 5.56 million hectares, showing a 6.64% decline in sugarcane production, mainly due to a significant reduction in the area under cultivation, which decreased from 5.91 million hectares in 2022-23. A total of 534 sugar mills in India produced around 32.00 million tonnes of sugar (white value), resulting in 2.33% decrease compared to the previous season. For 2024-25, Indian sugar production is projected at 32.30 million tonnes, considering the diversion for ethanol production. India contributes around 17.5 to 18% of the global sugar production. India's estimated sugar consumption for 2023-24 is around 29 million tonnes, which is an increase of 1.65 million tonnes over the previous season.

The cost of production for sugarcane has been rising steadily due to various factors. Key reasons include higher input cost, labor cost and unpredictable weather patterns, such as droughts or excessive rainfall which affect yield and require additional investments in irrigation or other measures to protect crops, driving up production costs. These rising costs impact small-scale farmers who may struggle to afford the inputs, making it harder for them to maintain profitability. The overall trend shows a significant increase in the cost of producing sugarcane, which may impact the economy of regions heavily dependent on sugarcane farming.

The Institute plays a crucial role in reducing the cost of sugarcane production by developing and promoting low-cost technologies and agro products that enhance input efficiency. The Institute conducts research to

develop cost-effective technologies that can minimize the use of expensive inputs like fertilizers, pesticides and water. These technologies often focus on precision farming, smart irrigation and automation and helping farmers optimize their resources.

The institute provides training and extension services to sugarcane farmers, teaching them how to implement these technologies effectively. This knowledge transfer can have a significant impact on reducing production costs while improving crop yield. The institute also advocates sustainable farming practices, such as intercropping, integrated pest management (IPM), integrated nutrient management (INM) and crop rotation and improvement of soil organic carbon. These practices help reduce the dependence on costly synthetic chemicals and improve soil health over time, leading to reduced long-term costs of sugarcane production.

VSI organized the 3rd International Conference and Exhibition on "Sustainability: Challenges & Opportunities in the Global Sugar Industry" from 12th to 14th January 2024, which provided an opportunity to the entire co-operative as well as the private sugar sector mills, the students of the sugar industry, the employees in the sugar and allied industry as well as to the farmers to understand the new concepts, technologies, practices prevalent in the country and around the globe, which have successfully revolutionized the industry and the farming and led to the financial upliftment of the farmers as well as of the sugar and allied industry. The conference was a success due to relentless efforts of various officials, non-officials and employees of VSI as well as due to the able and visionary leadership of Hon'ble President of VSI.

As the Vice-President of this esteemed institution, I am proud of the significant progress the Institute has made over the past year. I extend my heartfelt congratulations to the scientists, researchers and technologists at VSI for their valuable contributions to the growth and success of the institute.

Dilip Walse-Patil
Vice-President

FROM THE DESK OF DIRECTOR GENERAL



The sugar industry in the state of Maharashtra produced 11.05 million tonnes of white sugar during 2023-24 season by crushing 107.62 million tonnes of sugarcane. Maharashtra State on an average contributes around 34-35% of sugar produced in India and about 6% of world sugar production. Average sugar recovery of the state, calculated after computing the diversion of equivalent of sugar for ethanol production, is recorded at 11.07%, which is considered for the Fair and Remunerative Prices (FRP) payment of sugarcane for 2023-24 season. By mid-October, out of the total FRP payable of ₹ 397.58 billions, sugar mills paid ₹ 397.48 billions of actual FRP payable to the sugarcane growers in Maharashtra State. Dalmia Bharat and Industries Ltd., Sugar Unit Datta Asurle-Porle, District Kolhapur recorded the highest FRP recovery % cane of 13.35% in the state. On the backdrop of Maharashtra state receiving good rainfall in 2024, the sugar production in 2024-25 season is estimated at 11.30 million tonnes by crushing around 111.10 million tonnes of sugarcane.

The average total cost of production in the state of Maharashtra is ₹ 4,192.79/- per quintal of sugar. Therefore, there is a huge scope to reduce the production cost of sugar. With the technical inputs and consultancy from VSI, it is possible to reduce the production cost by increasing the capacity utilization, reducing the thermal and electrical energy consumption as well as chemical cost and maintenance cost. Further, improving the quality of final product and minimizing the total sugar losses by installing latest equipment, implementing advanced technologies and various innovative measures in milling and boiling houses shall also result in reducing the production cost of sugar. Other major steps involve using low pressure vapor for pan boiling, elimination of high pressure

steam in process and implementing profuse vapor bleeding scheme by modifying evaporator configuration.

VSI conducted colour audits and created awareness amongst the process technologists on various parameters to improve sugar colour. It helped immensely to improve average sugar colour to less than 80 IU and thereby to fetch additional premium. Guidelines were provided to the sugar mills to maintain the capacity utilization in the range of 100-110% to reduce the unknown and inversion losses. Awareness was created among the sugar mill personnel on various measures to be taken, from cane harvesting to final sugar production and to produce the superior quality of sugar and reduce the sugar losses.

Implementation of various automation techniques and systems helped to maintain consistency in the process parameters thereby increasing the capacity utilization of equipment, safety of equipment and optimization of manpower. Guidelines were provided to the sugar mills on preventive maintenance activities by following standard operational procedures (SOPs) and maintenance check lists, maintaining of equipment history cards has helped the sugar mills to reduce the repairs and maintenance cost. To avoid operational issues in older Programmable Logic Controller (PLC) systems and system failures, the installation of new Distributed Control System (DCS) by the sugar mills would be beneficial.

It is expected that around 1.25 million tonnes of equivalent of sugar will get diverted for ethanol production in 2024-25 season from Maharashtra state, as against 0.86 million tonnes diverted in 2023-24 by 123 sugar mills. This is inline with the Ethanol Blending Programme (EBP) of the Central Government Policy to achieve the target of blending of 20% of ethanol in fuel by 2025. So far, India has achieved around 14% with approximately 585.5 crore litres of ethanol blended, as of 30th September, 2024.

Various measures have already been taken by the Central Government for increasing the production of ethanol and subsequently, the ethanol blending percentage in fuel. As a part of this endeavor Pradhan Mantri JI-VAN Yojana for finance and investments has been extended for the next five years i.e. upto 2028-29.



The other measures adopted by the Government include -

- expanding the feedstock used for ethanol production,
- reduction in Goods and Services Tax (GST) on ethanol for EBP to 5% so as to make the programme financially viable for producers and consumers,
- ensuring fair compensation for producers by setting favourable procurement price for ethanol,
- modification of the Industries (Development & Regulation) Act, 1951 so as to facilitate the free movement of ethanol across the states and promoting easier blending operations
- providing interest subsidies to augment ethanol production capacity in the country.

These measures shall definitely result in bringing about the desired blending percentage to 20% as envisaged in the original roadmap. India continues to advance in environmental friendly biofuel adoption, reducing dependency on fossil fuels, saving invaluable foreign currency and stimulate market growth.

Over the past decade, Ethanol Blending Programme has resulted in the saving of ₹ 1,060.72 billion in foreign exchange, a reduction of CO₂ emissions by 54.4 million tonnes, and a substitution of 18.1 million tonnes of crude oil. Furthermore, EBP had a considerable economic impact, with Oil Manufacturing Companies disbursing ₹ 1,459 billion to the distillers and ₹ 875.58 billion to the farmers.

Additionally, 10.16 billion litres of ethanol will be required to achieve the target of 20% ethanol blending by 2025 and total demand for ethanol is estimated to be around 13.50 billion litres. To meet this requirement, an ethanol production capacity of about 17.00 billion litres must be established by 2025, assuming the plants operate at 80% efficiency.

Various departments within VSI have been actively collaborating with government organizations to provide guidance and consultancy services.

For the year 2023-24, the Central Pollution Control Board (CPCB), Delhi has tasked VSI with the annual inspection of Grossly Polluting Industries (GPIs) located in the Ganga and Yamuna river basins. As a Third Party Inspection Agency, VSI has inspected 495 industries. The Department of Environmental Sciences, Sugar Engineering and Sugar Technology

have contributed to the formulation of draft of "Comprehensive Charter 2.0 for Effluent Treatment by Sugar Industries in the Ganga Basin" and Department of Alcohol Technology and Biofuels has contributed in drafting the "Charter 2.0 for Zero Liquid Discharge in Molasses-Based Distilleries" for the CPCB. The Department of Environmental Sciences also assisted CPCB in re-categorizing the sugar mills based on environmental performance, considering factors like water usage, quantity and quality of wastewater generation, ETP performance and recycling. The Sugar Technology department is involved in statutory audits like assessment of sugar mills for diversion of feedstock for ethanol production.

The Department of Alcohol Technology and Biofuels is working on a project titled "Process Development of 2G Ethanol Production" funded by GPS Renewables Pvt. Ltd. to the tune of ₹ 138.39 lakh. VSI has also successfully demonstrated the recovery of potash from incineration boiler ash on a pilot scale. The institute has signed seven new Memorandum of Understanding (MoU) with organizations including Pernod Ricard India Pvt. Ltd., Techpert Process Industries, Praj Industries Ltd., Danisco India Pvt. Ltd., De Smet S.A. Engineers & Contributors (DSEC) in Belgium, Nutrition & Health Pvt. Ltd. and GPS Renewables Pvt. Ltd. for advanced research in renewable energy.

Green hydrogen has been the focus of extensive research due to its potential as a clean and environmentally friendly renewable energy source. VSI has actively channelized its effort in research on green hydrogen by installing a green hydrogen demonstration plant, which is capable of producing 2 kg of hydrogen per day, using water electrolysis techniques to generate the hydrogen.

All the four laboratories of VSI which include, the Sugar Technology lab, the Alcohol Technology & Biofuels lab, Department of Environmental Sciences lab and Agricultural Engineering lab were reaccredited by National Accreditation Board for Testing and Calibration Laboratories (NABL) until February 2026.

Efforts have been made to expand operations and collaborations of VSI to overseas mills and organizations. In this regard in 2023-24, consultancy was provided for establishing a liquid biofertilizer production unit at Bagamoyo Sugar Limited in

Tanzania. A technical team from the Sugar Technology department visited VMC Sugar mill in Philippines and successfully conducted the training programme for their officers.

VSI developed CoVSI 18121, a promising sugarcane genotype from a bi-parental cross between Co 86032 and CoT 8201. This genotype, recommended for pre-season and suru planting seasons in Maharashtra, was pre-released following the Research Find Release Committee (RFRC) meeting at Mahatma Phule Krishi Vidyapeeth (MPKV), Rahuri, on 29th April, 2023. CoVSI 18121 is noted for its high sucrose content, thick cane, high yield, excellent ratoonability and non-lodging plant type, representing a significant advancement in sugarcane breeding.

To enhance fertilizer use efficiency and crop productivity, the Soil Science Section developed an integrated nutrient package for calcareous soil and formulated VSI-chelated micronutrient for foliar application. The institute has also initiated a project using drones for foliar application of nutrients to reduce and delay sugarcane flowering. VSI, in collaboration with TIH Foundation, IIT Mumbai, is researching on an Internet of Things (IoT) based real-time sensor system for efficient nutrient management in sugarcane soils of Maharashtra.

The cane loader developed in collaboration with Mr. Mathew Zacharias has been commercialized, easing the cane loading with minimal manpower.

In 2023-24, The Plant Pathology section received AICRP(S) recommendation of foliar application of tebuconazole @ 0.1%, which is effective for management of brown spot disease after the initiation of disease.

Various sugarcane diseases, including whip smut, grassy shoot, brown rust, brown spot, pokkah boeng and yellow leaf have been reported, with an increase in smut disease incidences. VSI emphasizes a three-tier seed nursery program to provide disease and pest-free seeds. Experts from the Agricultural Sciences and Technology division work closely with the sugar mills for the control of smut disease. For managing pokkah boeng disease, VSI recommends three foliar sprays of irradiated chitosan and carbendazim + mancozeb mixture, achieving upto 65% disease control.

The institute is accredited by National Assessment and Accreditation Council (NAAC) with A-Grade for M.Sc. (Wine, Brewing and Alcohol Technology) and M.Sc. (Environmental Sciences) courses. Students of M.Sc. programmes and DIFAT courses were successfully placed in breweries, wineries, distilleries, government and research institutions, academic institutes and consultancy organizations with 100% placement. In 2023-24, VSI trained 1,117 male and 291 female farmers on modern sugarcane agriculture technologies through the 'Oos Sheti Dnyanyag' and 'Oos Sheti Dnyanlaxmi' programs, respectively. Additionally, 697 farmers and officials from Government and NGOs were trained under sponsored and tailor-made programmes.

The 3rd International Conference and Exhibition was held successfully from 12th to 14th January, 2024. The conference was held on the theme of "Sustainability : Challenges & Opportunities in the Global Sugar Industry" and inaugurated by Shri Nitin Gadkari, Honorable Union Minister of Road Transport and Highways, Government of India presided over by Shri Sharad Pawar, Honorable President of VSI. 2800 delegates from 28 countries attended the conference. A total of 65 eminent speakers from 21 countries including Indian experts presented their scientific research papers, their insights and their views in 13 sessions on agricultural, financial and technical topics.

I am grateful to the President, the Vice President and Trustees and members of the Governing Council for their generous support and guidance. I thank scientists, engineers, technologists, staff and students of VSI for their untiring efforts and dedication towards the research, extension, consultancy and training. I am pleased to present this 48th issue of Annual Report of 2023-24 to all our distinguished readers with assurance that the institute will continue its path towards achieving the progress of the sugarcane growers, sugar and allied industries.

Sambhaji Kadupatil
Director General



ABOUT VSI

Vasantdada Sugar Institute (VSI) formerly known as Deccan Sugar Institute, is an autonomous body which is a Registered Society, registered under the Societies Registration Act, 1860 and under the Bombay Public Trusts Act, 1950. It has been set up to serve the Sugar Industry in India in general and Maharashtra in particular. Established by cane grower members of the cooperative sugar factories in Maharashtra with an active and generous support of Government of Maharashtra, it is the only organization of its kind in the world.

Genesis

When it comes to the real crunch, what sets any scientific organization apart are cutting edge Research & Development, the ability to deliver to make a difference and the skill to mould opinions and to act as a catalyst of the industry. These are the qualities that are inherent in VSI.

From empowering cane growers to explore new frontiers of Science and Technology, from moulding public opinion to being a platform for all sections of the sugar industry, no organization other than VSI has done so much for the industry.

The cane growers of Maharashtra who were woefully short on education but tall on imagination and impulse established this Institute. Their vision led to the development of an organization that was to symbolise a unique partnership between sugar industry, the scientific community and the cane growers. During the span of 1950-1970, there was a rapid expansion of the Sugar Industry on the Deccan Plateau. In order to meet its ever increasing scientific and technical needs, the cooperative sugar industry in Maharashtra took the initiative and under the able and visionary leadership of the Late Dr. Vasantdada Patil, cane grower members of cooperative sugar factories forged an alliance and through a historic decision established this organization in 1975. The Institute adopted "*Sanshodhanen Samvrudhi*" meaning prosperity through research as its motto and began work in areas relevant to sugar industry through three channels namely, R&D, Extension services and Human Resource Development (HRD).

As a natural consequence, the Institute stays ahead and keeps abreast of the latest developments in the field of Science and Technology, remains relevant to the evolving needs of the sugar industry and also stays focused to the needs of sugarcane growers.

Objective

The objective of VSI is to achieve an all encompassing progress of the Indian Sugar Industry through Human Resource Development, Extension services and Research & Development.

Location

VSI is located at Manjari village on the eastern outskirts of Pune city on the bank of river Mula Mutha. It is 12 km and 17 km away from Pune railway station and Pune airport respectively. Pune itself is located about 1500 km southwest of Delhi and 160 km southeast of Mumbai. Organization Membership of VSI is given to sugar mills and their ancillary units from Maharashtra and other States. At the end of the reporting year the Institute's membership stood at 159.

The Institute is managed by a Board of Trustees comprising 11 members headed by its President. To supervise and monitor the functioning of the Institute, a Governing Council (GC) comprising 41 members has been formed which includes Board of Trustees, elected members and nominated members. Three smaller groups or committees of the GC members assist the GC in its overall functioning.

The Director General is the executive head of the organisation implementing the decisions of the management and assisted by various divisional heads. The Institute performs multifarious functions through inter-disciplinary groups within a divisional structure. The divisions are:

1. Agricultural Sciences and Technology
2. Sugar Technology
3. Sugar Engineering
4. Alcohol Technology & Biofuels
5. Environmental Sciences
6. Electronics and Computer
7. Instrumentation
8. Education

These are supported by administration, finance, accounts, civil engineering, statistics, art & photography and library.

A sound infrastructure set-up can alone deliver excellence in the quality of work and therefore, no stone has been left unturned in ensuring that the expression world class in the best sense of the term is particularly apt to the infrastructure of VSI.

VSI has created an impressive infrastructure which includes

- An administrative building housing a well equipped auditorium with a seating capacity of a 250 contemporary, seminar hall with a seating capacity of 100, a well equipped boardroom and an amphi theatre.
- Two R&D blocks (92,000 sq.ft.) housing state-of-the-art laboratories of agriculture, sugar technology, alcohol technology, environmental sciences, electronics & computer and instrumentation
- Laboratories of molecular biology and genetic engineering (10,000 sq.ft.) with a greenhouse (2,000 sq.ft.).
- Contemporary sugarcane tissue culture laboratory the biggest of its kind in the country with greenhouses (16,000 sq.ft.).
- A bio-fertilizer plant (8,750 sq.ft.) with a capacity of 500 t/annum and vermi-sheds (5,800 sq.ft.).
- Pilot winery and Nano-brewery (5,400 sq.ft.) for hands on training to students and contract research.
- An engineering workshop (15,000 sq.ft.).
- Students' laboratories (69,000 sq.ft.).
- A well equipped library housing over 20,000 books and other reference materials.
- A well equipped computer centre with a LAN of 250 nodes that caters to the needs of users.
- Students' hostel and guest-house (55,000 sq.ft.) and a new hostel (37,000 sq.ft.) with excellent facilities.
- Residential accommodation (41,000 sq.ft.).
- Naigaon farm: Office (6,470 sq.ft.), quarters (5,791 sq.ft.), bio-fertilizer lab. (1,038 sq.ft.), multinutrient shed (1,438 sq.ft.) and shed nets (10,330 sq.ft.).

- Vasantdada farm: office (380 sq.ft.) and godown (348 sq.ft.).
- Lonarwadi farm: Office, godown, implement shed, VIP suits (4,769 sq.ft.), labour quarters (2,808 sq.ft.), threshing yard (6,366 sq.ft.), old farm pond (30,294 sq.ft.), green house (6,198 sq.ft.), farm pond (1,35,009 sq.ft.), pump house (264 sq.ft.), panel & pump room, filter room for drip system (965 sq.ft.).
- Amboli farm: Office and residence (2,474 sq.ft.), building, guest house and canteen (10,544 sq.ft.), hybridization chamber (2,329 sq.ft.), electrical panel room (344 sq.ft.), watchman quarter (240 sq.ft.), toilet block (148 sq.ft.), entrance gate (272 sq.ft.), store sheds (705 sq.ft.).
- Patharwala farm: Farm pond (1,30,000 sq.ft.).
- Nagpur farm: 63.8 ha
- An all weather helipad.

VSI is the only organization in Asia and probably in the world to have such a formidable infrastructure exclusively for sugarcane and sugar research in the cooperative sector.

Key Core Competencies

A. Research and Development

VSI's R&D programme aims at assessing and meeting the current as well as future needs of the sugar industry in context of prevailing socio-economic conditions of the country. In ultimate analysis, it provides qualitative and quantitative data for more efficient use in the sugar industry of men, machines and materials all of which cost money. VSI's current interests include, inter alia, development of promising sugarcane varieties through biotechnology, water conserving irrigation systems, eco-friendly methods of crop production and crop protection, reduction in sugar losses in mills, co-generation, energy audit, pollution abatement, application of modern and sophisticated techniques in farms and in mills, appropriate software for sugar mill and by-product units, development of byproducts, development of bio-fertilizers and vermicom post for improving soil fertility and productivity.



B. Technical Services

- Technical consultancy in the fields of crop improvement, crop production and crop protection.
- Technical consultancy and project reports for erection of new plants, modernization, expansion of the existing units of sugar, co-generation & distilleries, up-gradation of effluent treatment plants (ETPs).
- Technical audit & performance evaluation of mills.
- Technical consultancy for increase in capacity utilization, reduction of total sugar losses, improvement of sugar quality and overall technical efficiency, conservation of steam, power & water, zero liquid discharge, optimization of process chemical dosage, logic for automation.
- Environmental clearance, compliance of clearances & consents and environmental audits.
- Analysis of sugar samples, sugarhouse products, molasses, alcohol & liquors, denaturants, process chemicals, soil, water, air, effluents, noise, wine, beer, microbial analysis of soil, liquid bio-fertilizers, bio-control samples, compost and vermicompost. Testing of drip irrigation materials.
- Provision for pure yeast cultures to distilleries and micro-breweries.
- Production of quality seed material, tissue culture plantlets, liquid bio-fertilizers, vermi-compost, micronutrient fertilizer and microbial cultures.
- Multiplication of bio-control agents.
- Development of VSISugarERP, a quality software solution for sugar and allied industry.
- Calibration of process & laboratory instruments and consultancy for implementation of appropriate instrumentation & automation systems in sugar, cogeneration & distillery units.
- Sugar Development Fund (SDF) appraisal and monitoring

C. Human Resource Development

VSI offers a multitude of academic programmes both short-term and long-term designed to upgrade and enhance the skills of the sugar industry personnel.

These include post-graduate diploma and certificate courses in sugar technology, alcohol and fermentation technology, sugar engineering, environmental sciences and instrumentation. Several short-term training programmes are offered during off-season, which aim at improving the competence of managers, technologists, workers and farmers. Special need based programmes are conducted at the request of clients. Over 6800 professionals from India and abroad have so far been bestowed with VSI diplomas and certificates.

VSI is recognized as Scientific and Industrial Research Organization (SIRO) by the Ministry of Science and Technology, Government of India. In addition, VSI is also recognized as a research centre for Ph.D. studies by reputed Universities from the State viz. Savitribai Phule Pune University, Pune and Shivaji University, Kolhapur. The Institute also conducts two master's degree courses affiliated to the Savitribai Phule Pune University viz. M.Sc. (Environmental Sciences) and M.Sc. (Wine, Brewing & Alcohol Technology). These courses were accredited by NAAC (National Assessment and Accreditation Council) awarded with "A" grade to the institute in the year 2022-23.

Achievements

With 48 years of presence in the field, VSI has come out with a large number of research papers, completed several projects, developed diagnostic and control systems, brought about process optimization and obtained patents. Notable among its innovations are automatic drip irrigation system for cane, vermicompost from municipal and farm waste, bio-fertilizers, Vasant Urja biological control of pests and diseases, elite cane varieties through tissue culture, microprocessor-based pH control, online estimation of brix using nucleonic density meter, automatic estimation of moisture in bagasse, juice flow stabilization, development of SugarERP Software, a complete and quality software solution for sugar and allied industries and other software, alcometer, chemical fastest kits, reduction in sugar losses, improvement in the quality of sugar during processing, improvement in capacity utilization and optimization of energy consumption in factories and development of by-products like oxalic acid and sucrose ester.

Realities

- VSI is concentrating exclusively on R & D of sugarcane agriculture and sugar industry.
- Government of India recognizes VSI as a centre of excellence in sugar research.
- VSI is recognized as a centre for undertaking research leading to Ph.D. degrees of various universities.
- Accreditation of four VSI laboratories by the National Accreditation Board for Testing and Calibrating Laboratories (NABL) as also their recognition by the Bureau of Indian Standards has bestowed upon the Institute a statutory acknowledgment of its technical competence.
- Department of Biotechnology & National Institute of Plant Genomic Research, Govt. of India has recognized VSI as Accredited Test Laboratory (ATL) under National Certification System for Tissue Culture raised Plants (NCS-TCP) for virus indexing and genetic fidelity testing.

- Maharashtra Energy Development Agency (MEDA) recognizes VSI as Energy Auditing Centre for co-generation projects.
- Export-Import Bank of India empaneled VSI for preparation of detailed project report (DPR) in the sector of industrial projects, renewable energy and water.
- Many sugar mills, distilleries and government bodies actively seek personnel from VSI.
- VSI is also being noticed worldwide with many high profile visits by scientists, technologists and other eminent people from all over the world.

An existence after 1975, VSI stands tall today. It has moved from strength to strength over the years and has emerged stronger tackling many challenges. In this way, the Institute has withstood the test of time and continues to operate on principles on which it was established. VSI has, thus, carved a niche for itself in the world when it comes to sugarcane research. VSI is now poised to be an ever important player in the Indian Sugar Industry in years to come.



1st Alumni Meet of VSI



BOARD OF TRUSTEES

1)	Mr. Sharad G. Pawar Former Minister for Agriculture Food Processing Industries, Govt. of India	Chairman
2)	Mr. Dilip Walse-Patil Minister for Co-operation, Govt. of Maharashtra	Member
3)	Mr. Vijaysinh S. Mohite-Patil Former Deputy Chief Minister, Govt. of Maharashtra	Member
4)	Mr. Ajit Pawar Deputy Chief Minister, Govt. of Maharashtra	Member
5)	Mr. Jayant R. Patil Former Minister for Water Resources and Command Area Development, Govt. of Maharashtra	Member
6)	Mr. Balasaheb B. Thorat Former Minister for Revenue, Govt. of Maharashtra	Member
7)	Dr. Indrajit Y. Mohite Former Chairman, Yashwantrao Mohite Krishna SSK Ltd.	Member
8)	Mr. Jaiprakash Dandegaonkar Former President, National Federation of Co-operative Sugar Factories Ltd. (NFCSF), New Delhi	Member
9)	Mr. Vishal Patil Chairman, Vasantdada Shetkari SSK Ltd.	Member
10)	Mr. B. B. Thombare Chairman, Natural Sugar and Allied Industries Ltd.	Member
11)	Mr. Narendra Ghule Patil Chairman, Loknete Marutrao Ghule Patil Dnyaneshwar SSK Ltd.	Member (From 10/3/2024)





GOVERNING COUNCIL

1	Mr. Sharad G. Pawar Former Minister for Agriculture Food Processing Industries, Govt. of India	President
2	Mr. Dilip Walse-Patil Former Minister for Co-operation, Govt. of Maharashtra	Vice President
3	Mr. Vijaysinh S. Mohite-Patil Former Deputy Chief Minister, Govt. of Maharashtra	BOT & Member
4	Mr. Ajit Pawar Deputy Chief Minister, Govt. of Maharashtra	BOT & Member
5	Mr. Jayant R. Patil Former Minister for Water Resources and Command Area Development Govt. of Maharashtra	BOT & Member
6	Mr. Balasaheb B. Thorat Former Minister for Revenue, Govt. of Maharashtra	BOT & Member
7	Dr. Indrajit Y. Mohite Former Chairman, Yashwantrao Mohite Krishna SSK Ltd.	BOT & Member
8	Mr. Jaiprakash Dandegaonkar Former President, National Federation of Co-operative Sugar Factories Ltd., New Delhi	BOT & Member
9	Mr. Vishal Patil Chairman, Vasantdada Shetkari SSK Ltd.	BOT & Member
10	Mr. B. B. Thombare Chairman, Natural Sugar and Allied Industries Ltd.	BOT & Member
11	Mr. Narendra Ghule Patil Chairman, Loknete Marutrao Ghule Patil Dnyaneshwar SSK Ltd.	BOT & Member (From 10/3/2024)
12	Dr. Vishvajit Kadam Former State Minister for Co-operation, Agri.& Food Supply, Govt. of Maharashtra and Chairman, Dr. Patngraokadam Sonhira SSK Ltd.	Member
13	Mr. Diliprao D. Deshmukh Chairman, Vikasratna Vilasraoji Deshmukh Manjara Shetkari SSK Ltd.	Member
14	Mr. Rajesh Ankushrao Tope Former Minister for Health, Govt. of Maharashtra and Chairman, Karmayogi Ankushrao Tope Samarth SSK Ltd.	Member
15	Mr. Prakash K. Awade Chairman, Kallapanna Awade Jawahar Shetkari SSK Ltd.	Member
16	Mr. Satej D. Patil Former State Minister for Home, Govt. of Maharashtra and Chairman, Dr. D.Y. Patil SSK Ltd.	Member
17	Mr. Arvindrao J. Gore Chairman, Dr. Babasheb Ambedkar SSK Ltd.	Member

Cont...



GOVERNING COUNCIL (Contd.)

18	Mr. Ganpatrao S. Tidke Chairman, Bhaurao Chavan SSK Ltd.	Member
19	Mr. Shirishkumar Naik Chairman, Adiwasi SSK Ltd.	Member
20	Mr. Babanrao V. Shinde Chairman, Shri Vitthalrao Shinde SSK Ltd.	Member
21	Mr. Balsaheb Alias Shamrao P. Patil Former Minister for Co-operation, MS and Chairman, Sahyadri SSK Ltd.	Member
22	Mr. Shriram Shete Chairman, Kadwa SSK Ltd.	Member
23	Mr. Harshwardhan S. Patil President, NFCSF, New Delhi and Chairman, Indreshwar Sugar Mills Ltd.	Member
24	Mr. Ashok Pawar Chairman, Raosahebdada Pawar Ghodganga SSK Ltd.	Member
25	Mr. Rohit R. Pawar CEO, Baramati Agro Ltd.	Member
26	Mr. Vivek Bipin Kolhe Chairman, Sahakar Maharshi Karmveer Shankarrao Kolhe SSK Ltd.	Member (From 10.3.2024)
27	Minister for Co-operation , Govt. of Maharashtra	Member
28	President , National Federation of Co-operative Sugar Factories Ltd., New Delhi	Member
29	President , Maharashtra Rajya Sahakari Sakhar Karkhana Sangh Ltd., Mumbai	Member
30	President , National Heavy Engineering Co-operative Ltd.	Member
31	President , Deccan Sugar Technologists Association	Member
32	Vice-Chancellor , Savitribai Phule Pune University	Member
33	Vice President , Maharashtra Council of Agriculture Education & Research	Member
34	Joint Secretary (Sugar) , Ministry of Food and Civil Supplies, Govt. of India	Member
35	Director , National Chemical Laboratory, Pune	Member
36	Commissioner of Sugar , Maharashtra State	Member
37	Commissioner of Agriculture , Maharashtra State	Member
38	Director , National Sugar Institute, Kanpur	Member
39	Director , Technical Education, Maharashtra State	Member
40	Managing Director , Maharashtra Rajya Sahakari Sakhar Karkhana Sangh Ltd.	Member
41	Director General , Vasantdada Sugar Institute, Pune	Member





COMMITTEES

BUILDING & PURCHASE COMMITTEE		
1	Mr. Dilip Walse-Patil	Chairman
2	Mr. Vijaysing Mohite-Patil	Member
3	Mr. Ajit Pawar	Member
4	Mr. Jaiprakash Dandegaonkar	Member
5	Mr. Vishal Patil	Member
6	Mr. Rajesh Tope	Member
7	Mr. Prakash Awade	Member
8	Mr. Shirishkumar Naik	Member
9	Mr. Narendra Ghule Patil	Member
10	Mr. Arvindrao Gore	Member
11	Mr. Shriram Shete	Member
12	Director General, VSI	Member
13	Advisor, VSI	Member-Invitee
SELECTION COMMITTEE		
1	Mr. Balasaheb Alias Shamrao Patil	Chairman
2	Mr. Jayant Patil	Member
3	Mr. Balasaheb Thorat	Member
4	Mr. Rajesh Tope	Member
5	Mr. Satej Patil	Member
6	Director General, VSI	Member
7	Advisor, VSI	Member-Invitee
TECHNICAL COMMITTEE-TECHNICAL		
1	Mr. Jayant Patil	Chairman
2	Mr. Vijaysing Mohite-Patil	Member
3	Mr. Balasaheb Thorat	Member
4	Mr. Balasaheb Alias Shamrao Patil	Member
5	Mr. Diliprao Deshmukh	Member
6	Mr. Rajesh Tope	Member
7	Dr. Vishvajit Kadam	Member
8	Dr. Indrajit Mohite	Member
9	Mr. Vishal Patil	Member
10	Mr. B.B.Thombare	Member
11	Mr. Ashok Pawar	Member
12	Mr. Rohit Pawar	Member
13	Director General, VSI	Member
14	Advisor, VSI	Member-Invitee
TECHNICAL COMMITTEE - AGRICULTURE		
1	Dr. Indrajit Mohite	Chairman
2	Mr. B.B.Thombare	Member
3	Mr. Ganpatrao Tidke	Member
4	Mr. Shriram Shete	Member
5	Mr. Arvindrao Gore	Member
6	Mr. Harshvardhan Patil	Member
7	Mr. Babanrao Shinde	Member
8	Director General, VSI	Member
9	Advisor, VSI	Member-Invitee
INVESTMENT COMMITTEE		
1	Mr. Ajit Pawar	Chairman
2	Dr. Indrajit Mohite	Member
3	Mr. Vishal Patil	Member
4	Director General, VSI	Member
5	Chief Accountant, VSI	Member
6	Advisor, VSI	Member-Invitee



3rd International Conference & Exhibition 'Sustainability: Challenges & Opportunities in Global Sugar Industry' January 12-14, 2024

The 3rd International Conference and Exhibition 2024 on the theme of “Sustainability: Challenges & Opportunities in the Global Sugar Industry” was organized from January 12-14, 2024. The 3rd International Conference & Exhibition was inaugurated on January 12, 2024 by the Chief Guest of this conference, Shri Nitin Gadkari, Honorable Union Minister of Road Transport and Highways, Government of India. The conference was presided over by Shri Sharad Pawar, Honorable President of Vasantdada Sugar Institute. The Inaugural session was attended by more than 2800 participants including delegates, exhibitor and students.

Shri Sharad Pawar, in his welcome speech mentioned that the 3rd International Conference has been organized to discuss and deliberate all related issues ranging from agriculture to sugar processing and development of by-product such as alcohol, bio-fuels, ethanol and co-generation. The sugar sector faces various challenges of biotic and abiotic nature along with infrastructural issues. These issues can be addressed by evolving a farm management system that employs the latest tools like artificial intelligent, sensor technology, GIS, robotics etc. He emphasized that the precision agriculture can best be brought about by introducing this latest technology so as to create the farm of the future. He stressed upon the sugar production is affected by climate change, resulting in reducing the yield of sugarcane and also the sugar mills need to find out a way to utilize resources by diversifying portfolio to production of ethanol, Compressed BioGas (CBG), Hydrogen, aviation fuel, green Hydrogen and other products etc. Shri Nitin Gadkari in his inaugural address applauded the research contribution of Vasantdada Sugar Institute which is remarkable and historical and still continuously engaged in research. He pointed out that alongwith production of sugar, the byproducts are equally important. Increasing the productivity with less expenditure cost will be important. He also insisted that scientists regarding R&D on technology for green hydrogen production at low cost.

On this occasion, Mr. Guilherme Nastari, Director, DATAGRO, São Paulo, Brazil was the Key Note speaker and touched upon the topic “Roadmap for sugar independence, food security & energy transition - based on sustainable bioenergy production”. He spoke about the future of mobility with reduced carbon emissions and the ways of reducing consumption of energy used in transport is electrification but there are still large opportunities to reduce energy consumption with the optimization of internal combustion engines (ICEs) as well as the introduction of intermediate solutions such as hybrid vehicles. Because it has a high anti-knocking index (AKI), ethanol is an efficient blend component to gasoline. Also, ethanol has a high hydrogen content, is easy to produce, store and distribute and does not require investments in new distribution systems. Mobility based on high-density low-carbon footprint liquid fuels is a very economical and accessible solution to many countries. Production of biofuels is replicable, scalable and can provide a rapid response for implementation of strategies aimed at contributing to reach scenarios of limited global warming impact. The expansion of biofuels can provide a sensible route of diversification to many sugar economies, bringing more stability to sugar prices, reducing energy dependence, and providing longevity and sustainability for the use of traditional fuels in complement with biofuels.

In this conference, a total of 63 scientific speeches of eminent speakers across the world were organized in 13 sessions on agricultural as well as technical topics including the Plenary Session as follows;

Plenary session: 'Worldwide Sugar and Co-Product Industry'

Technical Sessions I: 'Green Technology-Circular Bioeconomy'

Global Market Session: 'Sugar Mills - Financial Discipline and Management'

Technical Sessions II: 'Modern Developments in Processing and Engineering'

Technical Session III: 'Challenges & Opportunities in Bioethanol'

Technical Sessions IV: 'Environmental Sustainability in the Sugar and Allied Industry'

Agricultural Sessions I: 'Perspectives in Sugarcane Improvement Industry'

Agricultural Sessions II: 'Soil Sustainability: Challenges and Priorities'

Agricultural Sessions III: 'Micro Irrigation and Mechanization'

Agricultural Session IV: 'Sustainable Sugar Beet Industry – Emerging Challenges'

Agricultural Sessions V: 'Microbes and Potential Bioagents in Sustainable Sugarcane Production'

Agricultural Sessions VI: 'Pest in Sugarcane: Facts & Management Approach'

Agricultural Sessions VII: 'Sustainable Sugarcane Production and Management Practices'

Technology Provider Session-I: The following companies presented their company profile and their products; Saisidha Sugar Equipments & Engg. Co., Ulka Industries, Praj Industries, Regreen Excel EPC India, Priviledge Bicksons Boilers, Sitson India, Indiana Sucro Tech (Pune), Moj Engineering Systems, Shreeji Process Engineering, Chem Process Systems, Global Enviro Engineering, Ncon Turbo Tech, and CG Power & Industrial Solutions.

Technology Provider Session II: In this session, following OEM/machinery manufactures delivered their new technology, design concept, and new equipment related to sugar and its byproducts. Universal Forces Industries, Mill Gears, Forbes Marshall, Shree Kurmdas Industries, Aryan Boilers, Thyssenkrupp Industries India, KSB, Bajaj Power Equipments, Fives Cail KCP, Spray Engineering Devices and Yaskawa India

Technology Provider Session III: The following OEM/machinery manufacturers delivered their new technology, design concept, and new equipment related to sugar and its byproducts; Interis India, CRI Pumps, Suviron Equipments, Thermax, SS Engineers, Siemens, Uttam Energy, Raj Process Equipments and Systems, MAN Energy Solutions, Aquatech Systems, Schneider Electric, KBK Chem Engineering, Paharpur Cooling Towers and Clean Earth Energy Solutions India.

Technology Provider Session (Agriculture): In this session invited speakers presented their presentation on 'Nano Fertilizers for Sustainable Agriculture' and 'Impact of Sub-Surface Drainage System on Soil Properties and Crop Yield'

Poster Proceeding: The total 127 abstracts received in different themes among that 84 abstracts were received from other institute/organization and 43 abstracts were received from different sections of VSI.

Exhibition and Live Crop Demonstrations: The 3rd International Conference was a massive event in the sense that exhibition of international standard with total 276 sponsors from the country and abroad has participated in this exhibition. In this exhibition, the new technologies developed by sugar factories, refineries, manufacturers of machinery for projects, agricultural implements related to farmers, seeds, agricultural inputs were displayed. Agricultural universities, organizations related to the Sugar Industry displayed their new technologies in this conference. State-of-the-art machinery such as harvesters, planters and drones was also displayed. The participants had the opportunity to see a pilot project for the production of green hydrogen displayed by VSI.

A unique aspect of this event was the live crop demonstrations of sugarcane through 96 live demo plots in the field. The live crop demo exhibited various advanced technologies and agricultural practices covering major sugarcane varieties from India, three-tier seed nursery programme, planting of tissue cultured plantlets for seed nursery programme, intercropping in sugarcane, modern methods of sugarcane cultivation technology, integrated nutrient management for sugarcane, use of biofertilizers, various irrigation systems, integrated disease and pest management etc. Similarly, demonstrations have been organized on remediation of salt affected soil and scientific method of soil sampling.

New aspect of this conference was the farmer gallery where interviews on the success stories of the sugarcane growers that have received awards and also of the award winning Cane Development Officers, Agricultural Officers, Managing Directors and Chairman of the award winning sugar mills were broadcasted.



TECHNICAL PERFORMANCE OF SUGAR MILLS IN MAHARASHTRA: SEASON 2023-24 (October 2023 to September 2024)

Sugar production scenario

The global sugar output (raw value) in 2023-24 season was 181.26 million tonnes as compared to the previous season's production of 177.75 million tonnes. The sugar production has increased by 3.51 million tonnes (1.97%) over the previous season 2022-23. The stock to consumption ratio of sugar remained at 54.36%. Current indications are that global sugar production in the forthcoming 2024-25 season will decline and estimated at 179.29 million tonnes with consumption expected to be at 181 million tonnes. The main reason for a decline in sugar output for 2024-25 is due to anticipated drop in sugar production of Brazil by 3.58 million tonnes.

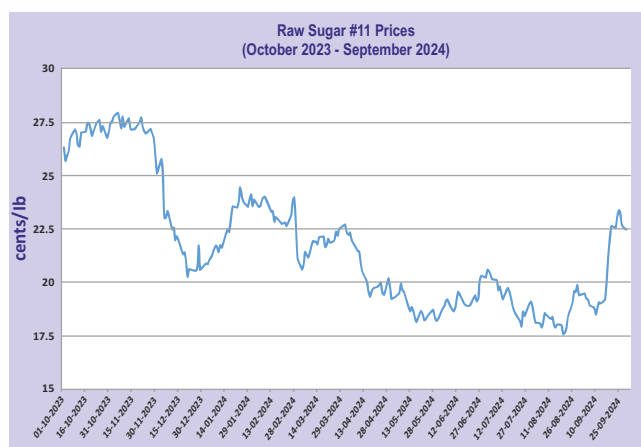

During the season 2023-24, monthly average raw sugar prices decreased from US\$593.04 per tonne (October 2023) to \$401.68 (August 2024). The trend graph of sugar prices showed a decreasing trend after the first week of November 2023 to Mid-August 2024 with lowest price of US \$498.90 recorded on 20th August, 2024. The white sugar prices also showed similar trend. The white sugar prices decreased from US\$723.47 per tonne (October 2023) to US\$513.90 (August 2024).

The Indian sugar industry is having a huge opening stock of sugar of 9.79 million tonnes for the season 2023-24 and the production was 32.13 million tonnes (white value) which was 1.52% less than the last

season (32.62 million tonnes). This drop in production can be attributed to the decrease in sugar production of major states viz. Tamil Nadu (↓26.25%), Haryana (↓20.27%), Gujarat (↓8.91%), Karnataka (↓6.90%) and Punjab (↓6.06%). It is expected that net sugar production will decline by around 2 million tonnes due to more diversion of B-heavy molasses and sugarcane juice for ethanol production. The country will have a carry forward sugar stock of around 9.05 million tonnes.

Maharashtra produced 11.05 million tonnes (white value) of sugar during 2023-24 with increase of 4.84% as compared to the previous season's sugar production 10.54 million tonnes (2022-23). During the season 2023-24, 123 sugar mills in the state diverted B-Heavy molasses/cane/syrup for ethanol production by sacrificing 0.86 million tonnes of sugar. In the forthcoming season 2024-25, it is expected that the state will likely to produce 11.30 million tonnes of sugar by crushing 111.10 million tonnes of sugarcane and around 1.25 million tonnes of equivalent sugar diverted for ethanol production. There will be likely reduction in production of sugarcane crop also due to heavy and uneven rainfall, which affected decrease in area under sugarcane and cane yield in some parts of the state.

Sugarcane and sugar production in the major sugar producing states of India

The production of sugarcane and sugar in the country has always shown wide fluctuations. These fluctuations are due to variations in the area under sugarcane, climatic conditions, water availability during the crop growth period and most importantly, remunerative and timely payment of cane price to sugarcane growers. In addition, it depends upon a number of factors such as quality seed material, incidence of diseases and pests, irrigation facilities, availability of fertilizers, ratoon management and the Government's policy on sugarcane pricing. The production of sugarcane and sugar in the major states of the country for last five seasons as shown in the following graph.

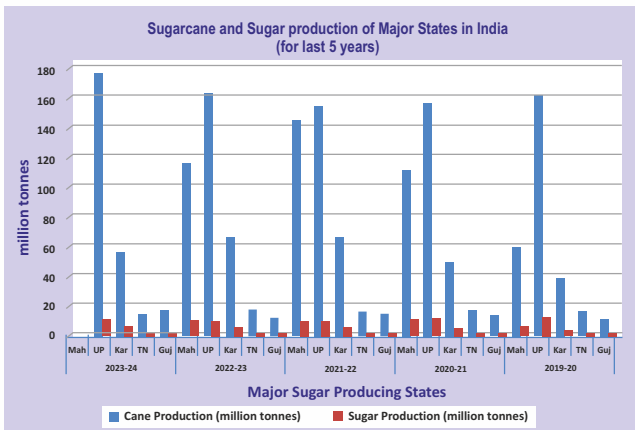

Technical performance of sugar mills in Maharashtra

The technical performance of sugar mills in the state for last five seasons is presented in Table 1. During the current season 2023-24, the state produced 11.05 million tonnes of sugar (net production) by crushing 107.62 million tonnes of cane, 4.84% more over the previous season's net sugar production of 10.54 million tonnes. Average recovery of the state for sugar bagged is recorded at 10.27% with an increase of 0.27 units

over the previous. The sugar diverted for ethanol production is less than previous season because the Central Government has restricted use of feedstock viz. B-Heavy molasses, syrup and cane juice for ethanol production to 170 lakh tonnes to make available more sugar. The average sugar recovery sacrificed due to diversion of different feedstocks is 0.79 units. Hence, the average final sugar recovery is 11.07% that is considered for Fair and Remunerative Price (FRP) for sugarcane.

The contribution of the state in country's sugar production is 34.40% in 2023-24. There are 250 sugar mills in the state with total installed sugarcane crushing capacity of 0.993 million tonnes per day. Out of these 150 sugar mills, 134 sugar mills are co-operative sugar mills and 116 are private. The sugarcane crushing capacities of these sugar mills vary from 500 to 16000 tonnes crushing per day (TCD). In 2023-24, total 208 sugar mills were in operation. The zone-wise technical performance of sugar mills comparative for crushing seasons 2022-23 and 2023-24 is given in Table 2.

Table-1: Technical performance of sugar mills in Maharashtra (from 2019-20 to 2023-24)

Particulars	Season				
	2019-20	2020-21	2021-22	2022-23	2023-24
No. of installed sugar mills	244	246	246	249	250
No. of sugar mills in operation	147	191	200	211	208
No. of sugar mills not in operation	96	55	46	38	42
Installed capacity ('000 TCD)	802.35	826.70	870.65	931.50	993.00
No. of sugar mills diverted sugar for ethanol production	23	88	106	122	123
Gross days	110	142	174	122	130
Sugarcane crushed (million tonnes)	55.06	101.46	132.23	105.39	107.62
Sugar bagged (million tonnes)	6.20	10.64	13.72	10.54	11.05
Sugar diverted for ethanol production (million tonnes)	0.12	0.69	1.21	1.35	0.86
Net Sugar production incl. diversion (Million tonnes)	6.32	11.33	14.93	11.89	11.91
Sugar recovery % cane (actual sugar bagging)	11.26	10.48	10.38	10.00	10.27
Final FRP sugar recovery % cane	11.48	11.17	11.29	11.28	11.07
Capacity utilization %	89.66	95.32	91.75	93.50	84.55
Lost hours % to available hours.	9.84	9.86	11.07	10.54	13.63
Pol % cane	13.42	13.12	13.22	13.21	13.13
Share of Maharashtra in country's sugar production (%)	22.68	34.46	38.32	31.97	34.40

Table-2: Zone-wise technical performance of sugar mills in Maharashtra

Characteristics	2022-23				2023-24			
	South	Central	North-East	State	South	Central	North-East	State
No. of installed sugar mills	58	91	100	249	59	91	100	250
Installed capacity ('000 TCD)	274.50	383.40	273.60	931.50	299.85	405.05	288.10	993.00
No. of sugar mills not in operation	6	9	23	38	2	14	26	42
No. of sugar mills in operation	52	82	77	211	57	77	74	208
No. of sugar mills diverted sugar for ethanol production	27	53	41	121	26	53	44	123
Gross days	129	123	121	124	127	134	129	130
Sugarcane crushed (million tonnes)	33.01	44.56	27.82	105.35	34.73	44.56	28.33	107.62
Sugar bagged (million tonnes)	3.68	4.22	2.64	10.54	3.91	4.44	2.70	11.05
Sugar diverted for ethanol production (Million tonnes)	0.38	0.61	0.35	1.34	0.23	0.36	0.27	0.86
Net Sugar production incl. diversion (Million tonnes)	4.06	4.83	2.99	11.88	4.14	4.80	2.97	11.91
Sugar recovery % cane (actual sugar bagged)	11.15	9.47	9.49	10.00	11.27	9.95	9.54	10.27
Sugar recovery % cane (final FRP recovery)	12.30	10.85	10.76	11.28	11.94	10.75	10.52	11.07
Capacity utilization %	91.33	93.71	94.10	93.50	85.74	82.88	85.71	84.55
Lost hours % to available hours	6.49	9.72	14.36	10.54	9.39	12.63	17.88	13.63
Pol % cane	14.14	12.78	12.78	13.21	13.96	12.77	12.67	13.13
Fibre % cane	13.21	12.89	13.33	13.13	13.16	12.88	13.31	13.11
Sugar lost % cane	3.01	3.36	3.30	3.24	2.71	2.84	3.12	2.87
R.M.E. (Mittal)	95.71	94.62	95.01	95.03	95.64	95.09	94.86	95.16
Added water % fibre	216.74	204.27	202.58	206.71	216.63	207.91	204.61	209.11
R.B.H.R. (GunduRao)	83.53	80.87	82.04	81.94	89.74	88.73	88.91	89.07
R.O.E. (Mittal- GunduRao)	79.94	76.46	77.94	77.85	85.81	84.39	84.34	84.76
Molasses % cane	4.42	5.04	5.27	4.91	4.74	4.98	5.23	4.96

Salient features of the state for crushing season 2023-24

- The sugar production of Maharashtra State was 11.05 million tonnes in 2023-24 by crushing 107.62 million tonnes of cane, an increase by 4.84% than that of its previous season (10.54 million tonnes).
- Baramati Agro Ltd. in Pune district and Vitthalrao Shinde SSK Ltd., Unit-1 in Solapur district achieved the maximum cane crushing of 2.155 and 1.892 million tonnes, respectively.

- Baramati Agro Ltd., Pune and Jarandeshwar Sugar Pvt. Ltd., Satara produced the maximum sugar 0.245 and 0.209 million tonnes respectively.
- The average sugar recovery was 10.27% (actual sugar bagged recovery), which is increased by 0.27 units as compared to the previous season. This may be due to less diversion of B-Heavy molasses/cane juice/syrup for ethanol production by 123 sugar mills.



- From Kolhapur district, Kumbhi Kasari SSK Ltd. recorded the highest actual sugar bagged recovery 12.83% in the state, followed by 12.70% recovery of Deshbhakta Ratnappanna Kumbhar Panchganga SSK Ltd.
 - Units of Dalmia Bharat Sugar and Industries Limited namely, Shri Datta, Asurle-Porle Unit in Kolhapur district recorded the highest final FRP sugar recovery 13.35% in the state and followed by its Ninaidevi Unit (13.08%) in Sangli district.
 - Total 86 sugar mills achieved sugar recovery % cane of 11 and above.
 - The average pol% cane decrease to 13.13% from the previous season's 13.21%. Total 30 sugar mills reported pol % cane of 14 and above.
 - The average crushing capacity utilization was 84.55%, decreased by 9.06 units over its previous season.
 - The average RME (Mittal) and average RBHR (G'rao) was 95.16% and 89.07% respectively. The average RBHR is below the standard norm of 90.00% due to the diversion of different feed stocks by 123 sugar mills for ethanol production.
- Government policies on the sugar industry**
- The Government has not allowed sugar exports for the current 2023-24 year (October- September), to make more sugar available for domestic supply and control retail prices. The Director General of Foreign Trade (DGFT) has allocated 8606 metric tonnes raw value (MTRV) for export of raw cane sugar to USA from India under Tariff Rate Quota (TRQ) scheme from October 1, 2024 to September 30, 2025. The DGFT has allocated 5841 MT for export of sugar to EU from India under TRQ scheme from October 1, 2024 to September 30, 2025.
 - The Union Cabinet approved extension of scheme of sugar subsidy for Antyodaya Anna Yojna (AAY) families distributed through Public Distribution Scheme (PDS) for two more years i.e. 31 March 2026. Under the Scheme, the Central Government gives subsidy of Rs.18.50 per kg per month of sugar to AAY families of participating States. The scheme is expected to benefit about 1.89 crores AAY families of the country.
 - The Central Government has fixed a target of 10% blending of fuel ethanol with petrol by 2021-22 and 20% by 2025-26. To achieve the 20% blending target, approximately 1016 crore liters of ethanol will be required and 1350 crore liters of ethanol will be required by considering other uses. By 2025, it is estimated that an ethanol production capacity of around 1700 crore liters will be required assuming 80% capacity utilization. India's current ethanol production capacity is reached to 1648 crore liters. There is a need to augment production capacity with sugar mills as well as necessary infrastructure and storage with Oil Marketing Companies (OMC). In ethanol supply year 2023-24, 585.2 crore liter ethanol was supplied to Oil marketing companies and achieved 13.8% ethanol blending up to end of September 2024. During season 2023-24, around 2.00 million MT of equivalent sugar is diverted for ethanol production.
 - During ESY 2023-24 (Nov-Oct), ex-mill the price of ethanol from C heavy molasses route is ₹ 49.41 per litre, B-heavy molasses ₹ 60.73 per litre, sugarcane juice/sugar / sugar syrup ₹ 65.61 per litre. The prices of ethanol produced from food grains such as Damaged Food Grains (DFG), maize & FCI rice are decided by Oil Marketing Companies (OMCs). The prices of Damaged Food Grains (DFG) is ₹ 64.00 per litre, rice from FCI ₹ 58.50 per litre and maize ₹ 66.07 per litre. OMCs have announced an intensive of ₹ 6.87 per litre on ethanol produced from C-heavy molasses and ₹ 5.79 per litre on ethanol produced from maize.
 - The Central Government under the Pradhan Mantri JI-VAN Yojana provides financial support to 2G bio-ethanol projects with a total financial outlay of ₹ 1969.50 crore for period from 2018-19 to 2023-24 for 12 commercial projects and 10 demonstration projects. This will boost setting up of more ethanol distilleries in the country.
 - The Union Minister for Petroleum & Natural Gas has launched ETHANOL100, a revolutionary fuel at Indian Oil Retail Outlet at New Delhi on March 15, 2024. The customers avail ETHANOL100 at 183 retail outlets from five states viz. Maharashtra, Karnataka, Uttar Pradesh, New Delhi and Tamil Nadu.

- There was restriction (capped at 1.7 MMT) on use of sugarcane juice/B-heavy molasses for manufacture of ethanol and Extra Neutral Alcohol (ENA) as per order No. 3(2)/2023-SP dated 15.12.2023. Subsequently, the Government has allowed sugar mills to use additional 6.7 lakh MT of B-heavy molasses for ethanol production.
- The government has imposed 50 per cent duty on exports of molasses, a by-product of sugarcane used as raw material for alcohol production, with effect from January 18, 2024.
- The Central Government has facilitated mutually agreed price of Potassium Derived from Molasses (PDM) at ₹ 4,263/MT for sale by sugar mills to fertilizer companies for the current year. In addition, PDM Manufacturers can also claim subsidy at ₹ 345/MT at present rates under Nutrients Based Subsidy Scheme (NBS) of Department of Fertilizers. A potassium rich fertilizer derived from ash in molasses based distilleries is a by-product burning of spent wash in Incineration Boiler (IB) generating Ash to achieve Zero Liquid Discharge (ZLD). The potash-rich ash can be processed to produce PDM having 14.5% potash content and can be used by farmers in field as an alternative to MOP (Muriate of Potash with 60% potash content).
- Government of India announced a Green Hydrogen Policy on 17th February 2022. Hydrogen has proved to be better fuel than petrol and diesel and is destined to be the fuel of the future. Hydrogen based vehicles shows three times better mileage than diesel engines. Hydrogen is a cleaner fuel which upon combustion produces water. Maharashtra is the first state in the country implementing green hydrogen policy. On 4th January 2023, the Union Cabinet, GoI approved the National Green Hydrogen Mission with an outlay of ₹ 19,744 crore from FY 2023-24 to FY 2029-30. The overarching objective of the Mission is to make India a global hub for production, usage and export of Green Hydrogen and its derivatives. By 2030, India's Green Hydrogen production capacity is likely to reach 5 MMT per annum, contributing to reduction in dependence on import of fossil fuels. It is expected to reduce a cumulative ₹ 1 lakh crore worth of fossil fuel imports by 2030 and nearly 50 million metric ton per annum of CO₂ emissions are expected to be prevented through production and use of the targeted quantum of Green Hydrogen. The Government of Maharashtra has taken decision in cabinet meeting and approved the budget of ₹ 8,562 crore for implementation of green hydrogen projects in the state.
- Government announces mandatory blending of Compressed Bio-Gas (CBG) in CNG (Transport) and PNG (Domestic) segments of CGD sector. CBG Blending Obligation (CBO) will encourage investment of around ₹ 37500 crores and facilitate establishment of 750 CBG projects by 2028-29. The CBO program will help in saving foreign Exchange, promoting circular economy and achieving net zero emission. CBO shall be kept as 1%, 3% and 4% of total CNG/PNG consumption for FY 2025-26, 2026- 27 and 2027-28 respectively. From 2028-29 onwards CBO will be 5%.
- Another important announcement was made for promoting biofuels in the country. Production of sustainable aviation fuel (SAF) is necessary to de-carbonize of the aviation sector in line with India commitment for achieving net zero emission by 2070. On 25th November 2023, SAF blending targets were set in 2027 and 2028 as 1% and 2% respectively initially for International flights. The country will require around 14 and 28 crores litres of SAF/annum.
- The Central Government has fixed the Fair and Remunerative Price (FRP) of sugarcane payable by sugar mills for sugar season 2024-25 (October-September) as under:
 - i) FRP of sugarcane for 2024-25 sugar season at ₹ 340/- per quintal for basic sugar recovery rate of 10.25%.
 - ii) A premium of ₹ 3.32 per quintal for every 0.1% increase above 10.25% recovery.
 - iii) Reduction in FRP proportionately by ₹ 3.32 per quintal for every 0.1% point decrease in recovery, in respect of those sugar mills whose recovery is below 10.25% but above 9.5%. However, for sugar mills having recovery 9.5% or below, the FRP is fixed at ₹ 315.10 per quintal.

SERVICES



HUMAN RESOURCE DEVELOPMENT

The development of human resource along with quality infrastructure is essential for any organization/industry that would like to be dynamic and growth oriented. HRD is vital to overall productivity and efficiency of the strong work force in any organization in general. The rapidly growing high technology boosts the requirements of sugar manufacturing industries and byproducts industries to produce multiple quantity of output, with quality product to meet the growing demand. To adopt the use of such new technology, the human resource should be upgraded continuously through training and skill development. The institute has designed training modules by experts exclusively to impart training to inculcate the value of modern technology to every person to utilize their maximum talent and modern skill to avoid wastage and any kind loss during the process of production.

The popular and reputed Universities from Maharashtra State like Savitribai Phule Pune University, Pune. Mahatma Phule Agriculture University, Rahuri and Shivaji University Kolhapur, and other University have honored our courses and VSI also recognized as a Research Centre for Ph.D. Degree. The institute also conducts post-graduate course, (M.Sc.) in Environmental sciences and Wine Brewing and Alcohol Technology affiliated to the Savitribai Phule Pune University, Pune. These courses are accredited by NAAC (National Assessment and Accreditation Council) awarded with “A” grade to the institute in the year 2022-23. The institute is planning to introduce more professional courses to upgrade the educational qualification and proficiency of students employed/ sponsored by reputed sugar industries and also concentrates more to develop close and cordial association and develop human relationship with all sugar and allied industries. The institute identify the specific requirements and organize new courses to cater to their needs. The dedicated service rendered by this institute in this field has been highly appreciated by highly prominent sugar and by product industries in India and aboard those who sponsor candidates to institute to enhance Dynamism and Professionalism.

The institute has established a state of the art technical lab and offers abundant opportunity to the trainees to update knowledge, practice to expand the

production. This institute has been successfully producing excellent human resources and extends the best opportunity to organize campus interview every year. The management (HRM) from leading prominent sugar institutes visit to institute and select right candidates for right job. Almost all the students are fortunate to get bright avenue of job opportunity. The institute organizes various short term courses to cater the needs of the industries.

The courses conducted by the Institute are;

- Regular courses (PG Diploma, Masters Degree, Certificate Courses)
- Short term training programmers (For Sugar & Allied Industry employees)
- Summer training programmes
- Customized courses for foreign students
- Training to farmers (*Dnyanyag* and *Dnyanlaxmi*)
- Sponsor training programs for Agriculture officers

Regular courses

The regular courses comprised of PG Diploma, Master Degree, Certificate duration from 6 months to 2 and ½ years. The list of regular courses there duration and number of students enrolled in each courses is given in the table 1 and the year of commencement courses and the total student enrolled since inception are in given table 1 and 2.

Short term training programme (STTP)

Keeping the knowledge of the workforce updated is a crucial part of Human Resource Development. VSI also offers STTP for employees of sugar mills to enhance working knowledge vision to adopt new technology and also guide the industries to reform normal function of sugar and allied industries. The training courses largely guides and assist the industries in any factors. The workforce in the sugar industry comprises of not only the person working in the mill but also the farmers in the cultivation in the sugar mill. VSI regularly conducts short term and refresher courses for sugarcane farmers and personnel working in the difference section in the sugar mill and distilleries. The details of the courses are given in table 3, 4 and 5.



Table 1: Courses offered and the students enrolled for 2023-24

Course title	Duration	Number of students		
	(Years)	Maharashtra	Other States	Total
(I) POST GRADUATE DIPLOMA (AVSI)				
Sugar Technology	2 ½	15	31	46
Industrial Fermentation & Alcohol Technology	1 ½	73	77	150
Sugar Engineering	1 ½	06	03	09
Sugar Instrumentation Technology	1 ½	-	-	-
(II) MASTERS DEGREE (affiliated to Savitribai Phule Pune University, Pune)				
M.Sc. (Environmental Sciences)	2	22	02	24
M.Sc. (Wine, Brewing and Alcohol Technology)	2	22	02	24
(II) CERTIFICATE COURSES				
Sugar Engineering	2 off season	10	05	15
Sugar Manufacturing	2 off season	79	06	85
Sugar Boiling	1 off season	18	39	57
	Total	245	165	410

Table 2: Courses and number of students enrolled since inception

Programme	Year of commencement	No. of Students
Sugar Technology	1981	1740
Sugar Engineering Certificate	1981	572
Sugarcane Development	1982	132
Sugar Instrumentation Technology	1984	358
Sugar Engineering PG Diploma (AVSI)	1984	469
Industrial Fermentation & Alcohol Technology	1985	2712
Microprocessor & Computer Controlled System for sugar & allied industry	1986	52
Environmental Sciences	1992	639
Pulp and Paper Technology	1992	82
Sugar Boiling Certificate	1992	1609
Sugar Industrial Management	1992	12
Industrial Safety	1992	04
Juice Supervision Certificate	2000	155
Sugar Manufacturing Certificate	2005	782
Wine, Brewing & Alcohol Technology	2011	289
ETP Operation & Maintenance	2013	14
	Total	9621

Table 3: Short term training programmes enrolled mill workers/technicians

Name of STTP	No. of Participants
Juice Clarification	58
Pan Boiling	80
DFPD	80
Boiler Attendant	30
Mill Foreman	38
Fermentation & Distillery	50
Techniques Instrumentation	6
Pollution Contro	115
ETP Operation	7
Repairs and Maintenance	30
Special Analysis	08
Analysis of Water/Waste water & Solid Waste	04
Total	416

The following STTPs are conducted by the Institute are:

- Juice Clarification & Evaporation
- Pan Boiling & Centrifugals
- Boiler Attendant
- Mill Foreman
- Fermentation & Distillation techniques in distillery
- Techniques in Analytical Instrumentation
- Repairs & Maintenance of Sugar Mill Instruments
- Pollution Control and Environment Management in Sugar Mill
- ETP Operation
- Special Analysis in Laboratory
- Analysis of Water/Waste water & Solid waste

Table 4: Short term training programmes (Farmer's training)

Duration	Topic	No. of Participants	Details of Participants
June 27 -30, 2023	Oos Sheti Dnyanyag	230	Men farmers from regional areas of sugar mills in Maharashtra
July 04 - 07, 2023	Oos Sheti Dnyanyag	213	
July 10 - 13, 2023	Oos Sheti Dnyanyag	199	
July 18 - 21, 2023	Oos Sheti Dnyanlaxmi	152	Women farmers from regional areas of mills in Maharashtra
Nov. 21- 24, 2023	Oos Sheti Dnyanlaxmi	138	
Nov. 2 - 01, Dec. 2023	Oos Sheti Dnyanyag	136	Men farmers from regional areas of sugar mills in Maharashtra
Dec 05 - 08, 2023	Oos Sheti Dnyanyag	146	
Dec 12 - 15, 2023	Oos Sheti Dnyanyag	90	
Dec 18 - 22, 2023	Oos Sheti Dnyanyag	103	
Total		1407	

Table 5: Sponsored training programs

Duration	Topic	No. of Participants	Details of Participants
May. 30 - Jun. 01, 2023	Modern Technologies in Sugarcane Agriculture	Solidaridad Regional Expertise Center, New Delhi	50
June 06-07, 2023	Modern Technologies in Sugarcane Agriculture	Solidaridad Regional Expertise Center, New Delhi	54
Jun. 12-14, 2023	Advanced Technologies in Sugarcane Agriculture	Solidaridad Regional Expertise Center, New Delhi	50
Jun. 15-17, 2023	Modern Technologies in Sugarcane Agriculture	Solidaridad Regional Expertise Center, New Delhi	50
Jun. 19-21, 2023	Modern Technologies in Sugarcane Agriculture	Solidaridad Regional Expertise Center, New Delhi	50
Jul. 14-16, 2023	Modern Technologies in Sugarcane Agriculture	ATMA, Sambhajinagar and Sangli Purna SSK Ltd., Hingoli	186



Table 5: Sponsored training programs (Contd.)

Duration	Topic	No. of Participants	Details of Participants
Sep. 15-16, 2023	Modern Technologies in Sugarcane Agriculture	National Food Security Mission, DJDA, Sambhajinagr and Latur Division	35
Dec. 28-30, 2023	Modern Technologies in Sugarcane Agriculture	ATMA, Beed, Parbhani & Kolhapur	165
Feb. 11-16, 2024	Advanced Technologies in Sugarcane Agriculture	Lal Bahadur Shastri Ganna Kisan Sanstha, Lucknow, UP	22
Feb. 21-23, 2024	Advanced Technologies in Sugarcane Agriculture	ATMA, Beed and ICAR Tribal Sub Plan	35
Total			6

Summer training programmes

All laboratories at VSI are provided with the latest equipments and state of the art facilities. Many students are interested to work in these laboratories with the scientists of the Institute to add value to their educational qualifications. The institute provides vacation training to students from various universities across the country in its laboratories. Some students also work under the guidance of the scientists of the institute for their dissertation. The excellent infrastructure and laboratory facilities at VSI are well known. The table 6 shows university wise students enrolled & students completed summer training at VSI.

Table 6: University-wise students enrolled for summer training at VSI

Name of the University	Students
Savitribai Phule Pune university Pune	21
Mahatma Phule Krishi Vidyapeeth, Rahuri	18
Yashvantrao Chavan Institute of Science, Satara	2
Bharati Vidyapeeth, Pune	4
Fergusson College, Pune	3
Dr. D.Y. Patil Biotechnology and Bioinformatics Institute, Tathawade, Pune	2
MIT Art, Design & Technology University, Pune	4
Amity University, Bhatan, Panvel, Mumbai	1
Loknete Dr. Balasaheb Vikhe Patil, Pravara Rural Education Society, College of Agriculture Biotechnology, Dist. A.Nagar	2
Department of Biotechnology Manipal Institute of Technology, Manipal	1
Dr. Babasaheb Sawant Kokan Krsihi Vidyapeeth, Dapoli	9
Vilasrao Deshmukh College, Latur	1
Total	68

Customized courses for foreign students:

The Institute contributes exemplary efforts to render immense service, guidance and genuine assistance to the sugar industries of Abroad. Special attention is given to organize special courses of different durations to meet needs, to enable higher production and to achieve desired target.

Countries like Bhutan, Ethiopia, Uganda, Nepal Kenya, Tanzania, Sudan, Vietnam and Fiji sponsor students to Institute to undergo short term and long term training courses. The number of foreign students passed out from the Institute since inception is given in the table 7.

Table 7: Number of foreign students enrolled till date

Country	Students
Sudan	69
Sri Lanka	20
Fiji	16
Uganda	09
Nepal	08
Kenya	38
Ethiopia	07
Tanzania	03
Bhutan	02
Total	172

Placement

The placement cell of the Institute constantly interacts with the sugar, machinery manufacturers, distillery and allied industries in and abroad to identify opportunity of job openings for the needy, admirable and deserving students. The Institute helps students to find the right job and companies to find the right

employee for company. The Institute also provides training to the students to increase employability by arranging sessions for aptitude and training on communication skills. Therefore, the Institute has introduced a subject of communication skills to help in effective writing, dialogue with customers and employees. The Institute has been successful in maintaining a high placement statistic over the years. The various organizations/ industries are given in table 8.

Alumni meet

1st Alumni meet was convened at Vasantdada Sugar Institute, Manjari (Bk), Pune on January 11, 2024. On this occasion, Mr. Sharad Pawar Hon. President of VSI was the Chief Guest and Mr. Sambhaji Kadupatil, DG, Mr. Shivajirao Deshmukh, Advisor, and Mr. DB Ghule,

Principal/ Registrar were present. Around 253 alumni from the year 1984 to 2023 batches of Sugar Technology, Sugar Engineering, Instrumentation, Environment Sciences and Wine, Brewing & Alcohol Technology students were present for this event.

National Assessment and Accreditation Council (NAAC)

The institute conducts post-graduate course, (M.Sc.) in Environmental sciences, Wine Brewing & Alcohol Technology and also recognized research centre for the Ph.D. program. These courses are affiliated to the Savitribai Phule Pune University, Pune. As per the University norms the Institute has been accredited by NAAC (National Assessment and Accreditation Council) awarded with “A” grade to the institute in the year 2022-23 for 5 years.

Table 8: Organizations for the placements

Maharashtra State	Other State
Allied Blenders and Distillers	Bangalore Brew Works, Karnataka
Bombay Breweries Ltd.	Big Pither Brewery, Karnataka
Bombay Duck Brewing Company	Bajaj Hindustan Ltd., Uttar Pradesh
Brewcrafts Microbrewing Pvt. Ltd.	Copper Sugar, Gujrat
Brentaag	Chamundeshari Sugar, Karnataka
Brentaag, Masters Brewing Company, Bengaluru	Carlsberg India P. Ltd., (All over India)
Cerveza brewery and restaurant IIP	DSCL Sugar, Uttar Pradesh
Effingut Brewerkz	Ganesh Khand Udyog, Gujrat
Event Horizon Beverages P. Ltd.	Gems Sugar, Karnataka
Fratelli Wines P. Ltd.	Globus Spirits, New Delhi
Jay Mahesh	Goa Brewing Company, Goa
Kimaya Brewing Company	John Distilleries, Karnataka
Moet Hennessy India	Novozynes, Karnataka
Poineer Distilleries	Sabmiller Breweries Pvt. Ltd., (All over India)
Radico NV Distilleries	Snj Breweries India Ltd., Andhra Pradesh
Ravalgaon Sugars	Som Group of companies, Madhya Pradesh
Smokie (Deccan Brewing Company)	Renuka Sugars, Karnataka
South Seas Distilleries	The Biere Club Brewpub, Karnataka
Pernod Ricard India Pvt Ltd.	Ugar Sugars, (Unit-2), Karnataka
Tilaknagar Industires Ltd.	United Spirits Ltd., Karnataka
Carlsberg India Ltd. Chh. Sambhajinagar	Uttam Spirits, Uttar Pradesh
Yavasura Brews IIP	Vijaynagar Sugar, Karnataka
United Breweries Pvt. Ltd.	Karnataka
Wave Industries Pvt. Ltd.	Uttar Pradesh
Mawana Sugars Pvt Ltd.Gurgaon,	Haryana
Catalyst Biotechnologies Pvt. Ltd.,	Uttar Pradesh
Adllers Bio-energy Pvt Ltd.	Maharashtra
Shri. Renuka Sugars Ltd, Karnataka	Adlers Bioenergy Ltd, Oosmanabad
Khemani Distilleries Pvt. Ltd., Daman	SPY Agro India Ltd.,
United spirits Ltd., Rajasthan, Baramati, Nanded	India Glycol Ltd, Kashipur, Uttarakhand
Radico Khaitan Ltd., Rampur Uttar Pradesh	EID parry India Ltd., Tamilnadu
Sula Vinyards, Nashik	



LIBRARY

The Institute's library is a knowledge resource centre for sugar and allied industry. The library manages the both archival print resources and contemporary digital resources. It has subscribed to various print and e-resources to fulfill the information need of users. Library has a collection of 19,433 documents including books, proceedings research reports, Ph.D. thesis, IS standards and back volumes of journals. Access to various online journals & proceedings was made available to library users. Library is utilized by scientists, faculties, students and industry personnel for the academic, administrative and research work. The library functioning is fully automated with iSLIM library automation software. Readers can easily access the library OPAC by LAN and search the library collection by title, author, and subject keywords. Library allows open access system for its users.

Membership

The library has offered its membership to the scientists, faculties, technologists, sugarcane growers, students of various AVSI courses, research scholars, sugar mill personnel, sugar industry specialist and special group users. The membership of the library is open to all sugar industry specialists from all over India.

Services

During the year library provided following services and facilities to users.

- **Reference service:** Reference service is an important service offered by the library. During the year, total 375 reference queries were raised readers and answered by library reference desk.
- **Periodical service:** The library has subscription of 36 print and online periodicals consisting of 24 national and 09 international periodicals.
- **Library OPAC:** Library using iSLIM library management software for library automation and provided OPAC service through <http://192.168.1.3/iOPAC/Home/> link by LAN to all users. User can search the resources by Author, Title, Subject and Key words etc.

- **User orientations:** The library conducted 16 orientation programmes for new users and visitors.
- **Email alert service:** Library member gets an email alert service at the time of issue/return/renewal and overdue of books and journals.
- **QR code service:** Library started QR code service to user to access online previous year question papers through Google Drive.
- **Database service:** Library has made available more than 10 web databases and some of them are available as open access on internet. During the year library updated his on digital repository through new addition of e-resources.

Collection development

Total 39 new books were added to the library collection. Thus, the total book collection now is 19,433. During the year library subscribed total 36 periodicals along with 350 open access e-journals and 10 news papers collection fulfill the current information needs of the users. The library has made notable progress in developing library collection related to sugar and allied industries, environmental science, wine technology, statistics and proceedings were added to the collection.

Circulation section

During the year library started automated circulation system in the library and managed all the circulation activity through computer system like members' registration, issue, return, renewal, and auto overdue reminder sent by mail. 410 new student of the institute were enrolled as library users and 223 staff members data added in the circulation system. In the year, the library offers barcode-enabled library smart cards to registered library members. Smart cards help track user accounts and save time using library services. The library stopped the manual circulation system and started computerized circulation. In the year around 780 students from AVSI course used the library service in both semesters. As per the circulation statistic report total 3900 loan transactions were done in the year.

Library automation and digitization

During the year library added wine technology books in catalogue module of iSLIM. The system is integrated with barcodes and smart cards to accurate & faster issue /return work. IT infrastructure is upgraded with latest version.

Organization membership

The membership of National and international associations related to sugar and allied industries has been renewed. This includes:

International

- Australian society of sugarcane Technologists (ASSCT), Australia
- International Consortium for Sugarcane Biotechnology (ICSB), Thibodaux, USA
- International Society of Sugarcane Technologists (ISSCT), Mauritius
- Sugar Industry Technologists Inc. (SIT), New York
- World Association of Beet and Cane Growers (WABCG), France

National

- Biotech Consortium India Ltd. (BCIL), New Delhi
- Indian Association of Special Libraries & Information centers (IASLIC) Kolkata
- Maratha Chamber of Commerce Industries and Agriculture (MCCIA), Pune

- Maharashtra Economic Development Corporation (MEDC), Mumbai
- The Sugar Technologists Association of India (STAI), New Delhi
- Society for Sugarcane Research and Development (SSRD), Coimbatore

The information received from these organizations in the form of directory, yearbooks, newsletter, journals, proceedings and souvenirs was circulated among the technical persons and scientists for reference and study. New additions to the library were communicated to the users through VSI Bulletin, a web journal of the institute. The scientists and technocrats from industry and organizations are the main beneficiaries of this activity.

VSI publications

Important publications of VSI viz. *Oos Sheti Dnyanyag* (Marathi and Hindi), Technical and Financial performance of Sugar Mills in Maharashtra, Technical performance of member distilleries in Maharashtra, Surplus power co-generation in sugar industry, Maintenance book of sugar engineers, 'Sakhar Abhiyantriki : Yantra aani Tantra' book and new addition of "VSI-The Vision & the Accomplishment" are made available to the users at a discounted price. All publications have ISBN from RRRNA (Raja Rammohun Roy National Agency).



Visit of Peer Committee of National Assessment and Accreditation Council (NAAC) in its first accreditation cycle at VSI

AGRICULTURAL SCIENCES AND TECHNOLOGY





AGRICULTURE SCIENCES AND TECHNOLOGY

The Agricultural Sciences and Technology department is a group of divisions put together are: Crop Improvement, Crop production and Crop protection. R&D activities relevant to the organizations goals, technology transfer through various extension activities and human resources development of the persons working in sugarcane agriculture under sugar mills are some of the salient features of this department.

Development of improved sugarcane varieties suitable to different agro-climatic regions in the state through hybridization, selection of desired mutant clones and advanced tools of molecular biology & genetic engineering is the focus of the division. A promising high sugared, high yielding, drought tolerant with higher fiber sugarcane variety VSI 12121 (VSI 08005) has been released for commercial cultivation in Peninsular zone of India. VSI developed another promising sugarcane genotype CoVSI 18121 from the bi-parental cross of Co 86032 and CoT 8201. This new genotype has been pre-released and this variety is recommended for the Preseason and *Suru* planting seasons in Maharashtra State

Developing the best agronomical practices for enhancing sugarcane productivity and enhancing the soil fertility is taken care by Crop production division. Vasant Urja, a bio-stimulator that can be mixed with other water soluble fertilizers, insecticide and bio-fertilizers will help to reduce the operational cost and enhance the crop production. Programme on seed production of sugarbeet genotypes for tropical region in collaboration with USDA-ARS, USA is undertaken. Agronomic evaluation of different legume crops developed by BARC, Mumbai under sugarcane based cropping system was undertaken for their mass multiplication. GPS and GIS techniques have been developed for preparing the soil fertility maps and to suggest soil fertility and nutrient management practices. Application of VSI's liquid bio-fertilizers & liquid bio-control agents to increase sugarcane yield, controlling different diseases & pests and maintaining soil health and plant health in integrated nutrient, disease & pest management. Application of VSI's liquid bio-pesticide for controlling white grub as a bio-control measure is getting popular. Developed sugarcane loader to minimize the human drudgery in

cane loading operation and another two models of tractor drawn sugar beet planter i.e. for sole sugar beet crop sowing and sowing of sugar beet as inter crop. The sugarcane planter developed by VSI has been granted the patent by Controller General of patent for 20 years. The crop protection division looks after the R&D activities related to pests and disease incidence and plant protection measures.

RESEARCH AND DEVELOPMENT

CROP IMPROVEMENT

The division comprises of three sections viz., Sugarcane Breeding, Tissue Culture and Molecular Biology & Genetic Engineering.

SUGARCANE BREEDING

Sugarcane varieties are the essence of the sugar industry. The yield improvement directly impacts the economic viability of sugarcane farming by increasing the amount of sugar produced per hectare. By selecting & breeding high-yielding varieties, farmers can achieve greater productivity without expanding their cultivation areas, optimizing land use and resources. Simultaneously, enhancing sugar content in sugarcane is equally important as it directly correlates with the quality of the final sugar product and its market value. Improving yield and sugar content in sugarcane varieties is a critical objective in sugarcane breeding programs.

To fulfill these objectives, following long term research programs are being undertaken.

- Breeding of new sugarcane varieties combining high yield and sucrose content, having resistance to biotic and abiotic factors adapted to the different agro climatic regions of the Maharashtra state.
- All India Coordinated Research Project on Sugarcane [AICRP(S)] to develop and identify location specific varieties for peninsular zone.
- Collection of sugarcane germplasm, expansion, evaluation, characterization and utilization in breeding program.
- Screening of genotypes for drought and salinity tolerance.
- Screening of newly developed genotypes for incidence to diseases/pests.
- Production of nucleus seed of commercial varieties.



Breeding of new sugarcane varieties

Release of varieties

CoVSI 18121 is a mid-late maturing sugarcane genotype developed from the bi-parental cross of Co86032 x CoT 8201 was pre-released and recommended for Preseason and *Suru* planting seasons in Maharashtra State in the Research Finding Release Committee (RFRC) meeting held on 29th April, 2023 at MPKV, Rahuri. It has good characteristics like high sucrose content, thick cane, high cane yield with better ratoonability and non-lodging plant type.



Fig.1: Field view of variety CoVSI 18121 and canes

Elite selections from pre-final varietal trial (PFVT)

Total sixteen elite clones from 2019 and 2020 batches were evaluated in PFVT trial. Out of total sixteen clones, seven clones viz., CoVSI 64-4

(Co11004 GC) from 2019 and VSI 276-12 (Co 0328 PC), VSI 270-81 (Co 0227 PC), CoVSI 7-13 (CoM 9220 x CoT 8201), VSI 270-141 (Co 0227 PC), VSI 124-66 (Co 11020 x Co 775), VSI 238-46 (VSI 121-50 x Co 89003) from 2020 Batch were found significantly superior over the standards Co86032 and CoC 671 for cane and sugar yield (table 1).

Elite selections from final varietal trial (FVT)

Out of six clones tested in FVT-I (2017 Batch & 2018 batch) at SMS Kolhe SSK, Kopergaon, only one clone from 2018 batch viz., VSI 106-8 (97 A 44 X Co 86249) (Cane yield-162.21 t/ha and CCS-22.38 t/ha) was found significantly superior over the standard Co 86032 (Cane yield-129.79 t/ha and CCS-18.20 t/ha) for cane yield and sugar yield and it was significantly superior for cane yield only to standard MS 10001 (Cane yield-130.72 t/ha and CCS-19.20 t/ha). None of the genotype were found superior over standard VSI 08005 (Cane yield-138.79 t/ha and CCS-20.52 t/ha) for cane and sugar yield.

Another set of eight promising genotypes were planted at Patharwala farm from 2018 batch, only one genotype VSI 109-8 (VSI 27-1 x Co 86011) (Cane yield-154.68 t/ha and CCS-22.42 t/ha) was

Table 1: Performance of Sugarcane Clones in Pre Final Varietal Trial (2019 and 2020 Batch)

Clone	Sugar Yield (t/ha)	Cane Yield (t/ha)	Sucrose (%)	CCS (%)
CoVSI 64 -4	23.60	163.75	20.18	14.43
VSI 276 -12	23.34	161.08	20.32	14.48
VSI 270 -81	21.37	156.15	19.24	13.70
CoVSI 7 -13	23.09	155.91	20.88	14.81
VSI 270 -141	20.99	148.50	19.88	14.15
VSI 124-66	21.57	147.90	20.68	14.60
VSI 238 -46	19.19	145.13	18.98	13.23
Co 86032 (Std.)	18.04	128.56	19.72	14.05
CoC 671 (Std.)	17.93	120.53	20.78	14.88
CoM 0265 (Std.)	21.29	155.87	19.22	13.70
VSI 08005 (Std.)	19.62	137.41	20.01	14.29
VSI 434 (Std.)	17.27	116.29	20.86	14.87
MS 10001 (Std.)	19.06	129.91	20.56	14.67
PDN 15012 (Std.)	19.62	138.45	19.86	14.18
CD at 5%	2.78	21.15	1.26	0.94
CV %	6.44	6.93	3.04	3.19

found significantly superior for cane yield over the standards Co 86032 (Cane yield-132.56 t/ha and CCS- 18.99 t/ha) and CoC 671 (Cane yield-126.62 t/ha and CCS- 18.62 t/ha) and numerically superior over the standards VSI 08005 (Cane yield-139.76 t/ha and CCS-20.53 t/ha) for cane and sugar yield. None of the genotype was found significantly superior than the standards CoM 0265 (Cane yield-159.05 t/ha and CCS-21.10 t/ha) and VSI 08005 for cane and sugar yield however, VSI 109-8 was found numerically superior than the standards CoM 0265, VSI 08005, Co 86032 and CoC 671 for sugar yield.

State level multi-location trial (SAU's)

State Level Multi-location trials were conducted at VSI, Pune; CSRS, Padegaon and RS & JRS, Kolhapur in collaboration with MPKV, Rahuri during the reporting year. Total six trials viz., MLT-II Plant-*Adsali*, MLT- I Plant- Ratoon-*Adsali*, MLT-II Plant-Preseason, MLT-I Plant-Ratoon-Preseason, MLT-II Plant-*Suru* and MLT-I Plant Ratoon-*Suru* were conducted at VSI, Pune. Total nine genotypes viz., CoM 18005, CoM 18008, PDN 15012, CoM 18016, CoM 18022, CoM 18025, VSI 82-1, VSI 125-2 (VSI 21121) and CoVSI 12-2 were evaluated along with standards viz., Co 86032, CoM 0265, VSI 08005, CoC 671, MS 10001, Co 09004 and VSI 434 (table 2). The results of MLT's conducted in *Adsali*, Preseason and *Suru* seasons are as under;

MLT-II Plant- *Adsali*: Out of total nine genotypes studied, four genotypes viz., CoVSI 12-2, VSI 125-2, VSI 82-1 and PDN 15012 were found significantly superior over the standards Co 86032 and CoC 671 for cane and sugar yield. Whereas, genotype CoM 18025 was found significantly superior over the standard Co 86032 only for cane yield and four genotypes viz., CoM 18025, CoVSI 12-2, CoM 18005 and VSI 125-2 were found significantly superior over the standards VSI 08005, MS 10001, Co 09004 and CoC 671 only for cane yield at 16th month crop age (Table 2.a.i).

MLT-I Plant- *Adsali*- Ratoon: Out of total nine genotypes studied, four genotypes viz., CoVSI 12-2, VSI 125-2, CoM 18008 and CoM 18025 were found significantly superior over the standards Co 86032, MS 10001, CoC 671 and Co 09004 for cane yield and sugar yield (Table 2.a.ii).

MLT-*Adsali* (Pooled over two plants and one ratoon crop): In the years 2022-23 and 2023-24 the pooled data over two plants and one ratoon crop at 16th month crop age revealed that, out of nine genotypes evaluated, three genotypes viz., CoM 18025, CoVSI 12-2 and VSI 125-2 were found significantly superior over the standards Co 86032, MS 10001, Co 09004 and CoC 671 (Table 2.a.iii). The genotype CoM 18008 was found superior over the above mentioned four standards only for cane yield.

MLT-II Plant-Preseason: Out of nine genotypes three genotypes viz., CoM 18025, CoVSI 12-2 and VSI 125-2 were found significantly superior over the standards Co 86032, CoC 671 and Co 09004 for cane and sugar yield. All these three genotypes were found significantly superior over the standard VSI 08005 only for cane yield at 14th month crop age (Table 2.b.i).

MLT-I Plant-Preseason-Ratoon: Out of nine genotypes three genotypes viz., PDN 15012, CoVSI 12-2 and CoM 18008 were found significantly superior over the standards Co 86032, CoC 671 and Co 09004 for cane and sugar yield. Whereas one genotype CoM 18025 was found significantly superior over the above three standards only for cane yield (Table 2.b.ii).

MLT-Preseason (Pooled over two plants and one ratoon crop): In the years 2022-23 and 2023-24 the pooled data over two plants and one ratoon crop at 14th month crop age revealed that, out of nine genotypes tested, three genotypes viz., CoM 18025, CoVSI 12-2 and VSI 125-2 were found significantly superior over the standards Co 86032, CoC 671 and Co 09004 for cane and sugar yield. Whereas, two genotypes viz., CoM 18008 and PDN 15012 were found significantly superior over the standard Co 86032 and CoC 671 only for sugar yield (Table 2.b.iii).

MLT-II Plant-*Suru*: Out of nine genotypes five genotypes viz., CoM 18025, CoM 18008, CoVSI 12-2, VSI 125-2 and PDN 15012 were found significantly superior over the standards Co 86032 and Co 09004 for cane and sugar yield at 12th month crop age (Table 2.c.i).

MLT-I Plant-*Suru*-Ratoon: Out of nine genotypes two genotypes viz., CoVSI 12-2 and VSI 125-2 were found significantly superior over the standards Co 86032, MS 10001, CoC 671, Co 09004



and VSI 434 for cane and sugar yield. Whereas, two genotypes namely CoM 18025 and CoM 18008 was found superior over the standard Co 86032, MS 10001, CoC 671, Co 09004 and VSI 434 only for cane yield at 12th month crop age (Table 2.c.ii).

MLT-Suru (Pooled over two plants and one ratoon crop): In the years 2022-23 and 2023-24 the pooled data over two plants and one ratoon crop at 12th

month crop age revealed that, out of nine genotypes studied, three genotypes viz., CoVSI 12-2, CoM 18008 and VSI 125-2 were found significantly superior over the standards Co 86032, MS 10001, CoC 671, Co 09004 and VSI 434 for cane and sugar yield. Whereas, two genotypes namely CoM 18025 and PDN 15012 were found superior over the above five standards only for cane yield (Table 2.c.iii).

Table 2: Performance of sugarcane genotypes in Multi-location trials (SAU's) at VSI

Genotypes	Sugar Yield (t/ha)	Cane Yield (t/ha)	Sucrose (%)	CCS (%)
a.i) MLT-II-Plant-Adsali (Crop Age: 16th month)				
CoM 18025	21.50	160.09	18.83	13.43
CoVSI 12-2	23.60	157.09	20.94	15.03
VSI 125-2	23.75	155.92	21.25	15.23
CoM 18005	20.90	154.58	18.97	13.51
VSI 82-1	23.82	151.95	21.65	15.68
PDN 15012	21.95	150.70	20.49	14.56
CoC 671 (Std.)	19.87	127.23	21.90	15.62
Co 86032 (Std.)	19.73	137.42	20.03	14.38
Co 09004 (Std.)	21.29	135.81	21.85	15.68
MS 10001 (Std.)	20.67	137.32	21.02	15.05
VSI 08005 (Std.)	21.30	143.32	20.69	14.87
CD at 5%	1.53	11.20	0.96	0.67
CV %	4.31	4.59	2.82	2.74
a.ii) MLT-I Plant-Adsali-Ratoon (Crop Age: 12th month)				
CoM 18025	17.85	141.52	17.82	12.62
CoVSI 12-2	20.95	139.42	20.98	15.05
VSI 125-2	19.33	137.65	19.48	14.05
CoM 18008	19.40	136.19	19.80	14.24
CoC 671 (Std.)	16.68	103.93	22.15	16.05
Co 86032 (Std.)	16.93	121.84	19.44	13.90
Co 09004 (Std.)	13.67	89.22	21.19	15.30
MS 10001 (Std.)	15.36	103.37	20.59	14.87
VSI 08005 (Std.)	19.75	134.29	20.64	14.70
CD at 5%	2.05	12.62	1.19	0.91
CV %	7.20	6.35	3.56	3.79
a.iii) MLT-Adsali (Pooled over two plants and one ratoon crop)				
CoM 18025	20.73	152.83	18.99	13.54
CoVSI 12-2	22.12	149.56	20.64	14.79
VSI 125-2	21.45	146.87	20.31	14.58
CoM 18008	20.19	142.64	19.76	14.16
CoC 671 (Std.)	18.63	118.49	21.91	15.75
Co 86032 (Std.)	18.45	130.30	19.77	14.15
Co 09004 (Std.)	18.10	119.17	21.12	15.20
MS 10001 (Std.)	18.83	125.49	20.81	14.99
VSI 08005 (Std.)	20.39	138.05	20.63	14.77
CD at 5%	1.98	12.21	0.97	0.74
CV %	6.14	5.42	2.91	3.08

Table 2: Performance of sugarcane genotypes in Multi-location trials (SAU's) at VSI (Contd....)

b.i) ML II Plant Preseason (Crop Age: 14th month)				
CoM 18025	20.55	154.49	18.65	13.30
CoVSI 12-2	21.71	151.01	20.06	14.38
VSI 125-2	20.30	144.02	19.49	14.08
CoC 671 (Std.)	17.75	120.95	20.62	14.68
Co 86032 (Std.)	17.70	126.77	19.65	13.97
Co 09004 (Std.)	18.75	120.22	21.57	15.57
MS 10001 (Std.)	19.24	131.06	20.54	14.67
VSI 08005 (Std.)	19.49	134.19	20.21	14.55
CD at 5%	2.28	14.91	0.86	0.67
CV %	7.31	6.78	2.62	0.83
b.ii) MLT -I Plant-Preseason -Ratoon				
PDN 15012	19.12	136.30	19.65	14.03
CoVSI 12-2	19.34	135.18	19.93	14.30
CoM 18025	16.99	136.32	17.44	12.46
CoM 18008	17.83	127.80	19.57	13.96
CoC 671 (Std.)	15.51	102.40	20.98	15.14
Co 86032 (Std.)	15.72	114.28	19.27	13.76
Co 09004 (Std.)	13.77	88.60	21.62	15.55
MS 10001 (Std.)	18.27	124.40	20.30	14.68
VSI 08005 (Std.)	20.27	138.27	20.34	14.68
CD at 5%	2.07	13.38	0.85	0.67
CV %	7.42	6.61	2.61	2.87
b.iii) MLT-Preseason (Pooled over two plants and one ratoon crop)				
CoM 18025	19.21	146.29	18.34	13.11
CoVSI 12-2	21.05	144.69	20.21	14.54
VSI 125-2	19.69	138.32	19.70	14.21
PDN 15012	19.50	135.64	20.06	14.38
CoM 18008	19.53	134.65	20.21	14.49
CoC 671 (Std.)	17.09	113.37	21.00	15.08
Co 86032 (Std.)	16.99	122.38	19.48	13.88
Co 09004 (Std.)	17.73	112.88	21.70	15.69
MS 10001 (Std.)	19.08	127.31	20.81	14.98
VSI 08005 (Std.)	20.00	134.38	20.06	14.91
CD at 5%	2.00	13.97	0.78	0.59
CV %	6.51	6.46	2.35	2.48
c.i) ML-II Plant-Suru (Crop Age: 12th month)				
CoM 18025	19.52	144.58	18.82	13.49
CoM 18008	20.00	143.64	19.32	13.93
CoVSI 12-2	20.90	143.51	20.21	14.57
VSI 125-2	20.43	140.36	20.38	14.55
PDN 15012	19.29	139.61	19.36	13.82
CoC 671 (Std.)	17.97	116.36	20.41	15.45
Co 86032 (Std.)	16.76	121.44	19.43	13.80
Co 09004 (Std.)	14.49	98.05	20.54	14.76
MS 10001 (Std.)	18.16	121.49	20.83	14.95
VSI 08005 (Std.)	19.91	130.18	21.10	15.30
VSI 434 (Std.)	13.08	84.69	21.46	15.42
CD at 5%	2.51	17.44	0.82	0.60
CV %	6.70	6.63	1.94	1.97



Table 2: Performance of sugarcane genotypes in Multi-location trials (SAU's) at VSI (Contd....)

c.ii) MLT - I Plant- <i>Suru</i>-Ratoon				
CoM 18025	17.46	134.46	18.40	12.99
CoVSI 12-2	19.78	132.86	20.67	14.90
VSI 125-2	19.25	130.19	20.57	14.79
CoM 18008	18.85	130.69	20.17	14.43
CoC 671 (Std.)	14.18	92.71	21.32	15.29
Co 86032 (Std.)	16.86	113.52	20.78	14.85
Co 09004 (Std.)	12.78	87.42	20.57	14.63
MS 10001 (Std.)	14.61	99.80	20.55	14.63
VSI 08005 (Std.)	18.16	124.09	20.51	14.65
VSI 434 (Std.)	11.85	77.05	21.44	15.38
CD at 5%	2.02	15.43	0.45	0.40
CV %	6.03	6.58	1.05	1.31
C.iii) MLT-<i>Suru</i> (Pooled over two plants and one ratoon crop)				
CoVSI 12-2	20.86	139.23	20.74	14.99
CoM 18008	20.08	137.47	20.29	14.61
VSI 125-2	19.90	135.83	20.37	14.65
CoM 18025	18.51	139.55	18.54	13.26
PDN 15012	18.50	133.41	19.38	13.86
CoC 671 (Std.)	16.71	105.07	22.00	15.89
Co 86032 (Std.)	16.79	117.27	20.06	14.33
Co 09004 (Std.)	15.27	99.27	21.28	15.30
MS 10001 (Std.)	16.75	112.51	20.71	14.87
VSI 08005 (Std.)	18.73	126.48	20.64	14.80
VSI 434 (Std.)	13.89	86.70	22.11	15.95
CD at 5%	2.18	12.74	1.03	0.84
CV %	7.55	6.35	3.07	3.46

Multi-location Trials (VSI)

The multi-location trials were conducted by VSI in different agro-climatic zones of Maharashtra at selected sugar mills and at VSI farm to test the newly developed genotypes by VSI, Pune; CSRS, Padegaon and promising genotypes identified under AICRP(S). A set of nine genotypes viz., CoVSI 18121, CoVSI 19121, VSI 15002, CoVSI 16002, CoVSI 17001, Co 11015, Co 12009, Co 13008 and PDN 15012 along with five standards VSI 434, MS 10001, Co 86032, CoM 0265 and VSI 08005 (VSI 12121) were tested at VSI's Patharwala farm and Bhimashankar SSK, Pune (table 3).

MLT- II Plant- *Suru* (Patharwala farm) : Out of nine entries tested only one genotype Co 13008 were found significantly superior over the standard Co 86032 for cane and sugar yield. Whereas, two genotypes namely PDN 15012 and CoVSI 18121 were found numerically higher over the standards VSI 08005 and Co 86032 for cane and sugar yield (table 3.a).

MLT-*Suru* (Pooled over two plants and one ratoon crop) (Bhimashankar SSK, Pune): Out of nine entries tested four genotypes Co 13008, PDN 15012, CoVSI 18121 and Co 12009 were found superior over the standards Co 86032 and VSI 434 for cane and sugar yield (table 3.b).

Propagation of nucleus seed and inspection of breeders seed of released varieties and promising genotypes

The morphologically pure seed selected for production of nucleus seed of sugarcane varieties and after MHAT treatment (MHAT at 54°C for 2.5 hours at 95-99 % RH) it was planted as the nucleus seed on an area of 6.89, hectare as per month-wise planting schedule provided by farm section and grown at Manjari, Vasantdada, Naigaon, Lonarwadi, Patharwala & Nagpur farms of the Institute during planting season 2023-24 (table 4). The nucleus seed of newly released three varieties CoM 11082, PDN 15012 and PDN 13007 by CSRS, Padegaon was procured and planted.

Table 3: Performance of sugarcane genotypes in MLT at selected VSI's farms and sugar mills

Genotypes	Sugar Yield (t/ha)	Cane Yield (t/ha)	Sucrose (%)	CCS (%)
a) MLT- II Plant - Suru (Crop Age : 12th month) - Patharwala farm				
Co 13008	24.15	166.18	20.37	14.54
PDN 15012	22.93	156.89	20.47	14.63
CoVSI 18121	23.06	152.54	20.98	15.07
Co 12009	21.40	151.78	19.65	14.05
CoM 0265 (Std.)	20.45	157.00	18.74	13.37
VSI 08005 (Std.)	21.38	145.22	20.61	14.70
Co 86032 (Std.)	18.79	134.58	20.47	14.63
CD at 5%	5.10	23.26	2.64	2.54
CV %	11.14	7.31	5.96	8.01
(Pooled over two plants and one ratoon crop)				
Co 13008	20.13	144.21	19.51	13.95
PDN 15012	20.90	142.82	20.41	14.62
CoVSI 18121	20.63	140.22	20.54	14.70
Co 12009	18.87	132.63	19.91	14.23
Co 11015	16.32	108.11	21.04	15.06
Co 86032	16.89	118.56	19.95	14.24
CoM 0265	19.33	140.20	19.17	13.79
VSI 08005	19.73	133.33	20.66	14.78
MS 10001	19.76	128.11	21.39	15.43
VSI 434	15.86	101.56	21.68	15.61
CD at 5%	1.90	10.85	0.57	0.53
CV %	6.17	5.06	1.69	2.20

Table 4: Variety wise nucleus seed raised at VSI farms

Variety	Nucleus seed area (ha)						Total Area (ha)
	Manjari	Vasantdada	Naigaon	Lonarwadi	Patharwala	Nagpur	
CoC 671	0.00	0.00	0.00	0.04	0.00	0.01	0.04
Co 86032	0.25	0.07	0.28	0.27	0.09	0.01	0.97
CoM 0265	0.00	0.13	0.41	0.55	0.44	0.00	1.52
VSI 434	0.00	0.00	0.03	0.09	0.00	0.01	0.12
Co 92005	0.00	0.00	0.00	0.00	0.00	0.01	0.01
CoVSI 03102	0.00	0.00	0.00	0.09	0.00	0.01	0.10
MS 10001	0.00	0.00	0.06	0.14	0.47	0.01	0.68
VSI 08005	0.10	0.09	0.18	0.19	0.47	0.20	1.23
CoM 11082	0.02	0.00	0.00	0.02	0.06	0.00	0.10
PDN 13007	0.04	0.00	0.00	0.03	0.06	0.00	0.13
PDN 15012	0.05	0.00	0.14	0.26	0.14	0.01	0.60
CoVSI 18121	0.25	0.13	0.44	0.20	0.26	0.10	1.38
Total (ha)	0.71	0.41	1.54	1.87	1.99	0.37	6.89



Under the Chairmanship of Principal Scientist, Crop Production and Protection the seed inspection committee of the Institute comprised of the scientists from plant breeding, entomology and pathology visited breeders' seed plots (total 34.96 ha) grown at Manjari (0.20 ha), Vasantdada (1.03 ha), Naigaon (10.00 ha), Lonarwadi (10.01 ha) and Patharwala (13.72 ha) farms of the Institute and recorded the observations as per schedule. On the basis of the observations, the breeders' seed plots of varieties viz., CoC 671, Co 86032, CoM 0265, VSI 434, CoVSI 03102, MS 10001, VSI 08005, Co 92005, PDN 15012 and CoVSI 18121 were grown on an area of 34.96 ha and certified before the distribution of seed to sugar mills.

HYBRIDIZATION

Total 1305 clones under different groups are maintained at SBC, Amboli and evaluated for yield and quality parameters. Of these 82.12 % genotypes were flowered. The favourable climate and rainfall (6827.40 mm) has helped the flowering during the year. Total of 92 pistils and 56 pollen parents were used as parental lines in crossing program. Under the genetic base broadening programme of sugarcane, 16 new sugarcane germplasm lines were included in the germplasm maintained at Sugarcane Breeding Centre, Amboli. The sugarcane germplasm maintained as mentioned below -

<i>Saccharum species</i>	
<i>S. officinarum</i>	52
<i>S. barberi</i>	07
<i>S. spontaneum</i>	25
<i>S. robustum</i>	05
<i>Related species of Saccharum</i>	
<i>Erianthus species</i>	07
<i>Narenga prophyrocoma</i>	01
<i>Others</i>	
Interspecific Hybrids (ISH)	131
Indian Hybrids	747
Foreign Hybrids	35
Genetic stocks developed at VSI	289
Inter Generic Hybrids (IGH)	06
Total	1305

Total 1398.50 gm of fluff was received from SBI, Coimbatore and 4857.95 gm of fluff was collected from SBC, Amboli during 2023-24. Details of crosses effected and total quantity of fluff is mentioned below in table 5. The fluff will be sown in the month of June, 2024 to raise the Ground Nursery I (2024 batch). The details of seedlings raised from fluff (2023 Batch) are given in table 6 and Fig.02.

Table 5: Details of crosses effected and total quantity of fluff (Batch 2024)

Sr. No.	Particulars	Number crosses / PC / GC	Quantity of fluff received (gm.)
A	Sugarcane Breeding Institute, Coimbatore		
	a. Station crosses	27	645.05
	b. Poly crosses (PC' s)	05	44.83
	General Collection (GC' s)	09	271.62
	Total (A)	41	961.50
B	DHG, Agali crosses		
	a. Agali crosses	07	292.00
	b. General Collection (GC' s)	06	145.00
	Total (B)	13	437.00
	Total (A+B)	54	1,398.50
C	Sugarcane Breeding Centre, Amboli		
	a. Commercial Crosses & Germplasm	115	2,009.37
	b. Field crosses	61	832.53
	c. Poly crosses (PC's)	59	1,327.29
	d. General Collection's (GC's)	48	688.76
	Total (C)	283	4,857.95
	Total (A+B+C)	337	6,256.45

Table 6: Summary of the seedlings grown in ground nursery-I (2023 Batch)

Sr. No.	Particulars	Number crosses / PC / GC	Quantity of fluff received (gm.)	Total seedlings transplanted
A	Sugarcane Breeding Institute, Coimbatore	15	355.76	827.00
	a. Station crosses	03	30.14	93.00
	b. Poly crosses (PC's)	16	297.25	561.00
	General Collection (GC' s)			
	Total (A)	34	683.15	1481.00
B	DHG, Agali crosses			
	a. Agali crosses	04	147.00	54.00
	Total (B)	04	147.00	54.00
	Total (A+B)	38	830.15	1535.00
C	Sugarcane Breeding Centre, Amboli			
	a. Commercial Crosses & Germplasm	151	3470.69	2962.00
	b. Field crosses	12	181.35	00
	c. Poly crosses (PC's)	51	594.02	1170.00
	d. General Collection's (GC's)	23	288.01	44.00
	Total (C)	237	4534.07	4,176.00
	Total (A+B+C)	275	5364.22	5,711.00



Fig. 2: Seedlings developed from fluff
(Ground Nursery-I -2023 batch)

First clonal trial (2021 batch)

The Clonal Trial-I (2021 batch) conducted at VSI, out of total 1507 (SBI 311 + VSI 1196) clones under study, total 108 clones (SBI 13, VSI 95) forwarded to Prefinal Varietal Trial (PFVT) (2021 batch).

The Clonal trial I (2021 batch) conducted at Patharwala farm, Dist.Jalna, out of total 119 (SBI 45 + VSI 74) clones under study, total twelve clones (SBI 03 and VSI 09) forwarded to PFVT (2021 batch).

The selections were made on the basis of number of millable canes, HR Brix cane diameter, millable cane height, flowering behavior, growth habit, leaf clasping, natural incidence of diseases and pests.

All India Coordinated Research Project on Sugarcane [AICRP(S)]

As per the approved technical programme of AICRP(S) plant breeding under crop improvement, following four zonal varietal trials (ZVT) were conducted;

- Initial varietal trial,
- Advanced varietal trial plant I,
- Advanced varietal trial plant II and
- Advanced varietal trial plant I Ratoon

The performance of promising genotypes under AICRP (S) different trials are given in table 7.

Sugarcane genetic resources, collection, evaluation, characterization and utilization of germplasm evaluation

The sugarcane database was created by recording data in the flowering sugarcane germplasm clones on flowering behavior and pollen fertility. The other observations like HR Brix %, number of millable canes, stalk diameter, stalk height, and number of internodes in all the available sugarcane germplasm at SBC, Amboli.

Germplasm utilization

Marcotting technique for the controlled crossing was utilized and total 1397 canes were marcotted. During the year, total 82.12% clones have flowered. Total 235 bi-parental crosses were effected at SBC, Amboli.

Cytogenetic studies in distant hybrids in sugarcane

The back cross progenies (BC1) from *Erianthus* x *Saccharum* intergeneric hybrids and commercial sugarcane flowered at SBC, Amboli i.e. VSI 121-50 and VSI 121-52 (ES 09 X Co 89003) involving *Erianthus* and *Saccharum* blood were fixed for chromosomal study and meiotic behavior. VSI 121-50 chromosomal study made and observed different meiotic stages with Metaphase-II, Anaphase-II, dyad formation, laggards during equatorial plate during Anaphase-II (Fig.03.a to f different stages). The hybrid showed with $2n=116$ to 128 and also some chromosome elimination had occurred. During Metaphase-II stage disoriented spindle also observed in BC1 generation. The BC1 shows predominantly bivalent formation and abnormalities in chromosome segregation. The efforts are being made to produce BC2 generation with the utilization of BC1 hybrids i.e. VSI 121-50 and VSI 121-52 in the hybridization programme at SBC, Amboli to obtained *Erianthus* gene pool in subsequent generation with commercial sugarcane varieties. Some BC2 generation seedlings were transplanted in the Ground Nursery-II and will be used further for obtaining *Erianthus* genome up to commercial level in future.

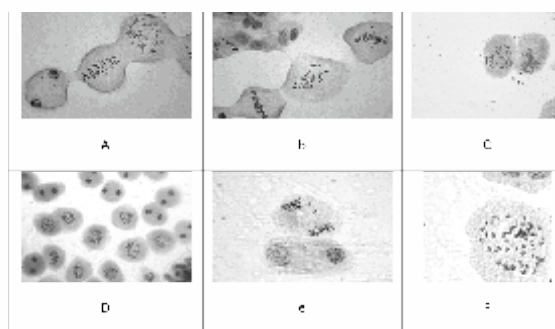

Fig 3: Meiotic Study in the *Erianthus* X *Saccharum* hybrids back cross progeny (BC1-VSI 121-50) ES 9 X Co 89003 a Dyad Formation and Metaphase-II, b-Metaphase-II and chromosome on equatorial plate c and d- Dyad formation during Anaphase-I, e- laggards on equatorial plate during Anaphase-II, f- bivalent formation in Prophase -I of meiosis



Table 7: Performance of sugarcane genotypes in AICRP(S) trials at VSI, Pune

Genotype	Sugar Yield (t/ha)	Cane Yield (t/ha)	Sucrose (%)	CCS (%)
Initial Varietal Trial (Crop age: 12th month)				
Co 20003	23.13	159.49	20.28	14.50
Co 20001	18.17	147.29	17.51	12.33
CoSnk 20102	17.49	141.32	17.37	12.37
CoM 20082	17.28	143.18	16.93	12.06
Co 86032 (Std.)	17.04	119.56	19.90	14.25
CoC 671 (Std.)	14.91	99.89	20.78	14.92
Co 09004 (Std.)	15.86	110.68	20.15	14.33
CD at 5%	2.24	13.82	0.96	0.84
CV %	8.61	7.18	3.06	3.74
Advanced Varietal Trial - I Plant (Crop age: 12th month)				
CoVc 18061	20.44	149.26	18.98	13.70
Co 18003	20.62	144.37	19.85	14.30
CoVSI 18121	20.10	141.88	19.67	14.16
Co 18012	19.94	140.82	19.60	14.16
Co 86032 (Std.)	16.64	121.08	19.05	13.75
CoC 671 (Std.)	16.07	106.92	20.84	15.02
Co 09004 (Std.)	18.03	119.05	21.05	15.14
CD at 5%	2.27	13.22	0.99	0.77
CV %	7.79	6.34	3.05	3.31
Advanced Varietal Trial - II Plant (Crop age: 12th month)				
Co 17012	21.11	157.18	18.59	13.42
CoVc 17061	20.48	155.86	18.36	13.13
Co 17004	20.74	154.38	18.70	13.44
MS 17082	19.98	148.55	19.02	13.45
Co 17003	21.49	145.37	20.66	14.79
Co 17002	20.03	140.98	19.74	14.20
Co 17005	19.71	135.72	20.26	14.53
VSI 22121	17.93	154.64	16.43	11.62
Co 86032 (Std.)	16.84	123.09	19.01	13.68
CoC 671 (Std.)	17.48	116.74	20.76	14.98
Co 09004 (Std.)	18.63	121.62	21.16	15.31
CD at 5%	1.83	12.39	0.89	0.75
CV %	5.85	5.44	2.76	3.25
Advanced Varietal Trial - Ratoon - I Plant (Crop age: 11th month)				
Co 17012	17.30	130.44	18.56	13.26
CoVc 17061	17.89	127.09	19.63	14.10
Co 17004	17.86	125.35	19.71	14.26
Co 86032 (Std.)	14.47	109.11	18.76	13.26
CoC 671 (Std.)	14.01	92.38	20.94	15.17
Co 09004 (Std.)	14.69	96.19	21.12	15.27
CD at 5%	2.13	15.78	1.02	0.80
CV %	8.83	9.34	3.06	3.33

Table 7: Performance of sugarcane genotypes in AICRP(S) trials at VSI, Pune (Contd.)

Advanced Varietal Trial (Pooled over two plants and one ratoon crop)				
Co 17012	20.68	149.90	19.06	13.75
Co 17004	20.50	145.78	19.49	14.07
CoVc 17061	19.92	145.44	19.10	13.73
MS 17082	18.83	137.34	19.25	13.66
Co 86032 (Std.)	16.62	120.13	19.30	13.81
CoC 671 (Std.)	16.93	109.81	21.26	15.40
Co 09004 (Std.)	18.10	117.75	21.20	15.36
CD at 5%	1.82	13.58	0.90	0.71
CV %.	6.12	6.52	2.69	2.98

First clonal trial (2021 batch)

The Clonal Trial-I (2021 batch) conducted at VSI, out of total 1507 (SBI 311 + VSI 1196) clones under study, total 108 clones (SBI 13, VSI 95) forwarded to Prefinal Varietal Trial (PFVT) (2021 batch).

The Clonal trial I (2021 batch) conducted at Patharwala farm, Dist.Jalna, out of total 119 (SBI 45 + VSI 74) clones under study, total twelve clones (SBI 03 and VSI 09) forwarded to PFVT (2021 batch).

The selections were made on the basis of number of millable canes, HR Brix cane diameter, millable cane height, flowering behavior, growth habit, leaf clasping,

Utilization of inter-specific hybrids (ISH) involving different species of *Saccharum* and related genera i.e. *Erianthus*

The ISH and *Erianthus* involving intergeneric hybrids i.e. BC1 and BC2 crosses performed at SBC, Amboli and also some selections made in Ground Nursery-II (2022) for further evaluation. The BC1 progenies were utilized at SBC, Amboli to produce next BC2 generation and which helps to introduce *Erianthus* gene pool in commercial sugarcane crop. True hybrids were selected on the basis of morphology and quality character and such selected clones will be evaluated along with standards for identification of genetic stock for drought, salinity and high fibre percent.

Evaluation and identification of climate resilient IGH and ISH genetic stocks and screening of VSI's genotypes for drought tolerance (Plant crop I)

Out of total twelve ISH and IGH genotypes tested

for moisture stress tolerance, none of the genotype was found significantly superior to the standards CoM 0265 and VSI 12121 under moisture stress for cane and sugar yield. While, the genotype ISH 573 was found superior over the standards CoM 88121 and Co 86032 for the cane yield and sugar yield while, two genotypes viz., IGH 806 and ISH 528 were found significantly superior over the standards Co 86032 and CoM 88121 only for cane yield. Whereas, four genotypes namely, ISH 526, ISH 545, ISH 554 and ISH 558 showed less percent reduction (stress verses control) as compared to standards (table 8). The VSI's eight clones tested along with these clones, none of the genotype was found significantly superior to the standards CoM 0265 and VSI 12121 under moisture stress for cane and sugar yield. But five genotypes, i.e., CoVSI 23121 (64-4), VSI 22121 (56-2), VSI 18008 (109-8), CoVSI 23122 (135-3) and VSI 18001 (109-1) were found significantly superior over the standards Co 86032 and CoM 88121 for cane and sugar yield (table 8.a).





Table 8.a: Evaluation and identification of climate resilient IGH and ISH genetic stocks and VSI's genotypes for drought tolerance

Genotypes	Sugar Yield (t/ha)			Cane Yield (t/ha)			CCS (%)		
	N	S	R	N	S	R	N	S	R
ISH 573	19.11	10.73	43.85	120.69	86.12	28.64	15.83	12.43	21.48
IGH 806	12.12	7.34	39.44	130.78	79.09	39.52	9.24	9.24	0.00
ISH 528	18.79	8.53	54.60	129.57	73.37	43.37	14.49	11.65	19.60
ISH 526	8.99	5.45	39.38	68.75	50.58	26.43	13.02	10.74	17.51
ISH 545	9.42	5.99	36.41	78.67	63.62	19.13	12.08	9.41	22.10
ISH 554	9.36	7.42	20.43	85.87	69.27	19.33	10.93	10.67	2.38
ISH 558	11.12	7.36	31.81	86.57	68.82	20.50	12.86	10.70	16.80
CoVSI 23121	17.92	11.62	35.16	118.98	95.61	19.64	15.06	12.20	18.99
VSI 22121	17.41	9.11	47.67	129.26	92.61	28.35	13.47	9.75	27.62
VSI 18008	19.12	10.77	43.67	129.39	88.09	31.92	14.78	12.21	17.39
CoVSI 23122	20.17	9.86	51.12	138.79	86.49	37.68	14.51	11.31	22.05
VSI 18001	12.71	8.70	31.55	108.33	86.14	20.48	11.70	10.10	13.68
Standards									
CoM 88121	14.43	6.29	56.41	108.85	53.46	20.89	13.27	11.76	11.38
CoM 0265	20.06	10.84	45.96	143.74	88.05	38.74	13.95	12.30	11.83
VSI 12121	17.52	10.32	41.10	120.08	83.67	30.32	14.59	12.36	15.28
Co 86 032	16.68	6.19	62.89	114.62	54.67	52.30	14.55	11.39	21.72
CD at 5 %	2.41	2.37	-	12.96	12.69	-	1.46	2.12	-
CV %	8.55	15.81	-	6.02	9.27	-	5.45	9.45	-

(N – Normal; S- Stress; R -Percent reduction)

Screening of sugarcane genotypes for salinity tolerance- Ratoon of Plant I

Out of total six promising entries tested under ratoon trial in saline and sodic soil conditions, none of the genotype was found superior to the standards

CoM 0265 and VSI 08005 for cane yield and sugar yield in normal soil condition, but three genotypes viz., CoVSI 17002, VSI 17001 and CoVSI 18121 were found superior for cane and sugar yield over the standard CoM 88121 (table 8.b).

Table 8.b: Screening of sugarcane genotypes for salinity stress tolerance

Genotypes	Sugar Yield (t/ha)			Cane Yield (t/ha)			CCS (%)		
	N	S	R	N	S	R	N	S	R
CoVSI 17002	17.55	11.06	36.98	122.07	79.54	34.84	14.34	13.88	3.21
CoVSI 17001	16.54	11.03	33.31	104.90	70.25	33.03	15.77	15.69	0.51
CoVSI 18121	16.15	8.89	44.95	107.14	60.15	43.86	15.10	14.80	1.99
CoM 88121	12.95	6.87	46.95	89.68	47.81	46.69	14.44	14.36	0.55
CoM 0265	17.25	11.23	34.90	124.39	81.54	34.45	13.88	13.79	0.65
VSI 12121	19.13	11.24	41.24	121.38	71.77	40.87	15.75	15.66	0.57
CD at 5 %	2.27	1.75	-	13.89	10.32	-	1.00	1.05	-
CV %	8.59	11.49	-	7.85	10.39	-	3.84	4.15	-

(N – Normal; S- Stress; R -Percent reduction)

TISSUE CULTURE

Tissue culture section works on various objectives such as quality seed production through sugarcane micropropagation, production, research and development of Vasant Urja as a biostimulator, extension, research as well as training for cane development of sugar mills.

The main activities includes

- Production of virus free plantlets as breeder's seed through sugarcane micropropagation technique and distribution to sugar industry in Maharashtra and neighboring states for raising the seed plots through three tier seed production.
- Production, supply, Research and Development (R&D) for improvement of Vasant Urja as a biostimulator.
- Development of thermostable microwave reactor system for Low molecular weight chitosan/chitosan nanocomposites production.
- Applications of Vasant Urja on other crops.
- Development of β -glucan nanocomposite for *Sclerotium* rots management in sugarbeet.
- Staff was also involved in internships / short term research project work to graduate, postgraduate students and guidance to research scholars working for their Ph.D. studies and in extension work to various sugar mills for cane development and visits

to various organizations for collaborative research and development activities. In addition, the staff participated in Dnyanyag, Dnyanlaxmi and other various training programs.

The brief work done on various aspects of sugarcane and development of biostimulator for improvement of sugar and sugarcane productivity are given below.

Sugarcane micropropagation

Efforts were made to improve the quality of tissue culture plantlets by improving the media protocol and inducing abiotic and biotic stress tolerance during their production by using the Vasant Urja and fertilizer incorporated bio-sludge from sugar mills. The section developed suitable micropropagation protocol for PDN 15012 and CoVSI 18121 sugarcane varieties. Section continued the work on optimization of media composition to improve micropropagation protocol for Co 86032, MS 10001, VSI 08005 and CoM 0265. During the year, section has produced 8.69 lakh virus free plantlets of different sugarcane varieties and of which 6.47 lakh plantlets were distributed to the sugar industry and sugarcane growers of Maharashtra as well as adjoining states as breeders' seed for production of foundation seed and subsequently production of quality certified planting material. The production and supply of micropropagated plantlets are given in table 9 and 10.

Table 9: Production of micropropagated sugarcane plantlets

Month	Name of sugarcane varieties										
	Co 86032	VSI 08005	MS 10001	Co 92005	Co 03102	CoM 0265	CoVSI 18121	VSI 434	CoC 671	PDN 15012	Total
Apr. 2022	23290	7263	4710	900	10300	-	-	-	300	-	46763
May	11670	14150	3210	3300	6390	7200	-	-	-	-	45920
Jun.	18310	24330	8100	4290	-	5280	-	-	-	-	60310
Jul.	16090	24960	7410	2610	4455	750	-	4410	480	-	61165
Aug.	35890	10920	15990	1290	3330	8580	-	7230	4350	-	87580
Sep.	39530	15000	9870	11290	5010	6540	-	8190	1500	-	96930
Oct.	42610	21810	6030	-	5010	11070	1170	390	300	-	88390
Nov.	27260	14045	9235	-	-	12220	5345	3790	980	-	72875
Dec.	22410	15310	18235	-	-	12975	3750	-	-	-	72680
Jan. 2023	25760	8910	29960	-	-	13680	6300	-	-	-	84610
Feb.	35990	4680	19060	-	-	3650	2840	-	-	1170	67390
Mar.	57160	10530	290	-	-	3100	3940	-	-	-	83950
Total	355970	171908	141030	23680	34495	85045	23345	24010	7910	1170	868563



Table 10 : Supply of micropropagated plantlets

Particulars	Name of sugarcane varieties									
	Co 86032	VSI 08005	MS 10001	Co 92005	CoVSI 03102	CoM 0265	CoVSI 18121	VSI 434	CoC 671	Total
I) Maharashtra										
A. Factories(10)	59950	66700	31600	17100	18050	9500	-	2900	12000	217800
B. TAO (2)	4400		-	3500	100	1500	600	-	-	10100
C. Other organization (11)	18800	1000	1500	-	1000	1725	1000	-	-	25025
D. Farmers (427)	170995	24950	26913	2570	6605	20720	6550	3203	580	263086
E. VSI *	9600	2260	3200	30	1900		750	7500	1325	26565
Total (I) = A+B+C+D	263745	94910	63213	23200	27655	33445	8900	13603	13905	542576
II) Other states										
A. Factories/Govt. Organization (7)	46100	19000	2000	-	400	25150	-	-	5400	98050
B. Farmers (7)	815	1140	1235	550	600	-	1625	660	-	6625
Total (II)=A+B	46915	20140	3235	550	1000	25150	1625	660	5400	104675
Total=I+II	310660	115050	66448	23750	28655	58595	10525	14263	19305	647251

*Indicates plantlets supplied free of cost for field experiment

Vasant Urja

The section is actively worked in the production, supply, and research & development of Vasant Urja as a biostimulator. This entails investigating its effects on plant growth and productivity, as well as optimizing application methodologies. Technology Transfer agreement with the BARC Mumbai. Section produced and supplied the Gamma Irradiated Chitosan (Nanoparticles) to farmers for sugarcane and other crops. It is becoming a very popular agri input in farmers. For the compliances with FCO all the scientific information regarding the Quality parameters, toxicity studies and the bio-efficacy data has been generated (Fig.1). The scientific analysis with the FCO recommended analytical laboratories having

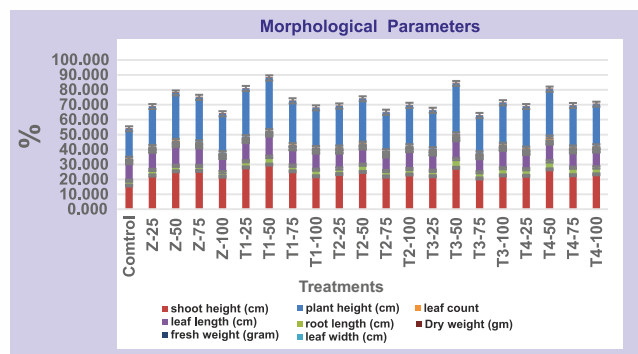

Fig 1. Bio-efficacy study of Vasant Urja with sugarcane TCP's

NABL accreditation, it has been found Vasant Urja is within the limits of all the quality parameters has no toxicity to any beneficial organism and has 2 year's shelf life. The multilocation bio-efficacy trials indicated 4.9 q/ha yield enhancement in green gram and 18t/ha cane yield in sugarcane.

The supply of Vasant Urja in terms of quantity and income generation remains at the top among the different agricultural inputs sold by this institute. This year, 1,44,952 liters of Vasant Urja were produced, with 1,50,340 liters supplied to farmers within and outside Maharashtra. The quality production of Vasant Urja was enhanced by adding more equipment to the infrastructure and improving the methods for the development of materials for gamma irradiation, the gamma irradiation process, as well as the formulation for the finished product. The shelf life analysis data have indicated that there has been no change in the quality parameters and efficacy of Vasant Urja, as physically tested with referral batch samples stored for a 16-month period.

For the promotion of Vasant Urja for other crops, a one-day workshop on the topic "Application of Vasant Urja for Sustainable Agriculture" was organized on 28th July to celebrate World Natural Conservation Day. One hundred and forty-seven organizations participated in the workshop, creating history in VSI's agricultural

input supply by signing 21 agreements in one day. The workshop was inaugurated by Dr. R.B. Deshmukh, Ex-Vice Chancellor of MPKV and Ex-Director of the Agricultural Science & Technology Division, VSI Pune who served as the Chief Guest. Prof. Dr. Prashant Bodake, Head, Department of Agronomy, Dr. Balasaheb Sawant Konkan Krishi Vidypeeth, Dapoli, Dr. R.M. Naik, Ex-Professor & Head of the Biochemistery Department, Mahatma Phule Krishi Vidypeeth, Rahuri, Dr. R.B. Sonawane, In-charge of Onion and Grape Research Center in Pimpalgaon Baswant, Nashik, and Dr. A.D. Kadlag, Principal Scientist & Head of Crop Production and Crop Protection sections, VSI, delivered lectures on the merits of Vasant Urja in different crops for sustainable productivity. Additionally, two Krishiseva owners and three farmers shared their experiences with Vasant Urja applications, highlighting enhanced crop productivity, quality, and economics.

Research and development activities for application of Vasant Urja

Various activities related to Vasant Urja's multifarious applications were taking places with different crops.

Vasant Urja, chemical nutrient enriched biosludge hydrogel and beneficial microbes integrated soil mixture

Experiments were carried out to develop a better soil mixture for tissue culture plantlets as well as single eye bud settlings. Integration of biosludge enriched with chemical fertilizers and beneficial bacteria and hydrogel has enhanced the growth of tissue culture plantlets. A significant increase was observed in plantlet survival (19.62%), plant height (63.06%), leaf length (28.32%), leaf width (37.23%), root number (71.87%) and biomass accumulation (118.47%). Moreover, improvements were noted in chlorophyll-a (49.10%), chlorophyll-b (24.39%), total chlorophyll (40.67%), and carotenoid (33.74%) levels, respectively (Fig.2).

Sugarcane SEB's were irrigated at 48 hour intervals to observe the effects of hydrogel in water deficit conditions. Morphological attributes, including total height, leaf length, number of roots, germination percentage, Timson's index, and germination rate index, showed high statistical significance in growth



Fig. 2: Effect of Vasant Urja, beneficial microbes and Hydrogelenriched bio-sludge.

when bio-sludge enriched with 50 ppm Vasant Urja and 5 ml/L microbial consortia was applied, followed by T5 tratment (bio-sludge enriched with 25 ppm Vasant Urja and 10 ml/L microbial consortia). Leaf width was found to be higher in T5 tratment followed by T3 tratment. Whereas, the number of leaves was higher in T5, T6, T7 treatment, followed by T10 treatment.

Vasant Urja-Thiourea nanocomposite

The data obtained from the third plant and the second ratoon crop revealed significant findings among the treatments. Irradiated chitosan @ 50 ppm and thiourea @ 500 ppm recorded significantly higher juice quality parameters, including juice purity (95.09%), sucrose content (21.26%), Brix percentage (22.35%), and CCS percentage (16.22%) at 0.6 IW/CPE level. Additionally, the treatment resulted in higher tillers per hectare at 90 DAP, reaching 62.11 thousand, and average single cane weight 1.55 kg in 0.6 IW/CPE and 1.30 kg in 0.3 IW/CPE with average internode length 12.06 cm. Moreover, cane yield reached 87.29 t/ha in 0.6 IW/CPE and 59.86 t/ha in 0.3 IW/CPE, while, CCS yield was 14.14 t/ha in 0.6 IW/CPE and 8.59 t/ha in 0.3 IW/CPE.

Specifically, the treatment involving the application of 100 ppm normal chitosan, sett dipping for 30 minutes, and foliar spray at 30, 60, and 90 days after planting (DAP) demonstrated a significant increase in the number of millable canes per hectare (NMC/ha) with significantly higher NMC in Variety CoM 0265 (48.20 thousand/ha), Co 86032 (53.64 thousand/ha), and VSI 08005 (46.69 thousand/ha). Juice quality parameters in treatment 3 IW/CPE level, including juice purity



(90.82%), sucrose content (19.07%), and Brix percentage (21.01%), also showed significant improvements.

Preparation and evaluation of nano conjugates effect on different crops

Development of Chitosan-Cry Protein Nanocomposite

The Bt. protein nanoconjugate was developed and evaluated for its efficacy against sugarcane borer and sugarbeet leaf borer. A new method optimized for microwave-based chitosan nanoparticle synthesis indicated the 86 nm size of chitosan nanoparticles. Significantly, superior results were observed at 96 hours with larval size 4th to 5th instar in bioassay Bt-chitosan nano-conjugate @ 5mg/L for in vitro assays with sugarcane borer larvae. In vitro insect bioassay performed against *Spodoptera littoralis* @5mg/L showed the highest mortality with the same concentration.

Evaluation of Chitosan nanoconjugates with Copper and B-Glucan

A method for bi-polymeric Nano conjugate synthesis with copper nanoparticles, as well as β -glucan from the sugar beet pathogen *Sclerotium rolfisii*, was developed. The nanoconjugate was characterized with standard protocols, prepared, and evaluated in sugarcane and sugarbeet fields. The highest CCS (15.29%) in sugarcane was achieved with the treatment of Chitosan-Copper- β -glucan nanocomposite at 25 ppm.

Chitosan from *Sclerotium rolfisii* at 75 ppm showed the highest sugarbeet yield (125 t/ha) compared to the control (66 t/ha). There was a 70% reduction in bulb rot disease. Additionally, there was significant enhancement in defense enzyme activity, with a 46.15% increase in Chitinase activity and 55.5% increase in β 1.3 glucanase activity compared to the control. An application for patent approval for Chitosan- β -glucan nanocomposite has been filed, as it is a unique development, a firsttime occurrence globally. The patent application has been published and is undergoing examination (Fig.3).

Silver nano-conjugate has been synthesized and provided to the Pathology section for evaluating its activity in the field. The third-year report has been presented by the Pathology Section. The poster

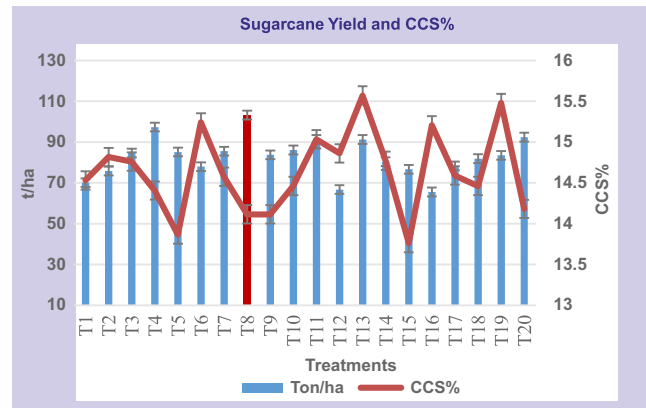

Fig. 3 Effect of chitosan nanoconjugates with copper and B-Glucan on yield and CCS % of sugarcane

presented on the effect of Silver nanoconjugate on sugarcane for the management of sugarcane diseases won the first prize at the International Conference at VSI

Evaluation of Vasant Urja for sugarcane and sugar productivity

The field trial for the evaluation of non-irradiated Vasant Urja (Normal chitosan) showed significant results on sugarcane growth across three varieties. The data obtained from the third plant and the second ratoon crop revealed significant findings among the treatments. Specifically, treatment T5, involving the application of 100 ppm normal chitosan, sett dipping for 30 minutes, and foliar sprays at 30, 60, and 90 days after planting (DAP), demonstrated a significant increase in the number of millable canes per hectare (NMC/ha) across all tested varieties. Notably, treatment T5 exhibited significantly higher NMC in Variety CoM 0265 (48.20 thousand/ha), Co 86032 (53.64 thousand/ha), and VSI 08005 (46.69 thousand/ha). Furthermore, treatment T5 resulted in significantly higher cane yield (t/ha) and commercial cane sugar (CCS) yield (t/ha) across all three varieties. In the third plant, the recorded cane yield was 93.02 t/ha in CoM 0265, 89.08 t/ha in Co 86032, and 95.88 t/ha in VSI 08005. Additionally, CCS yield was 12.67 t/ha in CoM 0265, 12.78 t/ha in Co 86032, and 13.38 t/ha in VSI 08005. Moreover, Co 86032 and VSI 08005 exhibited significantly higher plant heights, measuring 280.67 cm and 309.22 cm respectively.

In the second ratoon crop, treatment T5 recorded significantly higher tillers/ha, with 165.68 thousand per hectare in CoM 0265, 186.07 thousand per hectare in Co 86032, and 173.68 thousand per hectare in

VSI 08005. Additionally, treatment T5 resulted in significantly higher average single cane weight in Co 86032 (1.72 kg) and VSI 08005 (1.69 kg), while, treatment T6 led to higher average single cane weight in CoM 0265 (1.80 kg). Furthermore, treatment T4 demonstrated significantly higher cane yield in Co 86032 (122.42 t/ha), and treatment T6 showed higher cane yield in CoM 0265 (128.03 t/ha) and VSI 08005 (112.06 t/ha). Treatment T4 also resulted in significantly higher CCS yield in Co 86032 (19.05 t/ha), while, treatment T6 led to higher CCS yield in CoM 0265 (18.08 t/ha) and VSI 08005 (17.31 t/ha).

Collaborative research with external organizations/ Institutes under MoU/MTA

Collaborative research with Bhabha Atomic Research Centre (BARC), Mumbai.

Evaluation of benefits of the use of distillery generated, biosludge, chemical fertilizers and beneficial microbes and hydrogel enriched biosludge in soil mixture for sugarcane TC and Single Eye Bud plants has been carried out. The results are promising in order to improve in growth, survival, and vigor of TC plantlets as well as Single Eye bud plants.

Assessments of biochemical parameters find out the cellular and biochemical parameters showed the enhancement of growth attributes in TCP and SEB. Integration of biosludge in the soil mixture for TC plantlet has enhanced survival percent, growth of TC plantlets and reduced the acclimatization period and the quality of TC plantlets. Field level evaluation will be undertaken to find optimal doses and recommendations for large scale commercial applications to enhance the girth of TC plantlets during 2023-24.

Collaborative research with ICAR-National Institute of Abiotic Stress Management (NIASM), Baramati

Phenomics studies were undertaken to evaluate the effects of foliar sprays of Vasant Urja biostimulator on abiotic stress tolerance in sugarcane TC and SEB plants (Co 86032, VSI 08005, MS 10001 and CoM 0265). Vasant Urja has shown superiority over the Salicylic Acid, Silisic acid and bacterial biopolymer developed by NIASM. Phenomics data confirmed efficacy of irradiated Vasant Urja for moisture stress tolerance in

TC plantlets of Co 86032, VSI 08005 and CoM 0265. Two year trial on the use of Vasant Urja biostimulators under deficit irrigation on Okra at ICAR-NIASM, Baramati has been completed. Vasant Urja was found superior to chemical elicitors (like Silicic Acid, Salicylic Acid and Thiourea) for inducing stress tolerance. Irradiated Vasant Urja has better yield enhancing activity than chemical stress tolerance inducing elicitor compounds like Silicic acid, Thiourea and bacterial polymer.

Collaborative research with Dr. Balasaheb Sawant Kokan Krishi Vidyapeeth (DBSKKV), Dapoli

Multi-location trials conducted at VSI, Pune (Co 86032, VSI 08005, CoM 265); ARS-Napane (Vaibhavwadi) & DBSKKV, Dapoli (Co 92005, CoVSI 3102 and Co 86032) for evaluating Vasant Urja as Biostimulator in different Sugarcane varieties. Application of 100 ppm non-irradiated Vasant Urja has significantly enhanced the growth, cane juice quality, and yield attributes of the crop.

Development of Vasant Urja incorporated Urea-briquettes for enhanced fertilizer delivery and induced drought tolerance in Okra has resulted significant results. The data indicated that with the chitosan fortified briquettes nitrogen fertilizers to 20% and irrigation to 40%. The application has been submitted for Patent approval.

Collaborative research with MPKV Rahuri

A field trial on onion in association with Onion and Grape Research station, Pimpalgaon Basawant was conducted on Vasant Urja for sustainable onion bulb yield and quality enhancement was conducted at VSI Manjari farm. The first year result indicated that 100 ppm Vasant Urja resulted in 10.6 t/ha additional yield.

A trial in association with Rice Research Station Vadgaon Maval MPKV Rahuri was initiated for enhancement of aroma in local rice varieties. Green house studies indicated that 100 ppm Vasant Urja showed higher grain numbers and '1000' seeds weight. Biochemical analysis of different physiological parameters are in progress.

The morphological and yield attributes viz. leaf length, leaf width, panicle length, no. of panicles, weight of '1000' grains showed significant differences (CD 5 %) within the cultivars where, foliar application



of GIC 100 ppm showed better results. The significant grain yield was recorded at GIC 100 ppms in Phule Samrudhi (PS), Indrayani with 9.11% and 10.48% increase over control respectively. In 1832 and 1808, 17.08% and 8.07% increase in yield over control was observed @100 ppm Vasant Urja (Fig. 4).



Fig.4 Effect of Vasant Urja on panicle length and grain yield in rice

A trial in association with ZARS, Kolhapur has been planted on finger millet conducted for use of Vasant Urja for enhancing the productivity and quality.

Collaborative research with CSK Himachal Pradesh Krishi Vishvavidyalaya (CSKHPKV), Palampur, Himachal Pradesh

Comparative study has been conducted on the use of non-irradiated, Electron beam irradiated and Gamma irradiated Vasant Urja Biostimulator on Tall fescue (a forage crop) for fodder quality improvement.

Significant differences have been observed in seed treatment, foliar sprays, and seed treatment + Foliar sprays at different concentrations. Morphological parameters and biochemical parameters were found to be influenced by the treatment of chitosan derivatives. The results confirmed that the seed treatment + foliar spray (50 ppm) of gamma irradiated chitosan was effective in increasing the tall fescue productivity compared to that of electron beam irradiated and non-irradiated chitosan.

Collaborative research with Maharashtra Pollution Control Board, Mumbai

Under the project on Development of a thermostable microwave reactor system for chitosan nanoparticles/ nano-conjugates design and development of thermostatic microwave reactor system by them has been completed. The microwave unit is expected to be installed in May 2024.

Domestic microwave based protocols for the synthesis of nanocomposites of chitosan, silver and copper were optimized. Chitosan-Silver and Chitosan-

Copper nanocomposites have been synthesized. ZnO 12, a nanoparticles and its composites with chitosan are synthesized using laboratory/ domestic microwave oven. The efficacy of silver, copper and chitosan Bt-protein nanoconjugate synthesized has been reported in different field trials.

MOLECULAR BIOLOGY AND GENETIC ENGINEERING

The section is working in major objectives of biotechnological interventions in sugarcane improvement through transgenic technology, induced mutagenesis. The section is recognized by DBT as Accredited Test Laboratory (ATL) for virus indexing and genetic fidelity tests of tissue culture raised plants under NCS-TCP Project. Staff was involved in internships/ short term research project work to graduate; post graduates students and guidance to research scholars working for their Ph.D. studies. The brief work done on various projects are given below.

Ectopic expression of Glycine betaine genes for enhanced water deficit stress tolerance in sugarcane

The aim of the project is to improve drought tolerance through overexpression of glycine betaine accumulating and Betaine aldehyde dehydrogenase (BADH=bet B) genes (*Choline dehydrogenase*-(CDH=bet A) in sugarcane commercial varieties Co 86032. For the confirmation of transgenic event fusion primers were designed to amplify the region between : 1) Promotor and Gene (Ubi-Fwd and BetA-Rev : 802 Bp), 2) Gene + Terminator (Bet A/B and NosTer : 726 Bp), 3) Selectable marker-Hygromycin (HygR-605 Bp). The required bands were not detected in earlier transgenic lines. Fresh experimentation by *Agrobacterium* mediated method is initiated and few putative transgenic lines able to survive on Hygromycin selection of 20 ppm are obtained. The lines are continued with Hygromycin selection and further will be evaluated for presence of gene.

Metabolite engineering of lutein biosynthetic pathway of indigenous marigold by tissue-specific over expression of AtWRKY35 in the knockout background

The project aims to increase health beneficial bio



(149.93 t/ha) and CCS (21.05 t/ha) yields, followed by foliar application of multimacro and micronutrients at 60 and 90 DAP.

Varietal response to plant growth regulators and its effect on growth, yield and quality of sugarcane (2nd plant)

The experiment was carried out to understand the effect of different growth regulators on sugarcane productivity, the results revealed that variety VSI 08005 had the highest cane (141.27 t/ha) and CCS (20.41 t/ha) yield and cost benefit ratio (1:2.03). Among the different growth regulators, spraying of IBA @ 50 ppm at 60 DAP + Triacantanol @ 2 ppm at 90 & 120 DAP + GA GA₃ @ 35 ppm with 6 BA @ 50 ppm at 90 & 120 DAP treatment ensures the higher cane and CCS yield (153.29 t/ha & 22.66 t/ha) as well as the cost benefit ratio (1:2.16).

Varietal response to plant growth regulators and its effect on growth, yield and quality of sugarcane (1st ratoon)

To determine the effect of different PGRs on growth performance of sugarcane ratoon and the results revealed that variety VSI 08005 produced the highest ratoon (124.07 t/ha) and CCS (17.91 t/ha) yields. Among the various growth regulators, spraying of IBA @ 50 ppm at 60 DARI + Triacantanol @ 2 ppm at 90 & 120 DARI+ GA GA₃ @ 35 ppm with 6 BA @ 50 ppm at 90 & 120 DARI treatment gave the highest cane and CCS yield (124.26 t/ha & 18.64 t/ha).

Agronomic evaluation of promising sugarcane mutant (3rd plant)

A trial was conducted to assess the agronomic performance of sugarcane mutants developed by VSI. Results showed that mutant 8711 from CoM 0265 had the highest cane yield (132.50 t/ha) and cane yield (17.12 t/ha), while, mutant 2543 from VSI 434 had superior brix (21.430), sucrose (19.81%), and CCS (14.18%). In contrast, mutants 8457 and 8733 were found to be on par with the superior mutant.

Agronomic evaluation of promising sugarcane mutant (2nd ratoon)

A trial was set up to evaluate the ratoon performance among multiple sugarcane mutants (developed by VSI), and the findings revealed that mutant 8711 produced the highest ratoon cane yield (123.55 t/ha) and CCS yield (17.70 t/ha). Mutants 8457

and 8733, are comparable or superior in terms of cane and CCS yield. In terms of quality metrics, brix (22.670), sucrose (21.15%), and CCS (15.20%) were greater in mutant 8711.

Performance of Sugarbeet varieties in Maharashtra (1st crop)

Sugarbeet is a supplemental crop to sugarcane and an excellent source of raw material for ethanol production. Sugarbeet is a temperate season crop that may be cultivated in tropical climates with adequate agronomic practices. So, in this context, an experiment was conducted to examine Sugarbeet germplasm in Maharashtra, and the result revealed that variety LKC-2020 gave the highest beet yield (65.26 t/ha). Whereas, quality metrics, LKC-2006 had the highest brix (21.130), LKC-HB had the highest sucrose (17.48%), and L-33 had the highest purity percentage (91.87%).

Agronomic performance of elite sugarcane genotypes (Plant crop)

The field trial was carried out to evaluate the performance of various elite sugarcane genotypes at varying fertilizer levels. The plant crop data showed that applying 25% more fertilizer over RDF resulted in the highest cane yield (108.36 t/ha) and CCS production (16.01 t/ha), although the difference was not significant. In terms of genotypes, genotype Co 17002 showed the highest germination (66.75%) and number of millable cane at harvest (83.50 thousand/ha). However, genotype Co 17004 produced much more cane yield (126.71 t/ha), while, genotype Co 17001 produced the higher CCS yield (19.63 t/ha). Co 17005 had superior brix quality, while, genotypes CoC 671 had the highest sucrose (21.91%) and CCS (15.82%) levels. The highest B:C ratio was recorded in genotypes 17004 (1.73).

Evaluation of sugarcane varieties for drought tolerance (2nd plant crop)

The field experiment was conducted to evaluate the existing sugarcane varieties for drought tolerance at various irrigation levels (0.3 and 1.0 IW/CPE ratio). The results revealed that irrigating the crop at a 1.0 IW/CPE ratio ensures maximum cane production (135.58 t/ha) and CCS yield (20.40 t/ha). In terms of varieties, MS 10001 produced higher cane (142.23 t/ha) and CCS (21.70 t/ha) yield, but it did not

differ significantly from Co 12009 or CoVSI 12121. The juice quality was found to be higher in Co 11015.

Evaluation of new herbicide molecule for weed management in sugarcane (1st Plant)

The field experiment was conducted to study the performance of new herbicide molecules and results revealed that, Pre-emergence application of Clomazone 22.5% + Metribuzine 21% WP (ready mix) @2.5 kg/ha followed by one inter-cultivation at 60 DAP (partial earthing up) resulted in significantly higher number of tillers and NMC count (102.00 & 91.17 thousand/ha). In contrast, post-emergence application of Halosulfuron methyl + Metribuzine (ready mix) @ 1 L/ha resulted in the maximum cane yield (121.66 tons/ha).

Sugarbeet seed production program in collaboration with USDA-ARS

Vasantdada Sugar Institute working on project on Assessment of Seed Production Potential of sugarbeet lines in tropical conditions. the project is currently underway at VSI, IISR Lucknow and CPRI, Shimla with the collaboration of USDA scientist. Sugarbeet germplasm acquired from the USDA was cultivated on an open field in Shimla to initiated bolting and flowering.



Fig. 1: Seed Production Project at CPRI, Shimla

SOILSCIENCE SECTION

The soil science section is mainly focuses on applied research on recent threats like declining soil fertility due to imbalanced use of chemical fertilizer and inadequate use of organic manure, increasing the

area under salt affected soils, impact of climate change on sugarcane productivity. The section is also engaged in the activities such as extension, training, consultancy and formulation and production of agro inputs. The section deals with the research on development of nutrient management package for planting of sugarcane seedling, use of advanced technologies like drone for foliar application of VSI inputs, initiated the work on use of artificial intelligence for identifying sugarcane maturity. The section is also involved in collaborative research work with TIH foundation, IIT Mumbai for nutrient sensor. The research team is also involved in the development of low cost technology for preparation of biochar, use of spentwash powder as a potash fertilizer, formulation of nanom micronutrient. One of the recent accomplishments of the section is the formulation and commercialization of chelated micronutrient for foliar application on sugarcane and all other crops.

The section has an advanced soil, plant, water and fertilizer testing laboratory with state of art, modern equipment and analytical tools. The section is providing soil testing training and services to the sugar mill staff and farmers. Additionally, the team also provides guidance concerning technical know-how for soil testing facilities; GPS-GIS based soil fertility mapping, nutrient enrichment of bio-compost and various practices for soil fertility management. The section supplies the inputs namely macro and micronutrient for foliar application, water-soluble solid microsols and VSI-humic for soil application in sugarcane farming.

Recommendation approved in joint Agresco 2024

Application of recommended dose of fertilizer (300:140:140 N:P₂O₅:K₂O kg ha⁻¹) along with FYM 20 tha⁻¹ and 25 kg ha⁻¹ micronutrient grade I or 25 kg ha⁻¹ ferrous sulphate and 20 kg ha⁻¹ zinc sulphate (incubated for 15 days 1:10 proportion in FYM before application in soil) and drenching of phosphate solubilizing bacteria @ 2.5 L ha⁻¹ and potash mobilizing bacteria @ 2.5 L ha⁻¹ in suru season (Co 86032) for higher cane, CCS yield and monetary returns is recommended as per the following schedule for calcareous soils of Western Maharashtra.



Split application of fertilizer nutrients

Sr. No.	Fertilizer added (kg ha ⁻¹)	At planting	45 days after planting	90 days after planting	120 days after planting	Total
1.	62% N -Urea	7	260	65	71	403
2.	20% N - Ammonium sulphate	-	-	-	250	250
3.	100% P ₂ O ₅ - Diammonium Phosphate	150	-	-	150	300
4.	20 % K ₂ O - Sulphate of potash	29	-	-	29	58
5.	80% K ₂ O - Muriate of potash	93	-	-	93	186
6.	Micronutrient grade I or Ferrous sulphate and Zinc sulphate	25 or 25 20	-	-	-	25 or 25 20
7.	Phosphate solubilizing bacteria - Drenching	2.5 lit	-	-	-	2.5
8.	Potash mobilizing bacteria - Drenching	2.5 lit	-	-	-	2.5

Effect of different organic inputs and Jivamrut application on sugarcane yield and soil fertility (Plant cane)

The field experiment was conducted to study the effect of different organic inputs and jivamrut application on sugarcane yield and soil fertility. The present investigation indicated that there was numerically increase in cane yield due to application of jivamrut and groundnut as an intercrop as compared to control but statistically non significant.

Development of package of practices for organic sugarcane (Ratoon II)

Application of vermicompost @ 5 t/ha at planting and 120 days after planting, zeolite @100 kg/ha, seaweed @ 12.5kg/ha, potash from incineration ash along with foliar application of fulvic acid @ 2 lit/ha at 60 days after planting increased cane yield by 22.02% over control.

Integrated reclamation technology for sodic soil (Plant cane)

The application of biochar @ 2 tonn/ha⁻¹ with GRDF through Urea, Ammonium sulphate, diammonium phosphate, phosphoric acid, muriate of potash & sulphate of potash was found beneficial and economical for increasing higher cane and CCS yield.

Soil test based fertilizer recommendation of Aamboli and Nagpur farm of VSI

The pH ranged from slight to strongly acidic (4.36 to 6.55) and electrical conductivity was

0.02 to 0.21 dSm⁻¹). The available nitrogen is moderate; available phosphorus was low and available potassium content was high.

Nagpur farm

Eight representative pedons from VSI research farm, Nagpur from different land forms were studied for their morphological, physical and chemical properties. The soils were very shallow to very deep, well to moderately drained, dark to very dark grayish brown in colour, slightly to strongly alkaline (pH-7.7 to 9.5), calcareous in nature, low to medium in organic carbon (0.09 to 0.78%) and very high in CEC (30.8 to 56.8 C mol (p+)/kg. Soil texture varied from clay loam to clay with clay content ranging from 35 to 64%. Bulk density varied from 1.3 to 1.6 Mg M⁻³ and generally increased with depth. The dominance of exchangeable cations were in the order *viz.* Ca²⁺>Mg²⁺>Na⁺>K⁺. Soils were low in available nitrogen (N), low to moderate in available phosphorus (P) and high in available potassium (K).

Effect of foliar application of nanosilica along with oligochitosan on growth, yield and quality of sugarcane

The results revealed that application of sett treatment of 1% nanosilica, with oligochitosan along with recommended dose of fertilizer and foliar application of 1% nanosilica with oligochitosan at 60 and 90 days after planting was found beneficial and economical for increases cane yield by 19.36% and CCS yield by 17.7% over control.

Optimization of dose of VSI inputs (Vasanturja, Plant health, Multimacronutrient and Multi-micronutrient) for sugarcane crop using drone technology

The present investigation indicated that Vasanturja, plant health, multimacronutrient and multi-micronutrient at 1 m height from crop was found comparable with hand spray of Vasanturja, plant health, multimacronutrient and multimicronutrient.

Optimization of dose of fermented organic manure and its response with inorganic nutrients on sugarcane yield and soil fertility

The result concluded that the application of recommended dose of fertilizer along with fermented organic manure @ 15 t/ha increases the cane yield by 11.72% and sugar yield by 15.91% over control (RDF).

Effect of different sources of potash (Mollases powder) on soil properties, growth, yield and quality on sugarcane

The application of GRDF through Urea, DAP and potash derived from spentwash powder was found statistically on par with the GRDF through Urea, DAP, muriate of potash and different combinations of potash derived from spentwash powder and muriate of potash. The application of GRDF through Urea, DAP, and potash derived from spentwash powder increased the cane yield by 4.8% and sugar yield by 8.7% over control (Urea, DAP, MOP).

Effect of Warkem organics on growth, yield and quality of sugarcane (Ratoon)

The present investigation indicated that the application of 75% general recommended dose of fertilizer along with 100% WARKEM organics increased the cane yield by 20.07 % and sugar yield by 21.09 %.

Effect of POLY4 on nutrient use efficiency, yield and quality of sugarcane (Plant cane) (Sponsored by Angloamerican company)

The data showed that soil application of POLY4 and muriate of potash in 50:50 proportionate increased cane yield by 15.39% and sugar yield by 15.81%.

AGRICULTURAL MICROBIOLOGY

The section is widely recognized as centre of research in Agricultural Microbiology with respect to basic, applied & strategic research extensively for the development of different agricultural beneficial liquid biofertilizers, bio-pesticides & bio-fungicides and decomposing culture for solid and liquid waste management. Over the year, about twelve lakh twenty-five thousand liters of different microbial biofertilizers and biocontrol agents have been reached to the farmer's field from laboratory. The research findings are beneficial to cane growers and sugar industry. After the field evaluation recommendation from the Joint Agresco, the efficient microbial strains developed in the section are mass produced. The section is associated with ICAR and Maharashtra State Agricultural University.

The section has undertaken the research projects on microbial PGPR, Mn & B solubilizing bacteria, decomposing enzymes, bio-weedicide, pesticide degrading bacteria and microbial reclamation of sodic soil.

The section also deals with rearing of earthworms and production of vermicompost, provides consultancy for establishment of mass production of liquid bio-fertilizers unit, composting of agro industrial waste & its enrichment and vermicompost to the sugar mills in Maharashtra and adjoining states. Apart from the development of microbial products, section has also well equipped in-house Quality Control & Microbial analysis laboratory, where quality control, analysis of bio-fertilizers, vermicompost, compost, sugar and enriched compost samples from outside is carried out. The section is recognized as advanced research centre and continues to be centre for mass production & supply of different liquid biofertilizers and biocontrol agents of high quality standards as per Fertilizer Control Order (FCO) & Central Insecticide Board (CIB), Faridabad. The liquid biofertilizers & biocontrol agents are registered with different trade names and received organic certification from Ecocert. Technical advice to the farmers on liquid biofertilizers, biocontrol agents & vermicompost, is transferred through popular articles in newspapers, magazine and by delivering talk on Radio and Television. The section has a strong liaison with sugar industry and individual farmers.



Research highlights

A. Laboratory scale

Isolation, identification and screening of plant growth promoting rhizobacteria for enhancing cane and sugar yield of sugarcane crop

Total 10 isolates isolated from soil samples collected from sugarcane rhizosphere showed compatibility towards each other. Growth hormone, IAA & GA₃ production by consortia showed higher concentrations of GA₃ (117.31 µg/mL) when extracted with solvent extraction method and (891.73 µg/mL) of IAA observed in filtration method.

The stability study of growth hormone, IAA & GA₃ obtained up to eight months at 40°C. Initial IAA concentration by filtration method was 1976.86 µg/ml after four months it was recorded 1657.69 µg/mL and at eight months 1477.69 µg/mL. The concentration reduction rate was 16-25% for four months.

Initial GA₃ concentration by solvent extraction method was 250.19 µg/mL after four months it was 186.18 µg/mL and at eight months, it was 144.80 µg/mL. The concentration reduction rate was 25-42% for four months. Wheat germination study was carried out in glass Petri plate and observed that the highest germination percentage 81.82% and 84.85% by IAA 30 ppm and 50 ppm concentration respectively, where as the highest germination percentage of 78.79% and 57.58% by GA₃ 25 ppm and 55 ppm concentration.

Isolation, identification and characterization of Manganese (Mn) and Boron (B) solubilizing bacteria from soil

Isolated 10 Mn solubilizing and 4 Boron solubilizing bacteria from soil samples and Mn isolates were tested for manganese solubilizing index, the highest zone of solubilization was observed in isolate 6 on 50mM and isolate 9 on 100mM MnO₂ concentration i.e. 3.45cm and 2.7cm respectively. Manganese solubilizing bacteria were optimized for pH and Temperature. All isolates showed the maximum growth at pH 5 to 6 and temperature 25°C to 30°C. These isolates were checked for its compatibility with each other. All isolates showed compatibility except isolate 10.

Newly isolated boron isolate BA1 and BA3 were Gram negative. BA1 was negative for all sugars.

BA3 was lactose negative and acid and gas positive for Glucose, Sucrose, Mannitol, Fructose and Maltose. All the four isolates were tested for boron tolerance assay at 50mM, 100mM, 150mM & 200mM Boric acid concentration and showed growth at 50mM Boric acid and the highest growth was observed by isolate B2. Further, study is in progress.

Isolation, screening and purification of waste decomposing enzyme from bacteria for decomposition of organic waste

The quantitative estimation of amylase, protease, lipase and cellulase enzymes of ten bacterial isolates was carried out. Cellulase activity from 0.51 ug/ml to 0.63 ug/mL, amylase activity from 0.41 ug/mL to 0.54 ug/ml, protease activity from 2.17 ug/mL to 3.10 ug/ml and lipase activity from 1.65 ug/mL to 2.05 ug/mL at 15 days of incubation were recorded respectively. The purification method of amylase, protease, lipase and cellulase enzymes by column was standardized. It was revealed that the amylase, protease, lipase and cellulase enzymes produced by these bacteria can be further, purified by column in large level. Further studies for its efficiency are in progress.

Isolation, identification and characterization of pesticide degrading bacteria for enhancing the soil fertility

The 20 soil samples were collected at 8,15, 21 and 30 days after pesticide application from four different fields of Manjari and Naigaon Farm, VSI. Total 30 bacterial isolates were isolated out of which eight isolates were selected on the basis of maximum pesticide degradation. The five isolates were Gram negative rods and 3 isolates were Gram positive rods. All 8 isolates were non lactose fermenting bacteria and producing catalase & oxidase enzyme. It was observed that in pesticide applied field, bacterial population was the highest whereas, fungi and actinomycetes population was not observed. Further, studies on the efficiency of isolates are in progress.

Standardization of simple and cost effective techniques for mass multiplication of sugarcane bio-agents-(AICRP project)

The study was conducted to develop an EPN formulation with increased shelf life and storage potential. The initial count of EPN 3x10⁸ IJ/mL was

used for shelf-life study and count of EPN was checked for every month in modified formulation at room temperature. The modified formulation containing entomopathogenic nematode showing a shelf life up to 11 months with survival of nematodes (2.5×10^8 IJ/mL) at room temperature. Further, study of shelf life is in progress.

B. Field scale

Effect of application of Jeevamrut containing natural agricultural beneficial microorganisms on yield and quality of sugarcane (Pooled)

Three years field research trial was carried out for evaluation of effect of application of Jeevamrut containing natural eco-friendly beneficial microorganisms *viz.* Nitrogen fixers, Phosphate solubilizers, Potash mobilizing bacteria, Sulphur oxidizing bacteria, Silicon solubilizing bacteria, Iron and Zinc solubilizing bacteria, revealed that the highest cane yield (126.13 tha^{-1}), CCS yield (19.40 tha^{-1}), Cost Benefit ratio (1: 2.80), nutrient concentration (N-1.99%, P-0.26% & K-1.30%) and microbial count at 106 dilution (30.5 CFU/gm of soil) was found where application of Jeevamrut at sett treatment and drenching of Jeevamrut at 30, 60, 90 and 120 DAP & 100% RDF over control where without Jeevamrut & NPK i.e. Cane yield (67.62 tha^{-1}), CCS yield (11.48 tha^{-1}) Cost Benefit ratio (1:1.52), nutrient concentration (N-1.20 %, P-0.09 % & K-0.49 %) and microbial count at 106 dilution (1.3 CFU/gm of soil) respectively.

Recommendation: Sugarcane sett treatment at planting and drenching at 30, 60, 90 & 120 days after planting with 3-7 days old microbial slurry (water-1lit, Desi cowdung-50g, organic Jaggary-10g, homemade chana flour-5g, butter milk-10 mL, biofertilizer applied field soil-5g and wooden cold pressed groundnut oil - 1mL) having beneficial bacteria (*Azotobacter Chroococcum*, *Bacillus polymyxa*, *Pseudomonas striata*, *Fraturea aurentia*, *B. megateium*, *Thiobacillus thioxidans*, *T.feroxidance*, *Lactobacillus plantarum*, *Rhodopseudomonas acidophila* and *R. palustris*) @ 500 lit. ha^{-1} with 8 days old 5 lit. cow urine to suru sugarcane with recommended dose of fertilizer ($250:115:115 \text{ kg N:P}_2\text{O}_5:\text{K}_2\text{O ha}^{-1}$ and FYM 20 tha^{-1}) is recommended in medium deep black soils for higher cane & sugar yield and improving soil fertility.

Studies on use of Biotoxins as bioherbicide for control of weeds (pre-emergence & post emergence) in sugarcane 2nd plant cane and ratoon

The field study conducted, on application of bioherbicide on pre & post emerged weeds *viz.* Carrot grass, Spiny pigweed, Common purslane, Asthma plan were control within 48 hrs. The seed borne weeds can be controlled by bioherbicide and visual phytotoxicity in sugarcane crop was not observed. The vegetatively growing weeds (Shippi, Nutgrass, Bermuda grass, & Little love grass) regenerated when plots were irrigated at seventh day after application of bioherbicide.

In this trial, the significantly the highest cane yield (101.20 tha^{-1}) and CCS yield (15.78 tha^{-1}) was found in weed free plot followed by Pre-emergence + Post-emergence application of bioherbicide at 5th and 9th DAP was done followed by cane yield (101.20 tha^{-1}) and CCS yield (15.43 tha^{-1}) recorded.

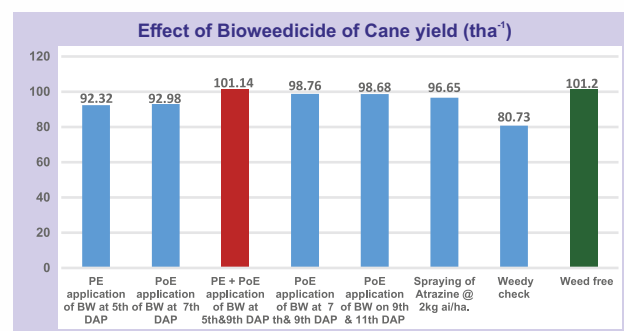

Effect of bioherbicide on can yeild (tha⁻¹)

Biological remediation of sodic soils through integrated approach through application of inorganic & organic fertilizers

A field research trial was carried out for evaluation of effect of application of consortium of halophilic and halotolerant bacteria. It was revealed that the highest cane yield (136.78 tha^{-1}) and CCS yield (27.02 tha^{-1}) was found in application of consortium of halophilic and halotolerant bacteria @ 12.5 tha^{-1} at planting and 12.5 tha^{-1} at earthing up with 100 % GRDF was done followed by cane yield (128.19 tha^{-1}) and CCS yield (25.28 tha^{-1}) by application of consortium of halophilic and halotolerant bacteria @ 25 tha^{-1} at planting with 100% GRDF over control (100% GRDF without consortium of halophilic and halotolerant bacteria) for higher cane yield (87.79 tha^{-1}) and CCS yield (16.34 tha^{-1}).

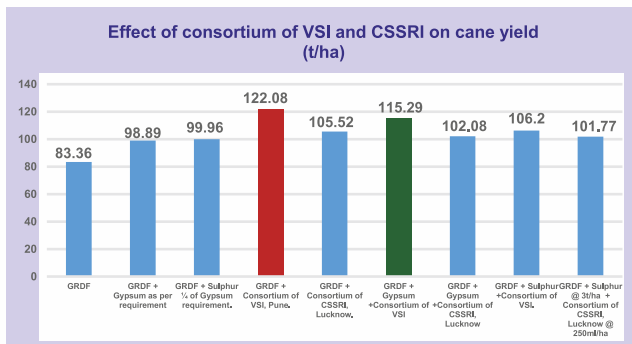

Effect of consortium of VSI and CSSRI of cane yield (tha^{-1})

Biological remediation of sodic soils by application of bacterial consortium (VSI, Pune and CSSRI, Lucknow) and soil amendments

A field research trial was carried out for evaluation of effect of application of bacterial consortium (VSI, Pune and CSSRI, Lucknow) and soil amendments. It was revealed that the highest cane yield (122.08 tha^{-1}) and CCS yield (23.96 tha^{-1}) was found in application of GRDF+ Gypsum (2.0 tonnes + Consortium of VSI @ 25 tha^{-1} followed by cane yield (115.29 tha^{-1}) and CCS yield (23.09 tha^{-1}) by application of consortium of halophilic and halo tolerant bacteria @ 25 lit/ha at planting with 100% GRDF over control ((100% GRDF without consortium of halophilic and halotolerant bacteria) for cane yield (98.89 tha^{-1}) and CCS yield (18.97 tha^{-1}).

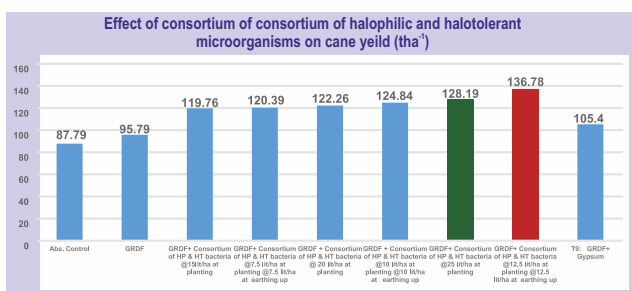

Effect of consortium of consortium of halophilic and halotolerant microorganisms on cane yield (tha^{-1})

Biological remediation of sodic soils through integrated approach through application of inorganic & organic fertilizers

A field research trial to evaluate effect of consortium of halophilic and halotolerant microorganisms on reclamation of inorganic and organic fertilizers in sugarcane ratoon. It was revealed that the highest cane yield (69.06 tha^{-1}) and CCS yield (12.75 tha^{-1}) was found in application of GRDF+

Consortium of halophilic and halotolerant microbes @ 12.5 tha^{-1} at ratooning and 12.5 tha^{-1} at earthing up over control (100% GRDF without consortium of halophilic and halotolerant bacteria) for cane yield (44.45 tha^{-1}) and CCS yield (7.60 tha^{-1}).

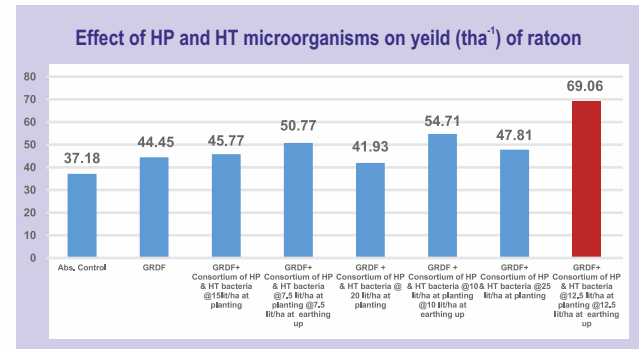

Effect of HP and HT microorganisms on yeild (tha^{-1}) of ratoon

Isolation, characterization, screening and development of special microbial culture for efficient treatment of sugar effluent

In large scale (100lits) continuous sugar ETP feeding experiment, the COD, BOD, sulphate, chlorides, TSS and TDS of initial sugar effluent was 38400 mg/l^{-1} , $14848.10 \text{ MgO}_2/\text{lit}$, $211.25 \text{ MgSO}_4/\text{lit}$, $179.94 \text{ MgCl}_2/\text{lit}$, 2240 mg/lit and 12160 mg/lit respectively. After 15 days of treatment with developed consortia, 5200 mg/lit , $1387.67 \text{ mgO}_2/\text{lit}$, $124.19 \text{ MgSO}_4/\text{lit}$, $59.98 \text{ MgCl}_2/\text{lit}$, 1260 mg/lit & 2040 mg/lit were recorded respectively.

The Skid Mounted ETP (2000lit) trial conducted at Malegaon SSK, Baramati, Pune to evaluate the efficiency of developed microbial consortia for sugar effluent. Initially, anaerobic treated effluent was used in aeration tank as a feed as the 60% load of chemical was reduced. It was recorded that 83-85% of COD reduction over to inlet. In another experiment, primary treated effluent as a feed was used in aeration tank. The COD, BOD, sulphate, chlorides, TSS and TDS of initial sugar effluent was 2000 mg/lit , $945.83 \text{ MgO}_2/\text{lit}$, $181.25 \text{ MgSO}_4/\text{lit}$, $334.90 \text{ MgCl}_2/\text{lit}$, 600 mg/lit and 2620 mg/lit respectively. After 12 days of treatment with developed consortia, it was 352 mg/lit , $142.33 \text{ MgO}_2/\text{lit}$, $12.90 \text{ MgSO}_4/\text{lit}$, $24.99 \text{ MgCl}_2/\text{lit}$, 220 mg/lit & 1380 mg/lit respectively. It was recorded that 88-90% of COD reduction and 80.89 - 86.03 % of BOD reduction over to inlet of the Malegaon SSK, Pune.

From laboratory scale and pilot scale trial (at Malegaon SSK, Baramati), it was concluded that the physicochemical parameters of sugar effluent after 12-15 days of treatment, can be reduced to 88-90% by treatment with developed consortia of isolates.

Evaluating efficacy of consortium of agricultural beneficial microorganisms as soil health and plant health products on yield and quality of sugarcane (AICRP)

A field research trial revealed that significantly the highest cane yield (124.23 tha^{-1}) and CCS yield (25.24 tha^{-1}) was found in 75% NPK + drenching of soil health product at planting, 30, 75 and 120 DAP + foliar application of plant health product at 60 DAP was done over control (100% RDF) for cane yield (116.87 tha^{-1}) and CCS yield (22.36 tha^{-1}).

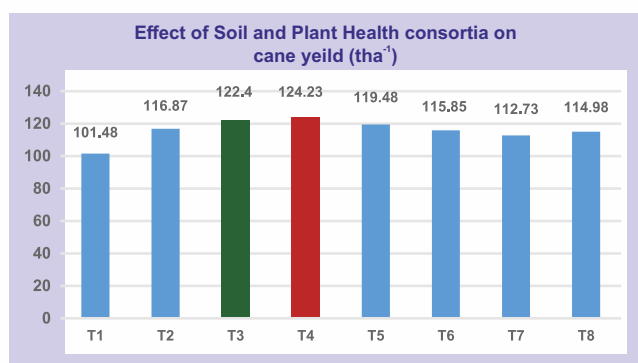

Effect of Soil and Plant Health consortia on cane yield (tha^{-1})

Effect of application of consortium of Iron & Zinc microbial bioinoculant on yield and quality of sugarcane in iron and zinc deficient soil (Multilocal trial-Bhimashankar SSK, Pune, SMSMP SSK, Akulj Solapur, SM Bhausaheb Thorat SSK, Sangamner)

The results of field research trial revealed that, at Bhimashankar SSK, Pune, significantly the highest cane yield (102.86 tha^{-1}) and CCS yield (11.50 tha^{-1}) was found in 100% $\text{FeSO}_4 @ 25\text{kg/ha}$ and $\text{ZnSO}_4 @ 20\text{kg/ha}$ + drenching of Iron & Zinc solubilizing microbial liquid bioinoculant @ 5.0lit/ha at planting followed by an application of 50% FeSO_4 (12.5kg/ha) and ZnSO_4 (10kg/ha) + drenching of Iron & Zinc solubilizing microbial liquid bioinoculant @ 5 lit/ha at planting (102.36 and 11.41 tha^{-1} cane & CCS yield) over control (100% RDF) (74.66 and 7.15 tha^{-1} cane & CCS yield).

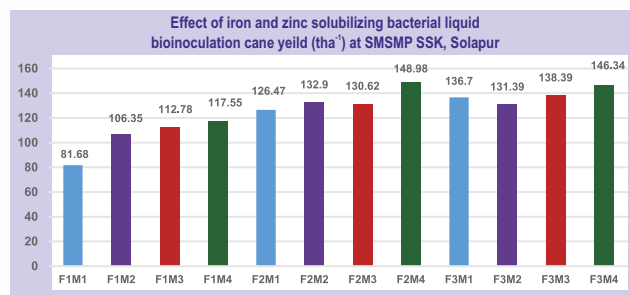

Effect of iron and zinc solubilizing bacterial liquid bioinoculation cane yield (tha^{-1}) at SMSMP SSK, Solapur

At SMSMP SSK, Akulj, Solapur, significantly the highest cane yield (148.98 tha^{-1}) and CCS yield (19.42 tha^{-1}) was found in 100% $\text{FeSO}_4 @ 25\text{kg/ha}$ and $\text{ZnSO}_4 @ 20\text{kg/ha}$ + drenching of Iron & Zinc solubilizing microbial liquid bioinoculant @ 5.0lit/ha at planting followed by an application of 50% FeSO_4 (12.5kg/ha) and ZnSO_4 (10kg/ha) + drenching of Iron & Zinc solubilizing microbial liquid bioinoculant @ 5 lit/ha at planting (146.34 and 20.08 tha^{-1} cane & CCS yield) recorded in over control (100% RDF) for cane yield (81.68 and 10.06 tha^{-1} Cane and CCS yield). The harvesting of trial SSBT is to be done in next season. So the data will be reported in next year.

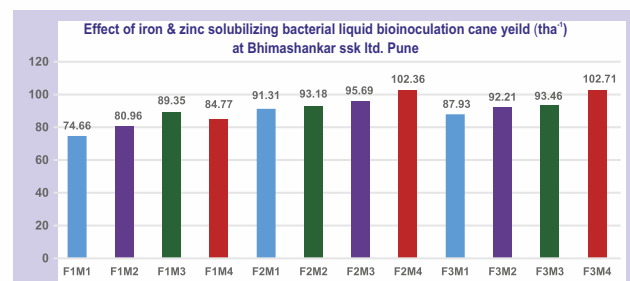

Effect of iron & zinc solubilizing bacterial liquid bioinoculation cane yield (tha^{-1}) at Bhimashankar SSK Ltd., Pune

Effect of application of KK PRO (Bio enriched organic manure) on yield and quality of suru sugarcane (Product Testing Trial)

A field research trials was carried out for evaluation of effect of application of KK PRO (Bio enriched organic manure) revealed that the highest cane yield (97.90 tha^{-1}) and CCS yield (13.70 tha^{-1}) followed by application of 100% RDF + KK PRO and 75% RDF + KK PRO was applied (93.71 tha^{-1}) and (13.05 tha^{-1}) over control (100% RDF) for cane yield (80.71 tha^{-1}) and CCS yield (11.63 tha^{-1}).



AGRICULTURAL ENGINEERING

Water management and Mechanization in sugarcane agriculture are two major activities of the section. The advanced technologies of micro irrigation system, fertigation and mechanization are developed by the section. The water management technologies and equipments developed by the section are recommended through Joint Agresco of Agricultural Universities of Maharashtra State. The drip irrigation system is effective to save irrigation water by 50% along with 35% increasing in cane yield and 40% saving in chemical fertilizers. The sugarcane planter developed by the section is patented and saves 50% cost on sugarcane planting. The earthing up equipment developed by the section is useful for efficient eartheniver up operation in sugarcane crop. In order to make ease of cane loading operation in trucks and tractor trolleys, electrical/engine power operated cane loader developed by the section is commercialized. The drip and sprinkler testing laboratory of the section is accredited by NABL and is helpful to the farming community for selection of better quality drip and sprinkler products.

Effect of different trash mulching techniques and irrigation practices on moisture conservation under surface and subsurface drip irrigation in sugarcane crop

The experiment on moisture conservation studies with sugarcane trash with and without shredding mulching under surface and subsurface drip irrigation in sugarcane conducted for plant cane revealed that among the irrigation practices subsurface and surface drip irrigation recorded significantly higher cane yield over surface irrigation. The highest cane yield (133.53 t/ha) was recorded in subsurface drip irrigation. Among the mulching techniques, trash mulching in every and alternate row with and without shredding recorded significantly higher cane yield over no trash mulching treatment. The highest cane yield (127.72 t/ha) was recorded in trash mulching in every row with shredding treatment. The highest water use efficiency (1.28 tha^{-1}cm) was recorded in trash mulching in every row with shredding under subsurface drip irrigation.

Effect of different mulches on moisture conservation and water productivity of sugarcane under surface drip irrigation

The experiment on moisture conservation studies with sugarcane trash with and without shredding, wheat straw and soybean straw mulching under surface drip irrigation in sugarcane conducted for plant cane revealed that among the irrigation levels of 1.0, 0.8 and 0.6 Etc, the Irrigation levels of 1.0 Etc and 0.8 Etc recorded significantly higher cane yield of 130.26 t/ha and 112.21 t/ha over 0.60 Etc irrigation level. Among the mulching practices, sugarcane trash mulching with shredding and without shredding, soybean straw mulching and wheat straw mulching recorded significantly higher cane yield as compared to no mulching treatment. The highest cane yield (118.58 t/ha) was recorded in sugarcane trash mulching with shredding. The highest water use efficiency (1.13 t/ha cm) was recorded in sugarcane trash mulching with and without shredding under 0.6 Etc irrigation levels.

Development of cane loader

The cane loader developed in joint collaboration of VSI and Mr. Mathew Zacharias, Mumbai is commercialized. The ease of cane loading with minimum man power is possible with this equipment.

Targeted yield plot

The targeted yield plot with sugarcane variety CoM 0265 was conducted by the section. The crop was harvested for seed purpose. The two eye budded seed sett availability of 244847 per acre was recorded in this plot.

AGRICULTURAL ECONOMICS

This section collects, compiles and analyzes the data on cost of cultivation, impact of adoption of innovative techniques of sugarcane cultivation. Season wise and variety wise area under sugarcane in the area of different sugar mills. Estimates percent seed area change in the operational area of sugar factories. In addition to this findings and information to the Government officials for future planning is provided. The section is also engaged in conducting lectures on Agricultural Economics and State Government schemes to farmers. Conducting lectures to different organization and academic

courses on low cost technologies in sugarcane cultivation and Cost of Cultivation, and also conduct statistics lecture to students of academic courses and gives statistical guidance to scientists of the institute. Also, involved in the activities of Information & Service Section to gave the information to visitors about VSI activities and products.

Trends in variety wise area and their impact on productivity and sugar recovery in Maharashtra

The majority of sugarcane area in the state was covered by VSI 08005, Co 86032, CoM 0265 and MS 10001 during last 5 years (2019 -20 to 2023-24). Other varieties in the state were in the range of 5.99 % (2021-22) to 9.49 % (2020-21). The variety Co 86032 and CoM 0265 have covered in the range of 72-82% area in state. Varietal percent area under both varieties was consistent at 72% in crushing season 2022-23 and 2023-24 (Fig. 1). While, in the last five crushing season the area under VSI 08005 and MS 10001 increased from 9.73 (2019-20) to 18.96 (2023-24). In crushing season 2022-23 (10.79%) varietal area under VSI 8005 increased by 1.13 % in 2023-24 (11.92%). Area under variety CoM 0265 decreased by 1.83% 2022-23 (26.48%) to 2023-24 (24.65%). At the same time area under Co 86032 increased by 2.06% (2022-23 (46.01) to 2023-24 (48.07)). The overall average cane yield of the state (98 t/ha) was recorded maximum in 2020-21, while, it was minimum (79 t/ha) in 2019-20. Maximum

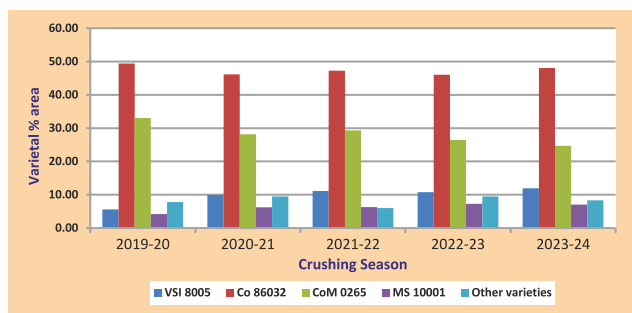

Fig 1: Trends in variety-wise area

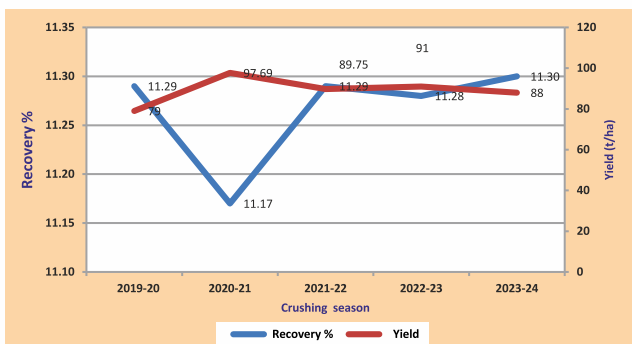

Fig 2: Trends in average yield and sugar recovery

similar sugar recovery 11.29 % was attained in 2019-20 and 2021-22 (Fig.2). In the year 2023-24 average sugarcane yield was expected to be decreased by 3* t/ha and increase in sugar recovery by 0.20* unit as compared to 2022-23 (*showed in Fig.2).

Trends in season wise planting area in Maharashtra

It is expected that proportion for sugarcane plantation in adsali, preseason, suru and ratoon crop is 10:30:20:40% respectively, while, actual trend during last five years (2019-20 to 2023-24) showed variation (Fig 3). The variation in planting season depends on climatic factors and rainfall distribution & price given by mills for sugarcane. Maximum adsali planting was observed 25% in 2019-20, preseason 26% (2021-22) and suru 23% in 2020-21. While, minimum adsali planting was done 18% (2022-23), preseason 12% (2019-20) and suru 7% (2019-20). It was also observed that maximum planting was done 67% in 2020-21 and minimum 45% in 2019-20. Ratoon crop was taken maximum in year 55% (2019-20) and minimum 33% (2020-21). Comparison 2023-24 shows that adsali was increased by 2.25 %, Preseason was increased by 4.35% and suru by 0.12% as compared to 2022-23. While, ratoon crop was decreased by 6.72% from this trend it was observed that planting increased by 6.72% in 2023-24 as compared to last year (Fig. 3). In view of the economics of cost of cultivation, it is advisable that the ratoon crop area remained at around 40-45%.

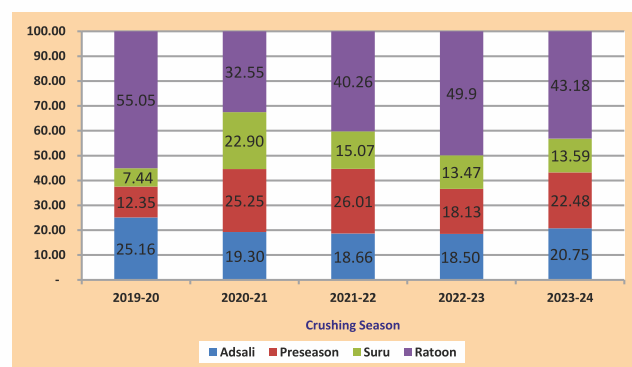

Fig 3: Changes in season wise plantation area in Maharashtra

CROP PROTECTION

ENTOMOLOGY

The section under taken screening of varieties/ genotypes in AICRP'S trials and promising genotypes developed under Institute's breeding programme against major insect pests. The section conducted survey of insect pest and trial on Integrated Pest



Management (IPM) of major sugarcane insect pest, mass multiplication of potential bioagent and its supply to sugar mills, Integrated approach to manage white grub and bio-efficacy of insecticides against *Spodoptera* spp. on sugarbeet for effective and timely management of pests.

Evaluation of zonal varieties/genotypes for their reaction against major insect pests

Advance varietal trial (I Plant)

Out of the fourteen varieties/ genotypes screened, Co 18013 was noticed less susceptible, Co 18003, Co 18061 and CoVSI 18121 were noticed moderately susceptible to early shoot borer while, others were highly susceptible to it. All varieties/ genotypes screened were found less susceptible to internode borer, mealybug and scale insect.

Advance varietal trial (II plant)

Pooled data showed that out of sixteen varieties/ genotypes screened, MS 17082, Co 17013 and CoN 17072 were noticed moderately susceptible to early shoot borer, while, other varieties/ genotypes were less susceptible to it. All varieties/ genotypes screened were less susceptible to internode borer. Co 17010 & CoN 17072 were moderately susceptible to mealybug.

Advance varietal trial (Ratoon)

Out of the sixteen varieties/ genotypes screened Co 17001, Co 17002, Co 17004, Co 17005, CoN 17072, Co 86032 (Std.) and CoVSI 18121 (Add.) were less susceptible to early shoot borer. All varieties/ genotypes screened were found less susceptible to internode borer. Co 17004 and Co 86032 (Std.) were found less susceptible to mealybug. All varieties/ genotypes were free from scale insect infestation.

Survey and surveillance of sugarcane insect pests

In the area of Vishwasrao Naik SSK Ltd. Dist. Sangli, the percent incidence of early shoot borer was maximum (0.33%) in Co 86032 planted on 1.06.2023. The incidence of internode borer was found maximum (40.00%) in Co 86032 planted on 17.11.2022. In the area of Shri Chhatrapati Shahu SSK Ltd. Kagal, Dist. Kolhapur the percent incidence of early shoot borer was maximum (0.24%) in Co 86032 planted on 11.08.2023. The incidence of internode borer was found maximum (26.67%) in Co 86032 planted on

14.08.2022. The incidence of mealybug was found maximum (26.67%) in Co 86032 planted on 17.08.2022.

Monitoring of insect pests and bioagents in sugarcane agro-ecosystem

The incidence of early shoot borer was maximum 8.82% in 19th standard meteorological week (10.05.2023). Internode borer percent incidence, per cent intensity and infestation index was recorded maximum 24%, 2.31% and 0.56, respectively in the 41st standard meteorological week (10.05.2023). The per cent incidence and intensity of mealybug was recorded maximum 54.00% & 5.07%, respectively in 45th SMW (8.11.2023). The per cent incidence of scale insect was found 16% in 51st SMW (22.12.2023)

Standardization of simple, cost effective techniques for mass multiplication of sugarcane bioagents

The plastic container was selected to support the nematode growth in liquid media, while maintaining oxygen level, which ultimately reduced the cost of production of EPN product by ₹ 281/ liter. As a part of this study, MLM B with increased shelf life and storage potential was done. The initial count of EPN 3×10^8 IJ/mL was used for shelf-life study and count of EPN was checked for monthly interval in modified formulation. The modified formulation containing entomopathogenic nematode showed a shelf life six months, because after six months the EPN count decreased from 3×10^8 IJ/mL to 2.1×10^8 IJ/mL upto 12 months at room temperature.

Integrated approach to manage white grubs in sugarcane

Per cent reduction in number of grub per clump over untreated control was recorded 20.93% and 23.25% in chemical module and organic module. Plant population per ha was recorded 18640, 15570 and 14474 in chemical module, organic module and untreated control, respectively. Sugarcane yield was recorded 23.11 and 18.86 t/ha in chemical module and organic module, while, it was the lowest 16.95 t/ha in untreated control.

Assessment of yield losses caused by borer pests of sugarcane under changing climate scenario

The germination per cent at 45 DAP was 68.33, 64.50, 56.67 and 52.83% in chemical control,

biological control, chemical + biological control and untreated control, respectively. The per cent incidence of early shoot borer was low and statistically at par 0.15, 0.00 and 0.09% in chemical control, biological control and chemical + biological control, respectively. While, it was statistically the highest (2.81%) in untreated control and per cent incidence, per cent intensity and infestation index of Internode borer was numerically the lowest 4.67, 0.35 and 0.04, respectively in chemical + biological control. While, in untreated control it was numerically the highest 8.67, 0.82 and 0.25, respectively.

Evaluation of zonal varieties /genotypes for their reaction against major insect pests in IVT

Out of twenty varieties/genotypes screened Co 86032 (Std.) was noticed moderately susceptible to early shoot borer, while other were less susceptible to it. Co 20007 and Co 20009 was moderately susceptible to internode borer, while, other varieties/ genotypes screened were less susceptible to it. Co 20001, Co 20005, Co 2009, Co 20012 and CoSnk 20102 were less susceptible to mealybug, while, other varieties/ genotypes screened were found moderately susceptible to it. All varieties/genotypes screened were noticed less susceptible to scale insect.

Evaluation of varieties/ genotypes for their reaction against major insect pests in Plant Breeding trials at VSI, Pune

Multi location trial (II Plant *Adsali*)

All sixteen varieties/genotype were found less susceptible to early shoot borer. Out of sixteen varieties /genotype screened PDN 15012 was moderately susceptible to internode borer, while, other varieties/genotype screened were less susceptible to internode borer. Out of sixteen varieties /genotype screened, VSI 82-1 was moderately susceptible to mealybug, while, other varieties /genotypes screened were found less susceptible to it. All varieties/ genotypes screened were free from scale insect infestation.

Multi location trial (II Plant *Preseason*)

All fourteen varieties/genotype were found less susceptible to early shoot borer. Out of fourteen varieties/genotypes screened CoM 18008 and MS 10001 (Std.) were found moderately susceptible to

internode borer, while, other varieties/ genotypes screened were found less susceptible to it. Out of fourteen varieties/genotypes screened VSI 82-1 CoN 18025, CoVSI 12-2 and CoC 671 (Std.) were found moderately susceptible to mealybug, while, other varieties/ genotypes screened were found less susceptible to it. Out of fourteen varieties/genotypes screened VSI 82-1 was found moderately susceptible to scale insect, while, other varieties/ genotypes screened were found less susceptible to it.

Multi location trial (II Plant *Suru*)

All varieties/genotype were found less susceptible to early shoot borer and scale insect. Out of sixteen varieties/genotypes screened PDN 15012, CoM 18016, CoM 18025, Co 09004 (Std.) and CoVSI 7-2 (Add) were found moderately susceptible to internode borer, while, other were less susceptible to it. Out of sixteen varieties/genotypes screened CoM 18016, CoM 18022, CoC 671 (Std), MS 10001 (Std.) and VSI 434 (Std.) were free from mealy bug infestation, while, other varieties/genotypes screened were found less or moderately Susceptible to it

Multi location trial (MLT *Ratoon Adsali*)

All varieties/ genotype screened were found less susceptible to early shoot borer and internode borer. All varieties/ genotype were free from mealy bug and scale insect infestation.

Multi location trial (MLT *Ratoon Preseason*)

All varieties/genotype screened were found less susceptible to early shoot borer, internode borer and scale insect. CoM 18005, CoM 18022, CoM 18025, CoC 671 (Std.) and VSI 08005 (Std.) were found less susceptible to mealybug. While, other varieties /genotypes screened were found moderately susceptible to it.

Multi location trial (MLT *Ratoon Suru*)

All varieties/ genotypes screened were found less susceptible to early shoot borer, except VSI 125-2 which was modularly susceptible to it. All varieties/ genotype screened were found less susceptible to internode borer. Co 09004 (Std.) and MS 10001 (Std.) were moderately susceptible to mealybug. While, other varieties/genotypes screened were found less susceptible to it. All varieties/ genotypes screened were free from scale insect infestation.



Mass multiplication of *Trichogramma chilonis* & *T. pretiosum* an egg parasite

During 2023-24 produced 2825cc *Corcyra* eggs, 1565 *Trichogramma chilonis* cards and 573 *Trichogramma pretiosum* cards. Supplied 981 *Trichogramma chilonis* cards and 281 *Trichogramma pretiosum* cards to VSI farm for management of borer insect pest. Supplied total 89 TC card, 49 TP card to farmer for management of borer and 166 cc *Corcyra* eggs to Bio-control lab as nucleus culture.

PLANT PATHOLOGY

Plant Pathology Section carryout research on diseases of sugarcane caused by biotic and abiotic factors related to survey, identification, causes, epidemiology and management. This section also associated in screening of newly developed sugarcane genotypes by VSI and genotypes under Zonal Varietal Trials against diseases of sugarcane under natural as well as artificial disease conditions. The basic work in Plant Pathology is also carried out by staff of the section as well as students on 'On Hand' training' deputed by various research institutions. Field experiments carried out at VSI & outside by the scientists of other disciplines are also observed by this section. This section is also providing different extension services including farmers & officers training programs, Television & Radio programs, popular publications, 'online' lectures and consultancy services to sugar mills and other institutes including NGO's.

Evaluation of varieties/genotypes under zonal testing for resistance to smut under artificial disease condition

Under AICRP (S), 33 genotypes including 2 susceptible checks (Co740 and Co7219) and 3 standard checks (Co 86032, CoC 671 and Co 94004) were screened artificially for evaluating their resistance to smut disease. Out of 33, 14 genotypes viz., Co 20001, Co 20002, Co 20005, Co 20006, Co 20012, CoSnk 20101, CoSnk 20102, CoSnk 20103, COT 20366, Co 18009, Co 18024, CoN 18071, CoN 18072 and CoVSI 18121 were reacted as resistant, 07 genotypes were moderately resistant, 07 genotypes were moderately susceptible, 2 genotypes were susceptible and 3 genotypes were highly susceptible to smut disease.

Screening of genotypes under AVT for yellow leaf disease

Yellow leaf disease (YLD) incited by sugarcane yellow leaf virus (ScLV) was observed on major commercially cultivated sugarcane varieties in many States of India. At VSI, on the basis of guidelines of AICRP on sugarcane, fourteen genotypes were observed in 8th, 10th and 12th month's age to see the natural incidence of YLD and were classified on the basis of severity grades. Out of 14 genotypes including standard checks, 10 genotypes found resistant to YLD, while, 4 genotypes viz., Co 18001, Co 18013, Co 18024 and Co 86032 were found moderately resistant to YLD under natural condition.

Screening of genotypes under AVT for brown rust disease under natural condition

Fourteen genotypes including standard checks under AVT were observed throughout the crop period for the occurrence of brown rust disease of sugarcane. Six observations on weekly intervals were recorded after the initiation of the disease. Out of 14 genotypes, CoN 18071 was found moderately resistant to brown rust disease, while, other 13 genotypes were found resistant to brown rust under natural condition.

Screening of genotypes under AVT for pokkah boeng study

Fourteen genotypes under AVT were observed throughout the crop period for the natural occurrence of pokkah boeng disease. The observations were recorded after every fortnight interval till the harvest of the crop. Out of 14, CoN 18071 genotype was found moderately susceptible, while, other 13 genotypes were found resistant to pokkah boeng.

Survey of sugarcane diseases in Maharashtra

- Whip smut disease caused by *Sporisorium scitaminae* was observed in severe form in Marathwada region of Maharashtra due to climate change, rise in temperature, negligence towards change of seed and poor management of ratoon crops. The incidence was more in ratoon crop of Co 86032, VSI 08005 and CoM 0265.
- Grassy shoot disease is noticed in all the commercially cultivated varieties of sugarcane in various stages of crop growth. Alike, smut, the incidence of grassy shoot disease was more in ratoon crops as compared with plant crop.

- The foliar diseases viz., rust pokkah boeng, yellow leaf, brown spot, mosaic and eye spot were also recorded on sugarcane. But the incidence of the diseases was low due to prolonged dry spell and thereby low humidity.
- The incidence of brown rust was moderate in Western and Central Maharashtra on CoM 0265 and Co 86032.
- The incidence of pokkah boeng disease was observed in all commercially cultivated varieties in Maharashtra. All the stages of the disease including 'Knife Cut' are noticed during the year.
- The incidence of yellow leaf disease of sugarcane was increasing and observed in all the regions on Co 86032, VSI 08005 and CoM 0265 up to 25%. The disease initiation was commonly observed after 8th to 10th month's age of the crop.
- Brown spot was commonly observed in CoM 0265. The incidence was also observed other varieties especially in Co 86032.

Management of yellow leaf disease through meristem culture.

Under this AICRP(S) project, tissue culture plantlets of two varieties viz., Co 86032 and VSI 08005 were transplanted in the field for the production of breeder seed and were observed throughout the year for the natural incidence of YLD. The incidence of YLD was observed in all treatments during the year. However, the incidence of YLD noticed late in plot where TC plantlets are used. This seems that there may be secondary spread of the disease due to some sucking pests.

Efficient delivery of the fungicides and other agro inputs to manage major fungal diseases in sugarcane

Under this AICRP(S) project, sett treatment with fungicide (Propiconazole) was carried out by using sett treatment device for the management of smut disease. The incidence of smut observed up to 18.75 %, in treatment where sets used from infected clump.

Development of inoculation techniques for pokkah boeng disease of sugarcane

Six different methods of inoculation were tested to study the development of pokkah boeng disease symptoms. The cotton swab and detached leaf assay techniques were found effective to develop the disease under artificial condition.

Screening of promising clones of sugarcane developed by VSI for resistance to smut

Seven clones developed at VSI were screened artificially for evaluating their resistance to smut disease. Out of 7 clones screened, two clones viz., VSI 125-1 and VSI 82-1 were reacted as resistant, VSI 114-1 was reacted as moderately resistant, VSI 94-1, VSI 56-2 and CoVSI 12-2 were reacted as moderately susceptible and remaining one clone i.e. VSI 135-3 was reacted as susceptible to smut disease.

Natural incidence of known and unknown diseases of sugarcane on promising varieties tested under zonal trials at VSI

Under AICRP (S), Plant Breeding Section of VSI tested 55 genotypes and 3 standard checks under four trials for assessing the performance at VSI condition. The bimonthly observations on natural incidence of diseases reveals that, grassy shoot was noted on twenty five genotypes, pokkah boeng noted on twenty-eight genotypes, mosaic noted on five genotypes, brown spot noted on two genotypes, brown rust noted on twenty-two genotypes and yellow leaf disease noted on five genotypes. However, twelve genotypes viz., Co 20005, Co 20010, CoM 20082, CoT 20366, Co 17010, Co 17013, CoN 17072, CoT 17366, CoVSI 56-2, CoVc 18061, Co 09004 and CoVSI 18121 were free from all the diseases throughout the year.

Occurrence of major diseases on promising genotypes of sugarcane at VSI

Sugarcane genotypes under eight trials viz., Multilocation Trial-I Plant-*Adsali* (ratoon), Multilocation Trial-II Plant- Preseason; Multilocation Trial- II Plant *Adsali*, Multilocation Trial II Plant *Suru*, Multilocation Trial-I Plant- Preseason (ratoon), Multilocation Trial I Plant *Suru*, Salinity Trial –I, Plant stress (ratoon) and Salinity Trial –I Plant control (ratoon) conducted by Breeding Section at VSI were observed for various diseases naturally occurring in the area. Observations reveals that the presence of whip smut on four genotypes, grassy shoot disease on twenty-two genotypes, brown spot on two genotypes, brown rust on six genotypes, pokkah boeng on thirty two genotypes, mosaic on four genotypes and YLD on five genotypes. Thirteen genotypes viz., VSI 82-1, VSI 125-2, VSI 12-2, Co 09004, VSI 15002, CoM 18016, CoM 18022, MS 10001, VSI 15068,



CoM 18005, 143-2, CoVSI 7-2, and CoVSI 18121 were observed free from diseases.

Efficacy of irradiated chitosan (Nano-particles) in combination with silver nano-particles and fungicide for the management of pokkah boeng disease

Under this VSI funded project, sett treatment and foliar applications of irradiated chitosan alone or in combination with silver nano-particles as well as fungicide were carried out. The analyzed data reveals that, there was significant difference in treated and untreated plots. The maximum disease control (62.76%) was obtained by 3 foliar sprays of silver nano-particles (100 ppm) + mancozeb (0.3%) + irradiated chitosan (50 ppm) at an interval of 15 days after initiation of disease.

Efficacy of irradiated chitosan (Nano-particles) in combination with *Trichoderma viride* and fungicide for the management of pokkah boeng, brown spot and rust diseases in sugarcane

Under this VSI funded project, foliar application of irradiated chitosan alone or in combination with *Trichoderma viride* as well as fungicide were tested. The analyzed data reveals that there was significant difference in treated and untreated plots. The maximum pokkah boeng disease control (65.60%) was obtained by 3 foliar sprays of irradiated chitosan at 60, 90 and 120 DAP + 3 foliar sprays of carbendazim (12%) and mancozeb (63%) at an interval of 15 days after initiation of disease. However, the incidence of brown spot and rust was not observed throughout the crop growth.

FARM MANAGEMENT

The Institute is in possession of eight farms at different locations in the State. The land at Manjari farm and part of Vasantdada farm are used for field experiments & demonstrations of Agriculture Sciences and Technology division. During the year various field experiments of AST division were taken on 23.36 ha. area and germplasm seed plot maintained on 0.94 ha. at Institute's farms. The lands of Naigaon, Lonarwadi and Patharwala farms are exclusively utilized for production of nucleus and the breeder seed of released, pre-released varieties and promising genotype of sugarcane. In totality 33.28 ha land was used for production of breeder seed at Institute farms for distribution to sugar mills and selected sugarcane growers for further production of foundation seed. The Amboli farm is particularly dedicated for the maintenance of sugarcane germplasm and development of new elite varieties through hybridization under plant breeding section. The land 53.84 ha has purchased at Nagpur for establishment of regional center for Vidarbha region of Maharashtra during the year 2023. The area utilized for different purposes on these farms are given in table 11.

Land development

Uncultivable land of Naigaon farm 11.55 ha is brought under mango plantation. Installation of 110 HP solar power work was completed. Deepening and expansion work of bandhara no. 1 and 3 was completed having water storage capacity 9.70 and 7.50 cr. Lit. The 25 ha land of Patharwala and Nagpur farm was leveled

Table 11: Area under sugarcane and rotational crops at different farms 2023-24 (ha)

Particular	Manjari	Vasantdada	Naigaon	Lonarwadi	Patharwala	Nagpur	Total
Plant cane Experiments	4.60	9.27	0.67	1.73	0.44	0.00	16.71
Germplasm maintenance	0.94	0.00	0.00	0.00	0.00	0.00	0.94
Ratoon cane Experiment	2.26	2.30	0.41	1.68	0.00	0.00	6.65
Nucleus seed	0.50	0.20	0.42	2.26	0.40	0.00	3.78
Breeder seed production	0.20	1.18	9.18	9.60	13.12	0.00	33.28
Commercial cane	0.00	0.00	6.0	1.03	0.00	0.00	7.03
Green manuring & Kharif crops	7.86	13.50	18	14.30	24.30	17.38	95.34
Rabi crops, Gram & Wheat	0.02	0.00	2.0	2.71	0.00	0.00	4.73
Summer soybean	0.00	0.00	0.00	0.00	3.00	0.00	3.00
Onion	0.02	0.02	0.02	0.00	0.00	0.00	0.06
International conference demo planting	2.34	0.00	0.00	0.00	0.00	0.00	2.34
Total	18.74	26.47	36.70	33.31	41.26	17.38	173.86

for sugarcane Breeder seed planting. Drip irrigation system was installed at Naigaon and Nagpur farm on an area of 11.55 and 3.00 ha respectively. The sub- surface drainage system work was completed on 14 ha. at Patharawala farm.

Nucleus seed production

Nucleus seed was preserved on 3.78 ha area which originates with consultation of plant breeder recommended variety for the region. Seed cane obtained from Nucleus seed cane is subjected to selection therapy (MHAT at 54°C for 2.5 hr at 95-99% RH). Total 1.75 million two budded setts of nucleus seed was produced and used for breeder seed production of Institute farm. The nucleus seed productions during 2023-24 are given in table 12.

Production of breeder seed

Sugarcane being a vegetative propagated crop, most of the diseases is transmitted through setts, which

affects the cane productivity adversely. Therefore, the production of disease free, healthy and genetically pure seeds through three tier sugarcane seed program is very important. The breeders' seed is distributed to sugar mills and cane growers for production of foundation and certified seed. This seed multiplication chain will be increase sugarcane productivity by 15 to 20%. Breeder seed production programme was taken on an area of 33.28 ha under National Food Security Mission, AICRP on seed project and from Institute's fund. Total 46.06 Lakh two eye budded setts were supplied to thirty three sugar mills in Maharashtra and outside States 1.51 Lakh setts to two mills. The seed distributed during 2023-24 are given in table 13.

This section has also distributed 0.39 Lakh one eye bud settlings to cane growers in the State as a breeder seeds. The settling distributed during 2023-24 are given in table 14.

Table 12: Farm wise, Vriety wise nucleus seed planted on VSI farm (area in (ha))

Farm	CoC	Co	CoM	PDN	VSI	MS	CoVSI	VSI	Total
	671	86032	0265	15012	434	10001	18121	08005	
Manjari Farm	0.00	0.15	0.10	0.00	0.00	0.05	0.10	0.10	0.50
Vasantdada Farm	0.00	0.05	0.05	0.00	0.00	0.03	0.05	0.02	0.20
Naigaon Farm	0.02	0.10	0.10	0.00	0.02	0.06	0.08	0.04	0.42
Lonarwadi Farm	0.05	0.50	0.50	0.00	0.05	0.10	0.50	0.56	2.26
Patherwala Farm	0.02	0.10	0.10	0.00	0.02	0.03	0.10	0.03	0.40
Total	0.09	0.90	0.85	0.00	0.09	0.27	0.83	0.75	3.78

Table 13: Zone wise breeders' seeds distribution during 2023-24 (in Lakh)

Zone	No. of mills	Co 86032	CoC 671	COM 0265	COVSI 03102	VSI 434	MS 10001	VSI 08005	CoVS 118121	Total
South zone	03	0.50	00	4.55	00	00	00	0.03	0.29	5.37
Central zone	07	3.21	0.02	7.06	0.21	0.02	0.17	1.03	7.28	19.00
Marathwada	01	3.92	0.01	2.29	00	0.03	3.92	6.96	0.71	17.84
Khandesh	00	0.24	00	0.16	00	00	00	0.16	0.59	1.15
Vidarbhb	02	00	00	00	00	00	00	00	2.70	2.70
Other state	02	00	00	00	00	00	0.10	0.90	0.51	1.51
Total	15	7.87	0.03	14.06	0.21	0.05	4.19	9.08	12.08	47.57



Table 14: Zone wise one eye budded settling distributed during 2023-24

(in Lakh)

Zone	No.of mills	Co 86032	CoC 671	COM 0265	COVSI 03102	VSI 434	MS 10001	VSI 08005	CoVSI 18121	Total
South zone	00	00	00	00	00	00	00	00	0.06	0.06
Central zone	00	0.03	00	00	00	00	00	00	0.12	0.15
Marathwada	00	0.11	00	00	00	00	00	00	0.07	0.18
Khandesh	00	00	00	00	00	00	00	00	00	00
Other state	00	00	00	00	00	00	00	00	00	00
Total	00	0.14	00	00	00	00	00	00	0.25	0.39

The rotational crops in Kharif Green manuring crop Sunnhemp, Dhaincha and Soybean was taken on 95.34 ha. In Rabi chickpea and wheat on 4.73 ha were taken in kharif, rabi and summer soybean on 3 ha area. The onion seed production was undertaken on 0.06 ha area under Directorate of Onion and Garlic Research Centre, Rajgurunagar, Pune (ICAR) for production of quality seed of elite onion lines in isolation at Institute farms. International Conference mega demonstration of different recommended cultivation practices was taken on 2.34 ha at Manjari farm.

Monthly Workshops

The Institute has continued the programme of monthly one day workshop on need based themes of sugarcane improvement and development. This activity has been started from July 2013. The themes of conducted workshops are given in following table 15.

Recommendations of the workshops finalized in working committee

Novel technologies of agriculture: beneficial microorganisms for sustainable sugarcane production
Recommendations of workshop for biofertilizers and

Table 15: Monthly Workshops

Date	Theme of the Workshop	No. of Participants	No. of sugar Mills
Aug. 26, 2023	Novel Technologies of Agriculture: Beneficial Microorganisms for Sustainable Sugarcane Production	64	37
Feb. 24, 2024	Advanced Management Practices for Sugarcane Crop	33	21
Mar. 23	Mechanical, biological and chemical management of pests in sugarcane	46	19

biocontrol agents for soil fertility & sugarcane productivity are given on next page table 16.

Advanced management practices for sugarcane crop

- Decomposing culture @ 2.5 litre ha⁻¹ along with 80 kg Urea & 100 kg SSP ha⁻¹ for decomposing of trash.
- The trash mulching reduces 3 to 4 irrigation rotations and improve the organic carbon level in the soil.
- Use micro irrigation system for efficient water management.
- Combined foliar application of Urea and Muriate of potash each @ 2 % concentration (2 kg urea + 2 kg muriate of potash in 100 litre of water) at 15 to 20 days interval during drought period.

- Foliar application of VSI multimacro & micronutrient each @ 2 litre in 200 litre water per acre at 60 days after planting/ ratooning & 3 litre in 300 litre water per acre at 90 days after planting/ ratooning
- Foliar application of 6 % kaolin anti-transparent between 60 to 150 days after planting/ratooning
- The shade loving flower crops like monster, dracaena, ferns, ginger, variegated ginger, aralia, croton etc. are ideal as intercrops in sugarcane crop.
- Drenching of liquid biopesticide (BVM) @ 2 liter / acre in 200 liter of water, liquid biofungicide @ 1 liter / acre in 200 liter water at the time of ratooning
- Drenching of soil health @ 1 liter /acre in 200 liter of water at the time of ratooning and at 30 days after ratooning.

Table 16: Recommendation of workshop : Novel Technologies of Agriculture: Beneficial Microorganisms for Sustainable Sugarcane Production

Name of Biofertilizers or Biocontrol agent	Method of application	Time of application
Liquid decomposing culture for trash mulching	50 kg Urea + 50kg Single super phosphate + spraying of DC culture @ 1 lit/acre in 200 lit water on trash (75 ml for 15 lit spray pump)	After harvesting of cane
Liquid Biopesticide (BVM) as a precautionary	Drenching of BVM @ 2 lit/acre in 200 lit water (150 ml for 15 lit spray pump)	At Planting/ ratooning
Liquid Biopesticide (EPN) if infestation of white grub seen.	Drenching of EPN @ 1 lit/acre in 200 lit water (75 ml for 15 lit spray pump)	At Planting/ ratooning
Liquid Biofungicide	Drenching of Biofungicide @ 1 lit/acre in 200 lit water (75 ml for 15 lit spray pump)	At Planting/ ratooning
Soil Health (SH)	Drenching of SH @ 1 lit/acre in 200 lit water (75 ml for 15 lit spray pump)	At Planting/ ratooning
Soil Health (SH)	Drenching of SH @ 1 lit/acre in 200 lit water (75 ml for 15 lit spray pump)	30 days after
Soil Health (SH)	Drenching of SH @ 1 lit/acre in 200 lit water (75 ml for 15 lit spray pump)	60 days after Planting / ratooning
Soil Health (SH)	Drenching of SH @ 1 lit/acre in 200 lit water (75 ml for 15 lit spray pump)	75 days after Planting/ ratooning
Liquid Biofungicide	Drenching of liquid biofungicide @ 1 lit/acre in 200 lit water. (75 ml for 15 lit spray pump)	70 days after Planting/ ratooning
Plant health	Foliar application of Plant health @ 1 lit/acre in 200 lit water. (75 ml for 15 lit spray pump)	75 days after Planting/ ratooning
Soil Health (SH)	Drenching of SH @ 1 lit/acre in 200 lit water (75 ml for 15 lit spray pump)	90 days after Planting/ ratooning
Liquid Biopesticide (BVM)	Drenching of BVM @ 2 lit/acre in 200 lit water (150 ml for 15 lit spray pump)	120 Days after Planting/ ratooning
Liquid Biopesticide (EPN) if infestation of	Drenching of EPN @ 1 lit/acre in 200 lit water (75 ml for 15 lit spray pump)	120 Days after Planting/ ratooning

Mechanical, biological and chemical management of pests in sugarcane

- The effective management of the sugarcane insect pests is possible by management of adult stage of insect pest at right stage, proper tillage operations and use of biological & chemical pesticides with precise dose at right time.
- To manage the infestation of insect pests in sugarcane, the right strategy should be adopted by the farmers by collective manner.
- Physical means like crosswise ploughing after harvest of previous crop, use of commercial seed for planting, use of organic manures along with bio-control agents, use of different kind of insect traps, integrated use of fertilizers, effective water usage supported by proper drainage, crop rotation, proper small and final earthing up, detrashing of sugarcane at fifth, seventh and ninth months age of crop should be adopted for the management of insect pests in sugarcane.
- Use recommended bioagents viz., *Metarrhizium anisopliae*, *Epiricania melanoleuca*, *Beauveria bassiana*, EPN, *Trichogramma chilonis*, *Trichogramma japonicum*, *Cryosoperla carnae*, *Verticillium lacany* etc. at right time with right dose for the management of different kinds of insect pests in sugarcane.
- Sett treatment before planting of sugarcane by dipping of setts in 100 lit. of water solution containing carbendazim – 50 wp, 100 gm and Imidachloprid 70% WG @36 gm may prevent the spread of pests through setts.
- Release of egg parasitoid *Trichogramma chilonis* in field @ 3-5 Lac parasitized eggs /ha in suitable



installments for preventive management of early shoot borer of sugarcane.

- Soil application of Fipronil 0.3 GR @ 25 kg/ha or Chlorantraniliprole 0.4 GR @ 22.5 kg/ha at planting and 60 days after planting is recommended for the management of early shoot borer.
- Collection and destruction of adult beetle by using light trap, drenching of EPN (*Hererorhabditis* sp.) 2.5 lit/ha and drenching of Fipronil 40% + Imidachloprid 40% WG @ 500gm in 1000 liter water will manage the white grub in sugarcane, effectively.
- *Beauveria bassiana*, *Metarrhizium anisopliae*, *Verticillium lecanii* and *Aschersonia placenta*, *Encarsia formosa* Gahan, and predators *Serangisetum paracetosumare* are the natural enemies recorded to reduce the white fly incidence in field.
- Clipping of 2-3 leaves containing black cocoons followed by two sprayings (with 15 days interval) of Imidachloprid 17.8 % SL @ 300 ml/ha (0.3 ml/lit) plus 2 % Urea will reduce the infestation of white fly.
- Sugar mills should implement three tier seed nursery programme for the supply of good quality pest/disease free planting material for the prevention of spread of diseases and insect pests. The breeder seed in the form of tissue culture plantlets should be used for the raising of foundation seed.
- The sugar mills should adopt either moist hot air treatment plant or sett treatment device for the treatment of planting material to avoid the spread of diseases through setts.
- The disease control measures *viz.*, integrated fertilizer use on the basis of soil test, adoption of long furrow and pair row method of planting, use of fungicides at the initiation of the disease, use of inputs containing silicon & chitosan for improving the resistance against the attack of diseases, timely application of agricultural inputs *etc.* should be undertaken so as to keep the sugarcane crop healthy to tolerate the incidence of diseases.
- Apply liquid Biopesticides @ 5 lit/ha along with 500kg of FYM/compost in soil or 2 lit liquid biopesticides along with 200 lit of water by drenching in furrow at the time of planting for the management of soil borne pathogens.

- Bio-pesticides offer better alternative to synthetic pesticides due to their low toxicity, biodegradability and low persistence in the environment.

EXTENSION AND ADVISORY SERVICES

Consultation for cane development

- Olam Agri. Commodities India Pvt. Ltd., Kolhapur
- Harvesting programme
- Vitthalrao Shinde SSK
- Sidheshwar SSK
- Sahyadri SSK
- Vishwasrao Naik SSK
- Sonhira SSK

PRODUCTION AND SUPPLY

Micropropogated plantlets

Tissue culture section produced and supplied of micropropogated plantlets are given in table 9 and 10 (please see page no. 44 and 45).

Multimicronutrient and multimacronutrient liquid fertilizer production

Soil Science section produced and supplied the State Govt. notified grade of multi-micronutrient (grade-2), multi-macronutrient (NPK8:8:8), multi-macronutrient water soluble (NPK 15:15:15), Microsol (grade-1 solid soluble micronutrient mixture) and VSI-Humic to sugar mills and individual farmers in Maharashtra. The details supply of the products are given in following table 17.

Table 17 : Supply of agro-products

Particulars	Quantity
Multi-micronutrient liquid fertilizer	64683 lit
Multi-macronutrient liquid fertilizer (NPK 8:8:8)	11365 lit
Multi-macronutrient fertilizer (NPK 15:15:15)	30075 kg
VSI-Microsol	46585 kg
VSI-Humic	18058 lit
Total	1,70,766

Liquid bio-fertilizers

The section has produced 1,53,191 liters of different types of liquid bio-fertilizers, biopesticides, biofungicide & 12,520 lit Vermiwash and supplied 1,44,608 liters of liquid biofertilizers, biopesticides & biofungicide to various farmers from Maharashtra state and other states and 12518 lit. Vermiwash to LBF production unit and 2251 lit, LBF/LBP supplied to various departments of the Institute. The details are given in table 18.

Table 18: Supply of liquid biofertilizers/biocontrol agents

Particulars	Supply (lit)
Acetobacter	1831
Azo-phospho	2664
Decomposing Culture	17924
Rhizo-phospho	321
Sulphur Oxidizing microorganisms	1231
Soil health	32617
Plant health	24716
Silicate Solubilizing bacteria	1146
Potash mobilizing bacteria	4583
Iron & Zinc solubilizing microorganisms	873
Azotobacter	95
Phosphate Solubilizing Bacteria	1256
Biopesticide (BVM)	28926
Biopesticide (EPN)	14449
Biofungicide	11661
Pacelomyces	188
Vermiwash Sale	126
PGPR	1
Departmental	2251
Total	1,46,859

Vermicompost

The section has produced 249.560 metric tons of vermicompost and supplied 260.15 tons, out of which 220.05 tons was supplied to various departments in the Institute for experimental purpose. Remaining 40.09 tons was supplied to sugarcane growers from Maharashtra. In addition to this, 69 kg earthworms of *Eisenia foetida* was supplied to the farmers.

Microbial culture

Total Twenty-five slants were supplied to the sugar mills, Vighnagar SSK (1 no.), Vishwasrao Naik SSK (15 no.s), Sudhakarparant Paricharak Pandurang SSK (5 no.s), YM Krishna SSK (4 nos.), SM Bhausaheb Thorat SSK (4 no.s) which are producing different liquid biofertilizers.

Microbial analysis

Total 734 samples (In-house and outside) were analyzed. pH and Microscopy (LBF, LBP & EPN) (452). Liquid biofertilizers (145), Liquid biopesticides (56) Liquid biofungicide (24) Decomposing culture (30) Chemicals (27) analyzed for microbial counts.

Outside samples (34) sectional soil (87) Vermicompost sample (249), Interdepartmental soil (69) plant (59) analyzed for microbial counts.

Tricho cards

Produced 2825cc *Corcyra* eggs and 1565 *Trichogramma chilonis* (TC) & 573 *Trichogramma pretiosum* (TP) cards and supplied 1067 TC cards and 323 TP cards for management of borer insect pest.

Nucleus culture

Total 3 *Trichogramma chilonis* card were supplied to Bio-control lab viz., YM Krishana SSK, Satara (2), Agriculture college, Pune (1). Total 7 *Trichogramma pretiosum* card were supplied to Bio-control lab viz., NARP, Aurangabad (2), YM Krishana SSK, Satara (4), Agriculture College, Pune (1). Total 166 cc *Corcyra* eggs were supplied to Bio-control lab viz., Nasakh Agro Dhule (100), NARP, Aurangabad (35), Agri-culture College, Pune (25), Agriculture College, Kolhapur (6).

Agriculture tools

During the year under report, 166 VSI developed harvesting knives were supplied to the farmers.

Analytical services

Soil/Fertilizer/Chemical testing

It has been recommended that the application of fertilizers should be done on the basis of soil analysis. A total of 205 soil samples and 43 compost samples received from sugar mills and individual farmers were analyzed for various parameters like pH, EC, organic carbon, calcium carbonate, available nitrogen, phosphorous, potassium and micronutrient etc. The detailed analysis was carried out and fertilizer dose were recommended on the basis of analytical data. Total 1558 soil samples and 1618 sugarcane leaf samples of research trials were analyzed for different parameters and nutrient contents as an important part of scientific research on nutrient management. In addition, total 369 process chemical and fertilizer samples received from sugar mill and private organizations were analyzed.

Drip and sprinkler material testing laboratory

Accreditation of drip and sprinkler material testing laboratory is renewed by NABL accreditation till February 2026 after onsite assessment by the team of experts. During the year 250 samples were tested in the laboratory.

SUGAR TECHNOLOGY



SUGAR TECHNOLOGY

The department works for performance improvement of the sugar mills to produce good quality sugar with minimum sugar losses and continual upgradation of technical knowledge in process through applied research, extension & advisory services, academic activity, analytical services, process validation for diversion of feedstocks.

Under applied research, research projects are taken up in collaboration with other institutions/sugar mills based on the difficulties faced by sugar mills during the sugar manufacturing process. These projects are aimed for improvement in quality of final product & conservation of energy and lowering cost of production.

The department guides the member sugar mills for technical performance improvement. The major areas are producing quality sugar, reduction of sugar losses, improvement in capacity utilization, and reduction in process steam & water consumption with addition of modern equipment, implementing the latest technologies and rendering required proficiency. Department also provides consultancy services for new evaporator configuration for complete defecated syrup diversion to distillery as per new ethanol policy and modification of existing evaporator configuration with the diversion of feedstocks.

The department is also providing consultancy services for modernization & expansion, preparation of detailed project report of the boiling house, effluent treatment plant, condensate polishing unit, water management and ETP adequacy assessment for the member and non-member sugar mills.

The department participated in the inspection of Gross Polluting Industries (GPI). This work is given by the Central Pollution Control Board (CPCB) in basin of river Ganga and Yamuna. Under the Central Government EBP programme, department continued process validation of the sugar mills diverted the feedstocks for ethanol production as per the DFPD. The Sugar Commissioner of Maharashtra state has allotted the responsibility of FRP recovery assessment and certification of sugar mills diverted different stocks in the state to VSI.

The department conducted regular classroom lectures and practical sessions for courses in Sugar Technology, Sugar Manufacturing Certificate, Sugar Boiling, Sugar Engineering Diploma and Sugar Engineering Certificate. The sugar laboratory extends analytical services to sugar mills.

RESEARCH AND DEVELOPMENT

Clarification of intermediate molasses for better keeping quality of sugar

The plant scale trials for R & D project of clarification of intermediate molasses for better keeping quality of sugar conducted at Krantiagrani Dr. G.D. Bapu Lad SSK were continued during the season 2023-24. The sugar mill fabricated and installed clarifier under the guidance of the department. Erection of the clarifier was completed by the extreme end of crushing season 2021-22, but project was delayed due to expansion of sugar mill and B Heavy clarifier accessories were dismantled for plant expansion works. Before starting of crushing season 2023-24, sugar mill made necessary arrangements to conduct the plant scale trial. Sugar mill and VSI jointly conducted the plant scale trial and the observations were as mentioned below.

- C m/c boiling is improved and got better exhaustion.
- Purity drop from C m/c to final molasses increased by 3 units.
- Reduction in viscosity of B Heavy molasses around 40%
- Operation period of C Continuous pan between water boiling increased from 30 days to 50 days.
- Continuous centrifugal machines capacity increased with improvement in massecuite quality.

However, during the ensuing season 2024-25, further trials of B Heavy molasses clarification system will be conducted by doing the required modifications to operate the clarifier at the rated capacity of the plant.

Treatment of spray pond water by carbon particle from ESP/ Wet scrubber to minimize the raw water addition in spray pond

The project was executed in four sugar mills and results achieved include rise in pH by 0.5 units,



reduction in TSS by 88%, COD and BOD reduction by 40%, reduction in lime consumption at spray pond and effluent load on ETP by 50%. However, TDS of the treated water increased by 16%. Further, lab scale trials were carried out to reduce the TDS of the treated water by the following methods.

- a. Using Synthetic Polymer
- b. By physical heating
- c. Passing through R.O.

The first two methods were tried at Shree Datta SSK, Shirol. They are technically feasible but economically not viable. After discussion with various suppliers it was concluded that method 'C' is not economically viable.

Re-use of treated effluent from small scale industries by evaporation process using double effect evaporator

The project was taken up by the department last year to minimize fresh water consumption. It is proposed to use the condensate water obtained from effluent treated by double effect condensing evaporator. This project is helpful to reduce the ground water consumption by industry. At present the small scale industries are consuming large amount of fresh water and generating approximately same quantity of effluent which is affecting ground water quality. The concept of the project is developed due to following points.

- Small scale industry has batch type ETP with chemical treatment.
- The effluent after primary treatment is being discharged in to common effluent treatment Plant (CETP) as it will not meet statutory requirements of PCB.
- Large quantity of fresh water is being used in process by the industries resulting in higher quantity of effluent water generation.

Work progress

Four samples were collected from various small scale industries out of which three samples were from electroplating industry and one sample was from dye industry.

Lab scale trials were conducted at VSI using the existing double distillation plant in the department. Based on the results, it was observed that there is

reduction in TDS by 97%, TSS by 95%, Sulphates and chlorides by 99% from untreated water to treated water. Results found satisfactory as per the lab scale trials.

Sulphured juice heating by flue gas through single pass horizontal heater

The objective of this project is to recover waste heat from flue gas to reduce steam % cane with modified evaporator configuration. The procedure considered is explained as under

- Utilization of flue gas for sulphured juice heating.
- Design of horizontal single pass juice heater in which scrubbed flue gas will be used as heating media in single pass counter current tubular heater. Considering that no deposition of carbon particles on outer surface of tubes.

Work progress

Correspondence was initiated with member and non-member sugar mills for funding and to carry out this project.

B & C sugar melting by using clear juice in double sulphitation process during syrup and BH diversion

Department has taken this project after studying BH/Syrup process validation at different sugar mills those who have diverted BH molasses/Syrup, partial sugar cane juice for production of fuel ethanol for blending with fossil fuel as per policy of Govt. of India. The importance of this project is to replace the use of steam, process condensate or syrup with clear juice for B & C sugar melting, so as to reduce foaming at melter while, using sulphited syrup and to balance the vapour load at evaporator condenser during BH molasses diversion for bio-fuel (ethanol) production.

This project was conducted at 3 sugar mills namely Udagiri Sugar & Power, Kumbhi Kasari SSK and Sahakar Maharshi Bhausahab Thorat SSK during the crushing season 2022-23 by using clear juice for low grade sugar melting. Based on the observation and analytical data, it was observed that the reduction in steam consumption by 0.5% on cane, sugar colour reduced by 10 IU.

Online colour measurement of clear juice using AI techniques in collaboration with COEP

The final sugar colour is directly proportional to the colour of clear juice. There must be consistency of juice

clarification in order to produce the sugar with uniform colour and good quality. The department initiated this project for production of quality sugar with good colour. To achieve this continuous monitoring and measurement of clear juice is essential. Measurement of clear juice colour in sugar laboratory takes about 30-45 minutes which includes collection of sample, taking sample to laboratory, sample cooling, filtration, pH correction, Absorbance measurement and calculation. By this mean time, huge quantity of clear juice (may be inferior quality) passes to the process for further sugar production which cannot be rectified and adversely affect the final sugar colour.

If online colour of clear juice is available and it exceeds the limit, corrective action will be taken immediately at clarification station and uniform colour of clear juice can be maintained. Hence, this project is planned for improving the sugar colour to fetch the additional premium in the market & financial benefit to the sugar mill.

Project status

Purchase of required glass container, high resolution camera and other electronic equipment, clear juice auto sampler box was completed. Assembling of the camera and sampling glass container with other equipment done by M/s. Softhard Automation, Pune along with its automation. After adjustment of the lighting arrangement in the auto sampler system at VSI, this system was installed in three sugar mills for data collection during the season 2023-24. During the season 2023-24, we have collected data of 1288 samples of colour range 6000IU to 21000IU from three sugar mills namely Malegaon SSK, Someshwar SSK and Shreenath Mhaskoba Sakhar Karkhana. A database of these lab results having different colour range of clear juice was created with COEP. This database is submitted to COEP for further testing and validation of data, development of soft sensor. Soft sensor preparation is going on at COEP which expected to complete by June 2024.

Filtrate juice clarification by sedimentation process to avoid re-circulation of non-sugar & coloring matter

The main objective of the project is to remove the colouring matter in the filtrate juice and reduce the load on the main juice clarifier. The main purpose of this

project is;

- Clarification by sedimentation process.
- Removing suspended matter from filtrate juice.
- Removing colouring matter.
- Improve the purity of clear filtrate juice.
- Sediment sent to muddy juice tank for desugarization.
- Clear filtrate sent to evaporator station along with clear juice.

Project status

Lab scale trials of this project were conducted at Shri Datta SSK by increasing filtrate juice to various temperatures i.e., 85, 90, 95 and 100°C along with addition of 2 PPM flocculant. 6 sets of samples conducted at various temperatures @ 85, 90, 95 & 100°C. All the samples analyzed for various parameters like pH, Brix%, Pol%, Purity, Colour IU, P₂O₅ content, CaO, transmittance and turbidity. Settling time and mud volumes of the samples were also recorded.

A result indicates that clear filtrate juice quality was good at 95°C. The following are the observations at 95°C.

- Raise in purity by 1.8 units
- Reduction in colour by 14%
- Reduction in turbidity by 30%

Plant scale trials of this project are to be started.

Sugar Laboratory

Sugar laboratory was assessed by NABL team in the month of November 2023 and NABL accreditation certification validity was extended upto February 9, 2026 with existing scope of sugar analysis.

Details of analysis done

There are total twelve test parameters related to sugar quality under the scope of this laboratory. Total 725 samples of sugar and molasses were received in sugar laboratory for analysis of different parameters. Out of this, 448 sugar samples for ICUMSA Colour by different methods, 128 samples for conductivity ash%, 209 samples for moisture%, 186 samples for SO₂ content, 192 samples for Pol%, 63 samples for reducing sugar and 224 samples for total reducing sugar analysis of Syrup, B Heavy and C Heavy molasses were carried out.

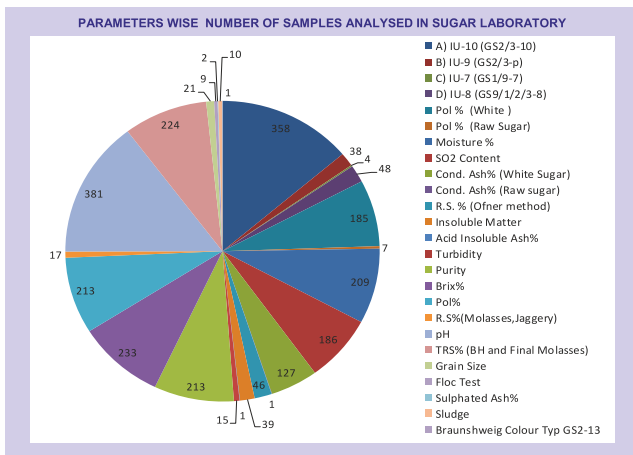

EXTENSION AND ADVISORY SERVICES

Sugar technologists undertook 453 visits to sugar mills for extending consultancy services as follows.

- Increase in capacity utilization.
- Reduction of sugar losses in manufacturing process.
- Improvement in sugar quality.
- Improvement in overall technical efficiency.
- Conservation of steam, power and water.
- Zero fresh water requirement and minimizing effluent generation in sugar mills.
- Verification of ETP adequacy and water balance of sugar mills.
- Optimization of process chemicals dosage.
- Logic for automation at different stations in boiling house.
- Selection of Technical Personnel in sugar mills.
- Detailed Project Reports (DPR) regarding modifications, additions, alterations, modernization and expansion of boiling house.
- Validation of different feedstocks diversion for ethanol production.

Achievements

Dr. Patangrao Kadam Sonhira SSK

During the season 2022-23, the plant was operating at the crushing rate of 6500 TCD. The management proposed to increase the crushing capacity and modernize the plant in view of more cane potential in the area of operation. The sugar mill proposed to crush the whole cane with in minimum/ short time period of high recovery along with reducing the steam consumption and diversion of syrup and B Heavy molasses to the distillery for ethanol production. The aim of this project is to enhance crush rate with the

existing available steam and saving sufficient bagasse required for the off season distillery operations. The department modified evaporator configuration to use the third vapor for pan boiling with the addition of four numbers of 6000 m² FFE and other required steam saving systems. Steam consumption was reduced from 40 to 34% on cane achieving bagasse savings of 5.82% on cane with the diversion of syrup and B Heavy molasses to distillery.

Vilas SSK Unit-1

During the season 2022-23, the sugar mill was operating at an average crushing capacity of 4100 TCD with steam consumption around 42 to 43% on cane. It also diverted Syrup and B Heavy molasses to distillery for ethanol production. Sugar mill approached the department for modernization of plant to reduce the steam consumption, improve the sugar colour along with improving the boiling house efficiency. Accordingly, the evaporator configuration was changed by adding new evaporator bodies and profuse vapour bleeding. Sugar mill achieved average crushing rate of 4600 TCD and steam consumption reduced to 37% on cane with three massecuite boiling.

KAT Samarth SSK Unit-I

The sugar mill management proposed to increase the crushing capacity from 4000 to 7500 TCD along with diverting defecated evaporator syrup of nearly 800 MT per day to the distillery of 230 KLPD (with syrup) for ethanol production. Technologists from the department designed the juice defecation plant and evaporator configuration. Evaporator station was provided with four Robert type evaporator bodies of 1500 m² heating surface with vapor line juice heater to achieve raw juice temperature in single stage and to produce the defecated syrup required for the distillery. Defecated syrup plant was successfully commissioned during the season 2023-24 and achieved the average steam consumption of 26-27% on cane.

Sahyadri SSK, Karad

Initially sugar mill was not able to achieve average crushing rate of 7000 TCD. Technologists from the department visited and studied the evaporator station, vapor bleeding and other areas. It was suggested to maintain exhaust pressure of 1 kg/cm² uniformly at calandria of first body and also to maintain the optimum juice level in SK & VC to achieve the ideal

evaporation rate. With the implementation of these steps, 1st and 2nd vapor temperatures improved accordingly, which ultimately helped to increase the pan boiling. With this sugar mill achieved the crushing rate of + 8000 TCD on average basis during that period. Sugar colour was observed in the range of 130 IU. Feed material used for the A massecuite were checked and A Light molasses purity was found on lower side due to improper syrup separator operation at A massecuite centrifugal. Accordingly, timer was adjusted and improved the A Light molasses purity. It was also suggested to improve the B seed purity at B centrifugal machines. By implementing all these measures, sugar colour got improved to less than 100 IU.

Shree Sayan Vibhag Khand Udyog Mandli, Gujarat

Initially the sugar colour in this mill was 130 IU to 140 IU. After visiting plant, it was suggested to improve the quality of melt and AL molasses. Dry seed size and quality was enhanced by installing vibro screen at grader before sending to pan station. At pan station movement water quantity was monitored by installing flow meter. After implementation of the entire above points sugar colour was achieved up to 65 to 70 IU. Final molasses purity reduction was done by improving

C pan boiling after suggesting to follow 2C graining method instead of 3C graining, good grain quantity and hardening, efficient conditioning of C m/c were suggested. After implementation of all the above points final molasses purity got reduced from 36 to 32.

Karmveer Shankarrao Kale SSK, Kolpewadi

The management proposed to increase the crushing capacity from 4000 TCD to 6600 TCD for the season 2023-24 and to reduce the steam consumption to 32%. New equipment was suggested in DPR prepared by the department. Erection and commissioning of equipment was completed during the season 2023-24 and sugar mill achieved the steam consumption of 32% on cane and bagasse saving around 8% on cane. By installing hot raw juice screen before juice sulphitor, Syrup clarification and adopting A1 massecuite boiling, sugar colour was reduced from 100 IU to 55 IU as compared to last season. The Results are given in table 1.

PREPARATION OF DETAILED PROJECT REPORTS

Prepared 'Detailed Project Report' for boiling house machinery of the sugar mills for modernization, expansion and appraisal are given in table 2.

Table 1: Results achieved by sugar mill

Sr. No.	Parameters	Season - 2022-23	Season 2023-24
1	Crushing rate (TCD)	Below 4000	Average 6000
2	Steam % cane	44	33
3	Bagasse Saved (%)	2	8
4	Sugar Colour (IU)	Above 100	55-65

Table 2: Detailed Project Reports for sugar mills

Name of Mill	Type of Detailed Project Report (Boiling house)
Shree Sayan Vibhag Sahakari Khand Udyog Mandli, Gujarat	Expansion of plant from 6000 TCD to 7000 TCD with below 40 % steam consumption
Ukai Pradesh Sahakari Khand Udyog, Vyara, Gujarat	Modernization of plant for 2500 TCD with below 40 % steam consumption
Vilas SSK unit no.2	Expansion from 2500 TCD to 4950 TCD
Sharad SSK	Expansion from 2500 TCD to 7500 TCD
Vighnagar SSK	Expansion from 5000 TCD to 7500 TCD
KAT Samarth SSK	Boiling house equipment addition of the defecated syrup plant expanded from 3500 to 7500 TCD.
Dr. PK Sonhira SSK	Expansion from 5000 TCD to 9500 TCD with 2000 TCD Syrup diversion.
Shankar SSK	Expansion from 2500 TCD to 5000 TCD
Ambalika Sugar	Expansion from 12500 TCD to 17000 TCD
Mohanrao Shinde SSK	Modernization for 4000 TCD for steam economy



Preparation of tender specifications

Tender specifications for boiling house machinery of following sugar mills are given in table 3.

Extension and Advisory Services to member and non-member sugar mills: The consultancy services provided to member and non-member sugar mills in the state & outside state are given in table no. 4 and 5.

Table 3: Detailed Tender Specifications for sugar mills

Name of Mill	Boiling house specifications details
Vilas SSK Unit II	Expansion from 2500 TCD to 4950 TCD
Vighnagar SSK	Expansion from 5000 TCD to 7500 TCD
KAT Samarth SSK	Boiling house equipment addition of the defecated syrup plant expanded from 5000 to 7500 TCD
Ambalika Sugar	Expansion from 12500 TCD to 17000 TCD
Dr. PK Sonhira SSK	Expansion from 5000 TCD to 9500 TCD with 2000 TCD Syrup diversion
Mohanrao Shinde SSK	Modernization for 4000 TCD for steam economy
Vilas SSK Unit I	Modernization of Boiling house machinery for 3500 TCD
Chhatrapati Rajaram SSK	Modernization of Boiling house machinery for 3500 TCD

Table 4: List of member sugar mills to which the technologists paid visits to extend consultancy Services

Name of Mill	Brief description of consultancy
SMSN Nagawade SSK	Meeting with NCDC representative
Vishwasrao Naik SSK	Suggestions for plant expansion
SMS Mohite Patil SSK	Equipment Verification
SMS Kolhe SSK	Regarding plant expansion
Daund Sugar	Steam Saving suggestion in refinery
K. S. Kale SSK	Project review meeting and interview of different manufacturing posts. Commissioning of new project, performance guarantee test
Daund Sugar Pvt. Ltd.	Performance observation of new refinery
Venkataswara Power Projects (KA)	Performance observation of new project
Datta SSK	Performance observation of new project Evaporator configuration during diversion of BH molasses
Sahyadri SSK	Low crushing problem
Shree Mahuva Pradesh Khand Udyog Mandli, Mahuva (GJ)	DFPD guidelines for BH diversion and plant expansion
SMS Kolhe SSK	Performance observations of new installed equipment.
TK Warna SSK	Performance assessment of the plant
Dr. PK Sonhira SSK	Higher Bagasse Pol problem
Kisanveer SSK	Performance assessment of the plant and expansion
Bhaurao Chavan SSK Unit I	Steam economy for expanded capacity
Bhaurao Chavan SSK Unit II	Steam economy for expanded capacity
Vitthalrao Shinde SSK- Unit I	Discussion on new Backend refinery 7000 TCD regarding

Table 4: List of member sugar mills to which the technologists paid visits to extend consultancy Services (Contd.)

Name of Mill	Brief description of consultancy
L Sunderaoji Solanke SSK	Improvement in boiling house performance
Krantiagrani Dr. GD Bapu Lad SSK	Discussion on A2 m/c boiling
Dr. Babasaheb Ambedkar SSK	Performance assessment of the plant
Rena SSK	Expansion project consultancy
Vilas SSK Unit I	Modernization project consultancy, improvement in boiling house performance
VVD Manjara SSK	Call visit for Process problems
Shri Sant Shiromani Maruti Maharaj SSK	Assessment of boiling house machinery for 2500 TCD
Halshidhanth SSK (KA)	Assessment of boiling house machinery for 7500 TCD
Sharayu Agro Ind.	Juice & syrup clarification stations performance assessment
Shree Vighnahr SSK	Higher total losses- Bagasse pol, filter cake and BH molasses
Shree Shankar SSK	Higher total losses- Bagasse pol, filter cake and BH molasses
Shri Sant Tukaram SSK	Mud problem
KAT Samarth Unit I	Study of boiling house equipment for 6000 TCD
Rana Sugar	Training on Sugar beet analysis procedures
Mahankali SSK	Study of boiling house equipment for 3000 TCD

Table 5: Consultancy Services to Non-member Sugar Mills

Name of the factory	Brief description of consultancy services
The Nandi SSK (KA)	Plant expansion review meeting, Plant expansion review meeting and interview for GM & DGM posts
Shree Sayan Vibhag Khand Udyog Mandli, Sayan (GJ)	Overall Performance Assessment
Sri Sai Priya Sugar	Refined sugar production & Technical performance Audit
UP State Corporation, Munderwa, Gorakhpur (UP)	Consultancy for Performance assessment & improvement
UP State Corporation, Pipraich, Basti (UP)	Consultancy for Performance assessment & improvement
Shree Kranti Sugar & Power	Consultancy for Performance assessment & improvement
Anamika Sugars	Consultancy for DPR preparation of new backend refinery
Dhampur Bio-Organics Asmoli Unit	Consultancy for reduction in final molasses purity
Yeshwant Sugar & Power	Assessment of boiling house for 2500 TCD.
Manjra Sugar Industries	Assessment of boiling house for 5000 TCD.
Shri Kedarnath Sugar & Agro product	Technical Performance Audit
Badami Sugar (KA)	Technical Performance Audit
MRN Sugar (KA)	Technical Performance Audit
MRN Sugars and Power (KA)	Technical Performance Audit
Sahakari Khand Udyog Mandli, Gandevi, (GJ)	Technical Performance Audit



Suggestions for improvement in overall technical performance

The technical team of department visited 31 sugar mills to improve their overall technical performance like sugar colour, steam consumption & total sugar losses etc.

Steam and energy conservation

With BH diversion to the distillery, the operation days of distillery units increased during the off season. With this sugar mills are interested to reduce process steam consumption to save the bagasse for the off season. 16 sugar mills were visited by the department for steam and energy conservation.

Off-season maintenance works

Off-Season maintenance of the equipment plays major role in smooth operation of sugar mill during the season. Department team visited 12 sugar mills to provide the guidelines on the off-season maintenance works along with required modifications of the equipment to avoid the equipment break down and to improve the process performance.

Low crush rate problem

Technologists of the department visited three sugar mills namely, VVD Manjara SSK, Sahyadri SSK and Shree Datta Shetkari SSK to study the process problems so as to improve crushing rate of the sugar mill.

Low recovery problem

Sugar recovery is one of the major indicator to evaluate the process performance. Total six sugar mills were visited by the department team to evaluate the sugar input i.e. cane quality, sugar losses through various by products and unknown losses.

Process validation of different feedstocks diversion for ethanol production in sugar mills

Under EBP program office Memorandum F.No.4/1/2018-(BP&E) dated 02/12/2021 guidelines received from Department of Food & Public Distribution, Government of India allotted the responsibility for process validation of sugar mills diverted different feedstocks to distillery for ethanol production. Accordingly total 128 sugar mills (81 member sugar mills & 42 nonmember sugar mills) within Maharashtra and 5 sugar mills from other states

were visited by officers of the department to validate the process of diversion of cane juice, thick juice, syrup & BH molasses for ethanol production during the season 2023-24.

Assessment certificate for FRP recovery of sugar mills

This year also Sugar Commissioner of Maharashtra state has allotted the responsibility of FRP recovery assessment and certification of sugar mills diverted different stocks in the state to VSI. The department has done FRP recovery certification of 123 sugar mills in Maharashtra state diverted various feedstocks viz. mixed juice, thick juice, syrup, and BH-molasses for ethanol production for the season 2023-24. This certification is done as per advice of Director (Finance), Sugar Commissionerate Maharashtra.

ETP & water management

Effluent treatment plays an important role in the environment protection. ETP station enable in achieving norms laid down by Pollution Control Board.

- Central Pollution Control Board (CPCB) has given responsibility of inspecting Gross Polluting Industries (GPI) in Ganga and Yamuna river basin. Accordingly, total 70 industries were inspected by the department team out of which 14 textile and 56 other industries.
- Technical experts visited 12 sugar mills out of which ten sugar mills to carryout ETP upgradation & waste water management and two sugar mills for verification of water balance & preparation of ETP adequacy report.
- Prepared technical specifications of sugar ETP and CPU for KS Kale SSK

Selection of suitable candidates for technical posts in sugar institute & sugar factories

As per the request by the sugar mills, technologists joined with interview board for the selection of suitable candidates for various technical posts like Managing Director, Works Manager, Chief Chemist, Manufacturing chemist, Pan man & Lab Incharge etc. at four sugar mills.

Short training programmes organized by VSI

Various short term training programmes were conducted by the department in different streams like

Special analysis in sugar laboratory, juice clarification & evaporation, pan boiling & centrifugal. Technical team also conducted training on FRP recovery calculation during feedstock diversion as per DFPD guidelines for the technical people from sugar mills of Kolhapur, Pune, Ahmednagar, Aurangabad & Nanded regions which was arranged by Regional Joint Director, Sugar Commissionerate Office and two sugar mills in Gujrat.

Educational activity (regular courses)

Lectures and practical's for the regular courses like Sugar Technology, Sugar Manufacturing Certificate, Sugar Engineering Diploma, Sugar Engineering

Certificate and Sugar Boiling Certificate courses etc. were conducted by off line mode at VSI.

Campus interviews for the students

This year campus interviews were conducted by M/s. EID Parry India, NSL Sugar Karnataka, Spray Engineering Devices, Sharayu Agro, Jaihind Sugar and Durga Sugar, Madhya Pradesh. 12 students from final semester of sugar technology course were selected. Also, as per the requirement from various sugar mills, department deputed students of ST-III & ST-I courses as trainee chemists.



The Technical Committee meeting for Technical departments chaired by Hon. Shri. Jayant Patil



Visit of delegation from Stonex Group, Brazil



Visit of delegation from Philippines

SUGAR ENGINEERING



SUGAR ENGINEERING

The Sugar Engineering Department is dedicated for providing comprehensive services to the sugar industry. The department caters to all aspects of conventional as well as emerging modern technologies for juice extraction, juice processing, automation, co-generation, steam, power, and water conservation. The department also offers consulting services and need-based applied research and development. This allows sugar industries to gain insight into the latest technologies and trends in the industry and to identify areas where they can improve their production processes.

The department offers consultancy services for the preparation of detailed project reports (DPRs), tender technical specifications, scrutiny of designs and drawings, inspection of plant and machinery, guidance during erection and commissioning, technical audits, and performance evaluation of sugar, co-generation, and distillery captive power projects.

During this financial year, the department prepared detailed project reports for five bagasse-based co-generation plants with a total installed capacity of 87MW. currently, two projects of 32MW are under execution, and one cogeneration project with a capacity of 12.50MW has been executed.

The department is involved in handling zero liquid discharge projects, including spent wash-fired incineration boilers, with matching captive power projects for distilleries. To date, 28 zero liquid discharge projects have been executed, and 4 projects are in the pipeline.

The department has been engaged in ten applied R&D projects and has published eight research papers in national and international journals during the reporting period.

The department is also involved in the academic activities. This includes tailor-made training programmes for the technical staff of sugar mills in the state, from other states and countries. The department also provides classroom lectures to students enrolled in the academic courses Diploma and Certificate in Sugar Engineering, Sugar Processing, Alcohol Technology & Biofuels, etc. Department engineers teach the latest technologies and equipments, as well as techniques to

optimize the performance of existing plants and the machineries.

RESEARCH & DEVELOPMENT

The An extensive research and development project is being conducted to cater the specific needs of sugar mills and co-generation systems. Research and development (R&D) plays a crucial role in the development of industry. The findings of these result-oriented projects have been presented in the form of research papers at various national and international conventions. To promote the viability and sustainability of the sugar industry, VSI has partnered with COEP to conduct joint R&D projects. The memorandum of understanding (MOU) between these two institutions encourages academic collaboration, applied research, and industry relationships.

Life assessment of the roller chain for the sugar industry

A joint study with COEP was conducted to analyse the composition of raw materials in relation to breaking load. A inter-rake carrier block type chain with a breaking strength of 60000 kg was selected for study which consists of;

- Static analysis of all parts of the inter-rake carrier block type chain (like the roller pin, roller bush, and forged link)
- Finite element analysis (FEA) of all parts of the roller chain.
- Suggesting an appropriate material for the chain to meet the design requirement based on the results.
- Determining the wear rate and coefficient of friction between the roller pin and bush materials under different operating conditions.

This study was carried out in two phases. In the first phase, static analysis was carried out on all parts of the inter-rake carrier roller chain (like the roller pin, roller bush, and link) using the theoretical and FEA methods. The initial materials of pins (stainless steel) and block-type links (forged steel) failed to meet the design requirements as per theoretical and FEA analysis. Therefore, an analysis of mechanical properties and material availability was conducted to determine alternative materials. After analysing the findings,



an alternative material was recommended to replace the failed material in order to meet the design requirements. It was recommended to use AISI 4140 for stainless steel pins and AISI 4340 for forged steel links in future designs. These recommended materials have been proven to meet the design requirements for breaking loads.

In the second phase, the focus of this analysis was to evaluate the wear resistance, coefficient of friction, and frictional behaviour of the roller pin and roller in an inter-rake carrier chain used in the sugarcane industry. To do this, a pin-on-disc experiment was conducted using SS410 as the roller pin and OHNS (oil-hardening non-shrinking material) steel as the roller bush. The Taguchi L9 method was used to vary the process parameters such as rpm, applied load, and test duration. This allowed for the investigation of their effects on the wear rate and coefficient of friction. An LVDT sensor was used to measure the friction force during each experimental run. The results of the study showed that the applied load had the greatest influence on the coefficient of friction and wear rate, followed by the test duration and rpm. These findings can be used to improve the performance and durability of the inter-rake carrier chain, leading to increased efficiency, life and productivity in the sugarcane industry. The Taguchi L9 method was chosen for the experiment design because it allowed for the simultaneous evaluation of multiple process parameters with a minimal number of experiments.

The coefficient of friction for SS410 can vary based on the conditions and the material it is in contact with. Typically, it falls within the range of 0.2 to 0.6. In our experiment, we obtained a coefficient of friction that ranged between 0.2 and 0.28.

Investigation of the combustion, performance, and emission characteristics of an alcohol fuelled (ethanol) Common Rail Direct Injection (CRDI) diesel engine

This study analysed the combustion performance and emission characteristics of a CRDI diesel engine fuelled with alcohol. The goal of the study was to determine the optimal percentage of ethanol and diesel fuel mix for the CRDI diesel engine while maintaining parameters of combustion, performance, and emissions.

The study involves,

- Development of a Reactivity Controlled Compression Ignition (RCCI) Engine.
- Optimization of injector orientation for ethanol injection Computational Fluid Dynamics (CFD) simulation.
- Evaluation of combustion, performance, and emission parameters for conventional diesel engines and ethanol-fuelled engines under RCCI operation.
- Optimization of ethanol energy share based on optimum combustion, performance, and emission parameters

The intake manifold 3D model was designed using CAD software SOLIDWORKS. This manifold is responsible for providing a mixture of liquid ethanol and air to the cylinder. To optimize the injector location on the manifold, injector orientation, and injection pressure at orientation, a CFD study was conducted. The ethanol injectors were placed within the critical distance on the intake manifold to avoid backfiring and fuel accumulation. The PC-based ECU control software was used to regulate fuel injection.

After installing the injection system, experiments were conducted using various ethanol samples from four different sugar mills. The experiments were carried out at 2000 rpm and 2400 rpm, with loads ranging from 10 Nm to 50 Nm and ethanol openings of 0%, 20%, 40%, and 60%. Based on the results obtained from this data, it can be concluded that:

The ethanol can blend up from 20% to 30% ethanol with diesel.

- For 2000 and 2400 RPM, when the load increases, NO_x emissions also increase, but increasing the openings leads to a decrease in NO_x emissions.
- For low loads, the CO emission increases as the ethanol fraction increases, while for high loads, the CO emission is almost the same for all ethanol fractions.
- HC emissions decrease as the load increases and the opening increases.
- Optimization strategies for improving engine efficiency and emission control with alcohol fuels.
- Based on the literature studies performed and the results of this research, it is possible to conclude that ethanol use in compression ignition engines operating in a dual fuel mode has great potential.

Study of the combustion control system of bagasse-fired boilers for sugar and co-generation plants

Controlling combustion is a crucial factor in improving the thermal performance of a boiler. This involves maintaining a consistent steam pressure and temperature, adjusting the fuel feed, regulating the FD and SA air fans's flow, and maintaining draft. It is also important to regulate the oxygen percentage in the dry flue gas to ensure optimal excess air for complete combustion while also preventing inefficiencies or risks associated with both excess and insufficient air. Therefore, a study was conducted with COEP to determine the optimal levels of O₂, CO₂ and CO in dry flue gases for controlling excess air and enhancing combustion efficiency.

During visits to multiple sugar factories, including Daund Sugar, Bhausaheb Thorat SSK, Sant Tukaram SSK, and Someshwar SSK. Measurement of % O₂, CO₂, and % CO in dry flue gases was carried out online, bagasse samples were collected and characterization & theoretical calculations of combustion were done.

In order to analyse and control the combustion system, it is crucial to know the accurate mass of both fuel and air. However, during the visit to various factories, it was observed that there is no facility available to measure the mass of bagasse, making it impossible to determine the actual mass of fuel and air. As a result, proceeding with this project is challenging, and the only possible way to move forward is through theoretical analysis with certain assumptions.

The project is currently on hold due to the critical obstacle of bagasse weighing as proceeding without the actual mass of bagasse is challenging.

Development of a bulging rate of tube testing system and predicting the remaining life of tubes placed in the high-temperature zone

Boiler tube failure is a major cause of forced outages, often caused by overheating, creep deformation and erosion. Excessive oxidation, corrosion, thermal creep thinning, erosion and changes in material properties can cause tubes to bulge and rupture.

At present, there is no accurate way to anticipate bulging failures in boiler tubes. This study aims to create a mathematical simulation model that can

predict the remnant life of boiler tubes made of different materials of construction (MOC) based on the bulging of tubes in high-temperature zones. The research team gathered bulged tube samples from Mula SSK, Vitthal Corporation, and Shri Sant Tukaram SSK for thorough analysis and testing.

Key progress includes

- Identification of key factors causing tube bulging.
- Simulation of the research problem.
- Development of a mathematical model.
- A conceptual design for experimental setups was created.
- The experimental test setup was fabricated, developed, and inspected before commissioning, with calibration and trial tests conducted. During calibration and pre-delivery inspections, five tubes were tested on the bulge test setup. The initial two tests did not result in fish mouth failure, leading to adjustments in operational parameters. Subsequent modifications successfully induced fish mouth failure.
- The test set-up is delivered to the COEP lab from the manufacturer's shop.
- After the installation and trial of the test set up in the COEP lab, plans for further experimental testing on tube metal samples.

A final report will be initiated upon receipt of the material, inspection, and testing results of the tested tubes. The report will assess the agreement of the mathematical equation. This study has been taken up to protect the boiler tubes in time from failures due to bulging and will help to predict boiler tube leakage and the life of the tube.

Estimation of roof-top solar systems in sugar mills and forecasting solar power generation

The sugar industry, being energy-intensive, is exploring solar power as an alternative energy source. Solar energy can be harnessed through photovoltaic (PV) or concentrated solar power (CSP) systems. Indian sugar mills, equipped with existing infrastructure and manpower, are considering PV solar plants to optimize power consumption during non-operational periods and export of surplus energy to the grid.



VSI and COEP are collaborating on a project to predict solar power generation in sugar mills. The project aims to evaluate the feasibility of installing solar panels, estimate the amount of solar energy that can be generated, analyze electricity usage, assess potential savings, and estimate the investment & payback period.

The process of predicting the amount of solar energy that can be generated at a particular location and time involves analyzing various parameters. These parameters are collected and analyzed to develop accurate forecasts that enable efficient utilization of solar power. Some of the parameters used for forecasting include relative humidity, visibility, solar radiation, cloud cover, temperature, total precipitation, capacity utilization factor (CUF), and DC and AC capacity. Historical power generation data is also used in the analysis to enhance the accuracy of the forecasts.

The power generation data was collected from the sugar industry on a daily basis, while the meteorological data was obtained from the National Centre for Medium Range Weather Forecasting (NCMRWF).

Solar power generation prediction involves using machine learning algorithms such as support vector machines (SVM), linear regression, decision trees, and neural networks. These algorithms were chosen based on their unique features and their ability to predict solar power. The methodology for predicting solar power generation is as follows:

- Data collection; Data pre-processing; Data splitting: training and testing sets; Model training; Model testing and evaluation; Model comparison and selection; Simulation and result.

Solar PV cleaning system

The amount of power generated by solar systems heavily relies on the cleanliness of solar panels as well as the intensity of sunlight. Hence, it is crucial to clean solar panels regularly to ensure the efficient operation of the solar system. Dust particles must not get stuck on the panels, as they can damage them.

VSI and COEP are working together on this project to create an effective solar panel cleaning system. The

objectives of the project include studying different cleaning methods for solar panels, roof sheets, and RCC rooftops, ensuring ease of use, and estimating financial payback. The proposed design for the solar panel cleaning system has been finalized, and they are currently developing a prototype model to demonstrate its functionality.

Design of a solar panel cleaning system

The cleaning of solar panels is crucial for maintaining their efficiency and ensuring optimal energy production. One effective cleaning system is a pneumatic-hydraulic wiper roller system, which combines air-based (pneumatic) and water-based (hydraulic) components to achieve efficient cleaning. This system involves three main components:

1. An air blower for pneumatic action,
2. A water pump and pipe for water flow, and a wiper attached to a roller to wipe off water and debris, leaving the solar panels spotless.

The pneumatic-hydraulic wiper roller system for solar panel cleaning combines the benefits of pneumatic and hydraulic actions, providing an automated and effective cleaning solution. Compared to other systems, it offers efficiency, gentleness, and cost-effectiveness, making it a viable choice for maintaining solar panel efficiency and prolonging their operational life. Fig. 1 shows a block diagram of a prototype model of solar PV panel cleaning. It consists of a DC motor, wiper, PVC pipe, water tank, ball valve, air compressor, Arduino, and motor driver.

Block Diagram

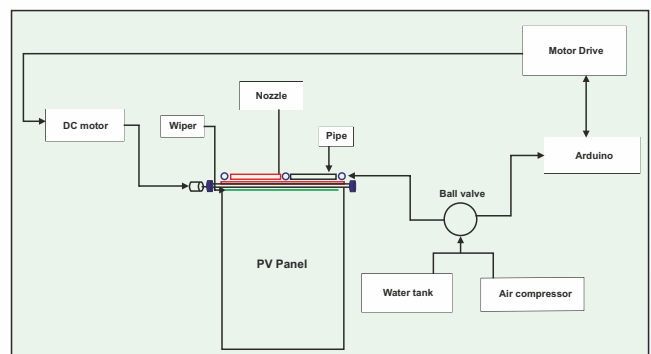
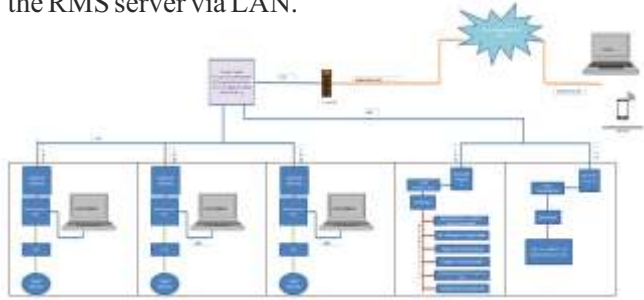

Fig. 1: Block diagram of proposed system

Analysis of data collected by remote advisory systems and machine learning

Precise and timely communication is vital in the operation and maintenance of integrated sugar complexes in the ultramodern world. Keeping in view of the same, the department has carried out the study on “Remote Monitoring and Advisory System” to monitor sugar mill and co-generation operating data remotely and to alert the concerned when there is any deviation in the process parameters so as to take appropriate corrective action in reducing losses and down time. The advisory system compares real-time data from the mill, boiler, turbine, electrical, and boiling house with design data for corrective action, if any, at the site.

At present, VSI/Stretto is setting up server-grade computers for this purpose. With its internet information server (IIS) functionality, monitoring of screens using standard HTML format from any mobile, tablet, or PC is possible. Data is collected on separate computers using OPC connectivity for process parameters without disturbing the running DCS system. Secured Internet connectivity is established using the firewall. This data was made available online for monitoring. The daily manufacturing data (DMR) and some manual data are also to be communicated to the RMS server via LAN.



Advisor is an internet-based or cloud-based application that is viewed remotely on a mobile (android or iPhone) or tablet, or on a laptop or personal computer. Now the selected process parameters are displayed along with a mimic display (real-time data display updating values instantaneously) for the mill section, boiler section, and turbine section using the Schneider Aveva Plant SCADA platform. Hence, new software development is being done using plant SCADA. This has functionalities for trends, alarms, and notifications via email, SMS, and events, with real-time data availability over the Internet. Later in the next stage, the same data will be connected to other

additional software for analytics, asset performance, preventive maintenance and predictive maintenance.

To study and implement a mechanism for cleaning and handling of manually or mechanically harvested sugarcane

In this project, various sugarcane harvesting methods, including manual and mechanical harvesting were studied along with their respective advantages, disadvantages and limitations. Additionally, we've examined the impact of extraneous matter or trash on sugar plant operation and performance, factors contributing to an increase in the quantity of extraneous matter or trash and losses incurred due to extraneous matter were examined. In India, sugarcane harvesting occurs at different stages, typically ranging from 10 to 18 months, depending on crop maturity and planting time. However, sugar mills often face labor shortages, leading to delays and reduced sugar yields and capacity utilization. To address this, many mills are turning to mechanical cane harvesters.

Mechanical harvesting is poised to become the future of sugarcane harvesting. As noted, extraneous matter or trash present in sugarcane can cause adverse effects during the milling and sugar manufacturing process. Therefore, it is crucial to clean sugarcane as much as possible to remove such extraneous matter or trash. Measures to mitigate losses in mechanical sugarcane harvesting involve effective cleaning systems to remove extraneous matter. These include,

- Sand removal system: mechanically unloading cane at mill yards and removing soil and rocks.
- Wet cleaning system: flooding carriers with warm water or using agitating conveyors with water jets and combing drums to remove debris.
- Dry cleaning system: utilizing equipment to reduce extraneous matter without water washing, though requiring higher capital, maintenance, and operational costs.

VSI personnel also visited a sugar mill in Mauritius to study their cane cleaning system, which include:

- Dry Cleaning System Methods
- Sugarcane leaf stripping
- By injecting forced air into the sugarcane curtain
- Wet Cleaning System



Study of spent wash incineration technology vs. spent wash drying technology for different types of feed to distilleries, like syrup, B-heavy and C-molasses

India's National Policy on Biofuels (2018) targets 20% ethanol blending in petrol by 2030. However, ethanol production generates distillery spent wash (DSW), which is treated using various methods such as anaerobic, aerobic, and electrochemical treatments. Incineration with coal or bagasse (as a fuel) fulfills energy needs. DSW can be used as an organic fertilizer after drying.

After the generation of raw spent wash from distilleries, it undergoes concentration in a Multi-Effect Evaporator (MEE) and is then incinerated in a boiler using the incineration route.

Another method involves drying the raw spent wash, where methane gas is generated through bio-methanation. The spent wash is then concentrated and dried to form a powder.

For the selection of incineration and dryer technology, it is necessary to study the details of both technologies and their techno-economic aspects.

The detailed study involved visiting industries where both ZLD technologies were adopted. The ZLD technology was evaluated on the basis of parameters such as approximate space requirement, duration for project installation, equipment content in the technology, steam, power, and condensate balance, performance parameters, installation cost, operation cost, manpower required, financial analysis, other merits and demerits, etc.

The technical team has examined the incineration boilers across several units and recorded observations on its constructional features and parameters. They will conduct a detailed study of drying technology by visiting industries where it is installed and evaluating it based on various parameters. Next, a comparison of both technologies will be carried out, taking into account their constructional and operational parameters, merits, and demerits.

Slip power recovery system in the slip ring motor

SRIMs are popular in the sugar, steel, and cement industries for starting and driving large inertia

applications. Maharashtra Sugar Industry has 250 SRIM installations for fibrizer, leveler, and chopper applications. SRIM is used for non-uniform load patterns, and the tentative standard rating for fibrizer application is an average of 1000 to 2500 kW in sugar mills.

In the present scenario, the SRIM motor, tentatively with a 2000 kW rating, is being driven by two methods, which are LRS (liquid resistance starter) and ASR (automatic resistance with slip regulator).

Though the slip ring motor with LRS/ASR starters offers the required torque for fibrizer application, it has the drawback of continuous power loss in the form of heat in rotor resistance depending upon the slip percentage, and this power loss is termed slip power.

The approximate average power loss in the LRS method is around 5-6%, i.e., 100-120 kW, and in the ASR method, it is around 1-2.5%, i.e., 20-50 kW.

This power loss is not useful for doing any work. In this project, we will explore the potential of power loss recovery in the slip ring motor with LRS and ASR in combination with a slip power recovery system.

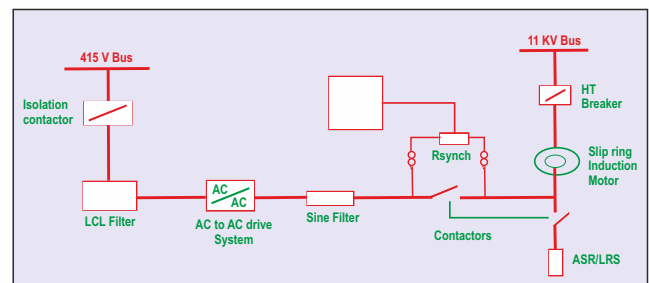

The SPR system consists of an AC drive (interconnected converters and inverters) along with a synchronizing system.

The AC drive is connected to the three-phase rotor winding of SRIM. The feedback power will be given to the 415-volt power system through SPRS. The slip power from the fibrizer SRIM can be recovered and fed back to the AC source so as to utilize it outside the motor. Thus, the overall efficiency of the drive system can be increased.

Work progress

- Visits have been given at various plants that have fibrizers with higher-rated slip ring motors and liquid resistance starters or auto-slip regulator starters.

- Accordingly, visits were given to the following plants having mostly of following type;
 1. 1500 kW slip ring motor with ASR.
 2. 2000 kW slip ring motor with LRS.

Various readings were taken at the site on fibrizer starters. To assess the slip power loss in the system, different readings like rotor voltage, rotor current on the rotor side, stator voltage on the stator side, motor running rpm, and power factor are to be measured after every 5-minute period for one hour in each shift with the help of a power analyser in different sugar mills. After analysing the observations and economical calculations, we can assess the importance of replacing the LRS starter with an ASR or slip power recovery system.

EXTENSION AND ADVISORY SERVICES

The department provides a range of services, from the initial concept to the final commissioning of green-field and brown-field projects related to sugar mills, cogeneration, and distillery captive power projects. The department is responsible for preparing technologically feasible detailed project reports (DPR) for new projects and for the modernization and expansion of existing sugar mills. The department also deals with the installation of bagasse-based cogeneration systems and incineration boilers for generating steam and power to meet the captive requirements of the mills and export surplus power to the grid. In addition to preparing the DPR (Detailed Project Report), the department undertakes various project activities. This includes preparing bid documents, floating tenders, identifying suitable vendors, providing advisory services for scrutinizing designs and drawings, inspecting plant and machinery and supervising during erection and commissioning. Also prepare performance & valuation, rehabilitation and revival reports for sick sugar mills.

In the year 2023–24, the engineers of the department have paid 609 visits to various sugar mills, cogeneration plants, and distilleries for extension and advisory services, review project activities, evaluated and improve the overall performance of sugar mills and assess cogeneration systems (including those based on bagasse and incineration). The engineers paid special

attention for stabilizing the concerned mills, conserving energy, and optimizing utilities such as steam, power and water. The department also carried out scheduled technical audits to enhance the technical performance of juice extraction, sugar manufacturing, steam & power generation and water management.

The department engineers assisted the management in selecting the managing directors, general managers, works managers, chief engineers and shop-floor engineers by conducting interviews.

Below are the notable achievements and success stories of the department during the year 2023–24 that highlight the engineers' contribution towards enhancing the technical performance of the sugar mills, as well as the successful implementation of capacity expansion and modernization projects.

KAT Samarth SSK, Unit-I

To mitigate the problem of surplus sugarcane in the area of operation, sugar mill management took the decision to expand the capacity of the existing sugar plant from 4000 TCD to 7500 TCD under the guidance of VSI. During the preparation of DPR, the additional cane crushing capacity of 3500 TCD was considered for the production of ethanol to support national bio-fuel policy.

Major modifications were made to the equipment, including a parallel milling tandem of 42" x 84" x 04 mills, bagasse handling system, juice concentration house with 1500 m² HS evaporator bodies in a quadruple set configuration, and a 150 KLPD capacity distillery plant. To meet the demand for steam and power, the existing old boilers were revamped with modifications and proper maintenance and operated to reduce the cost of the project.

The plant is running successfully after expansion with enhanced results, which are as follows:

- The crushing rate increased from 4000 TCD to 9000 TCD.
- Process steam consumption of the juice concentration plant : 22% on cane
- Pol% Bagasse: reduced from 2.5 to 1.75.
- Moisture% Bagasse: reduced from 51% to 48%
- Bagasse savings increased up to 6.0% on cane.



Venkteshwara Power Project

To dispose of surplus sugarcane in the area of operation, sugar mill management carried out the expansion of the sugar mill from 8000 TCD to 12000 TCD, along with the expansion of cogeneration from 23 to 48 MW for additional revenue generation through surplus export power as per the DPR prepared by VSI.

The sugar mill has successfully erected and commissioned an expansion project along with the expansion of cogeneration during the ten-month period under the guidance of department engineers. The major addition/modification of equipment comprises mill house equipment such as a new auxiliary and main cane carrier having 3.0-metre-wide, the addition of feeding table and cane unloader, addition of the 1st three roller mill of size 50" x 100" with GRPF, the 6th two roller mills of size 50" x 100", the 5th mill with new and modified inter-carriers, parallel 5000 TCD capacity boiling house, and a 140 tph high-pressure boiler, matching 25 MW back pressure TG Set with auxiliaries. The plant is running successfully after expansion with the enhanced results, which are as follows:

- The crushing rate increased from 8000 TCD to 13000 TCD.
- Process steam consumption: reduced from 40% to 30% on cane
- Pol% Bagasse: reduced from 2.2 to 1.75.
- Moisture% Bagasse: reduced from 50 to 48%.
- Bagasse savings increased from 6% to 12% on cane.

Vilas SSK, Unit-I

The sugar mill was facing problems of not achieving performance and consistency in the crushing rate due to inadequate plant and machinery capacity. Considering the same, sugar mill management approached VSI for the modernization of sugar mill to mitigate the said problems.

The sugar mill has successfully erected and commissioned a modernized sugar mill for 3500 TCD under the guidance of VSI. The major additions and modifications to equipment include mill house equipment such as two conventional mills of size ϕ 40" x 80" used as the 1st and 5th mills with new drives and inter-carriers, boiling house equipment such as

4000 m² HS FFE, 1500 m² HS, 900 m² HS, 600 m² HS RB, and a 36' diameter clarifier. The plant is running successfully after modernization with enhanced results are as follows:

- The crushing rate: increased from 4000 to 4592 TCD.
- Process steam consumption: reduced from 44.50% to 38.0% on cane
- Pol% Bagasse: reduced from 2.04 to 1.9.
- Moisture% Bagasse: reduced from 50.13 to 50.04.
- Bagasse savings increased up to 3.0% on cane.

Vilas SSK, Unit-II

The sugar mill was facing problems with consistency in the crushing rate due to frequent mill stoppages. For stabilizing the crushing rate and improving performance, the following suggestions were implemented during the off-season under the guidance of VSI:

- The existing fixed-type leveller was converted into a swing type along with the addition of a 250-HP drive to the other side or end.
- The auto-cane feeding system was fine-tuned.
- TRPF with TUFR of first and last mills maintenance done during off-season
- After implementation of said suggestions during crushing season 2023–24, the average crushing rate improved from 3006 TCD to 3549 TCD.

Rena SSK

The sugar mill management was very keen to enhance the crushing rate also to handle of surplus sugarcane in the area of operation to improve existing sugar mill performance so as to reduce fixed costs and generate additional revenue. Accordingly, VSI prepared the DPR for modernization and expansion of the sugar plant from 2500 TCD to 4950 TCD.

As per the DPR, the sugar mill implemented the first phase of expansion in the mill house in the season 2022–23. The major additions comprise mill house equipment such as a cane carrier of 1830 mm width, a suitable chopper, leveller, fibrizer, FRC, mills of size 36" x 72" (02 nos.) with GRPF, and an elevator. This first phase was successfully commissioned in the season 2022–23.

The second phase of expansion was carried out in the boiling house in the season 2023–24. It comprises addition of boiling house equipment such as 4000 m² HS FFE, 1500 m² HS, 900 m² HS, and 600 m² HS Robert bodies, 30' diameter clarifier, 10' x 20' RVF, batch pan, and continuous centrifugal machines. The second-phase project was successfully commissioned in the season 2023–24 under the guidance of VSI and running successfully. After the completion of both phases, the average crushing rate improved from 3369 TCD to 4325 TCD, and the steam consumption was reduced from 51% to 48% on cane.

Manjara SSK

The sugar mill was facing a low recovery problem. During the visit, suggestions were given regarding corrective resetting of the mill and the fibrizer discharge opening and also suggested for applying and increasing hot water imbibition up to 28–30% on the cane at a temperature of 82–85°C. The suggestions helped to reduce pol and moisture content of bagasse, resulting in improved recovery in the sugar mill.

Shree Datta Shetkari SSK

The sugar mill management approached VSI for the preparation of the DPR for modernization and expansion from 7000 TCD to 12000 TCD for enhancing existing plant and machinery capacity as well as performance.

Accordingly, as per DPR of the sugar mill carried out an expansion in the season 2022–23. It comprises mill house equipment such as Cane carrier of 2500mm width, suitable chopper, leveller, fibrizer, FRC, IRC, mills of size 50" x 100'-02 nos., belt conveyor, elevator, pump, and piping, and boiling house equipment's such as 7500 m² HS FFE-04 no's to achieve steam percentage cane 33, juice heaters, pans, crystallizers, and centrifugal machines. This project was successfully commissioned in the season 2022–23 under the guidance of VSI and was running successfully with an improvement in the average crushing rate from 8286 TCD to 9772 TCD.

During the 2023–24 seasons, after overcoming the teething problems, the average crushing rate improved from 9772 TCD to 11132 TCD and the bagasse saved on cane increased from 3.50% to 7%, while the steam used in the process decreased from 40.85% to 35.24% on cane.

Also provided guidance for the incineration boiler, and the TG set comprises a 25 tph boiler operating at 45kg/cm² pressure and 400°C temperature with a matching TG set of 2.5 MW BP type for disposal of spent wash and to meet the captive power consumption for their 60+60 KLPD distillery plant project. This project was successfully commissioned in the season 2023–24 under the guidance of VSI and is running successfully.

Loknete Balasaheb Desai SSK

The sugar mill had an initial crushing capacity of 1250 TCD and was running with old and outdated technology machinery. Due to that, it incurred losses and was unable to achieve the desired performance. Considering the same sugar mill management approached VSI for modernization and expansion of the sugar plant mill from 1250 TCD to 3000 TCD.

Accordingly, as per the DPR, the sugar mill has successfully modernized and expanded its plant under the guidance of VSI. The major addition or modification of equipment comprises mill house equipment such as increased the depth of the existing cane carrier by 100 mm; modify the existing fibrizer with a swing diameter of 2150 mm; added two motions cane unloader: a sling type 12.5 tonne SWL capacity bridge (designed for 2 # 12.5 tonne capacity trollies); installed one # 12.5t capacity double drum trolley with a de-hooking system remote type; added one feeding table (6 meter wide x 7 meter length; 2 nos.); added one new mill of 33" x 66" size with TRPF; rake type intermediate carrier (3 nos.); and boiler house equipment's. The plant is running successfully after expansion with enhanced results, which are as follows:

- The crushing capacity increased from 1250 TCD to 2740 TCD.
- Process steam consumption: reduced from 52.0% to 42% on cane
- Pol% Bagasse: reduced from 3.0 to 1.9.
- Moisture% Bagasse: reduced from 52 to 49-50.
- Bagasse saving: increased up to 5.0% on cane.

Shri Vighnagar SSK

The sugar mill proposed to install a 65 KLPD distillery plant to support national biofuel policy as per the DPR prepared by VSI. To dispose of waste



generated in distillery operations and achieve zero liquid discharge, the department provided the guidance for installation of a 25 tph capacity incineration boiler matching with a 2 MW BP type TG set for captive power consumption. With strategic planning and close coordination with the vendor, the sugar mill has been able to erect and commission the boiler with supporting fuel (coal and bagasse) along with a 2 MW BP-type TG set under the guidance of VSI.

Karmveer Shankarrao Kale SSK

The sugar mill had an initial crushing capacity of 2500 TCD and was running with old and outdated technology machinery with a crushing capacity of 4000 to 4500 TCD. Due to that, it incurred losses and was also unable to achieve the desired performance. Considering the same; sugar mill, management taken the decision to modernize the sugar mill along with balancing machinery for 4500 TCD crushing capacity in a phase-wise manner due to space constraints in the sugar mill premises for the addition of machinery.

VSI prepared the DPR for the first phase of modernization to replace existing milling tandems with the latest technology milling tandem and it was successfully implemented during 2022–23. After phase-I modernization, management took the decision to implement modernization of process house machinery in place of the discarded mill house area.

Accordingly, for modernization phase II, work like preparation of DPR, statutory approval, invitation of tenders, technical comparison of tenders, commercial bid process, and purchase agreement completed during crushing season 2022–23.

In the off-season preparation of layout, scrutiny of drawings, erection work, etc., activities were carried out. Old and inefficient equipments were replaced by modern equipment like falling film evaporators having heating surface (m^2) : 4000 x 5 Nos., Syrup Clarification Plant, Auto pH Control System, Low Head Vacuum Pan 100tonne capacity with mechanical circulator x 05 Nos. 80 tonne capacity, 4 Nos., molasses conditioner with auto-brix and temperature control, A simplex-type automatic weighing machine of 200 bags per hour of 50 kg and a stitching machine. Waste heat recovery devices like vapour line juice heaters (350 m^2 heating surface x No.), condensate juice heaters, and flash heat recovery systems also installed.

Direct-contact juice heater installed for clear juice heating. The modernization project (Phase II) was successfully commissioned in November 2023. The major achievements of project phase I and II are as follows:

- The average crushing rate increased from 3970 TCD to 5330 TCD.
- Reduced mill extraction: improved from 95.82 to 96.02.
- Power consumption: reduced from 24.23 to 23.5 kWh/tonne of cane
- Process steam consumption: reduced from 40.87% to 34.0% on cane
- Boiling House recovery: improved from 88.67 to 89.01.
- Sugar colour: improved from 110 IU to 65 IU.
- Bagasse saving: increased up to 8.0% on cane

Ashok SSK

The incineration boiler and TG set comprise a 22 tph boiler operating at pressure 45kg/cm² and temperature 400°C with a matching TG set of 2.0 MW BP type was installed for disposal of spent wash and to meet the captive power consumption for their 60 KLPD distillery plant project. This project was successfully commissioned in the season 2023–24 under the guidance of VSI.

Rajarambapu Patil SSK

The sugar mill successfully commissioned a captive power plant for the expanded 150KLPD distillery project comprising of an incineration boiler of 32 tph, pressure 45 kg/cm²(g), temperature 400°C, (spent wash with coal & bagasse as supporting fuel) with matching 3.0 MW BP type TG set in December 2023 under the guidance of VSI.

Venkateshkrupa Sugar Mills

Under the guidance of VSI, the sugar mill has erected and commissioned a new 240 KLPD distillery project. To meet 240 KLPD the captive steam and power demand sugar mill revamped the existing bagasse-fired boiler from 40 to 50 tph with a pressure of 45kg/cm² (g) and a temperature of 500°C and installed a 5 MW TG set with 4.0kg/cm² (g) exhaust pressure suitable for distillery operations. The project was successfully commissioned in the season 2023–24.

The sugar mill has successfully balanced its capacity for 5000 TCD during the off-season 2023–24 under VSI guidance. The major addition/modification of equipment comprises mill house equipment such as auxiliary cane carrier of 2300 mm width, a 60 T capacity fixed-type truck tippler, a TRF system, a discharge roller drive with gearbox for existing 2nd, 3rd, and 4th mills, an IRC of 2140 mm wide for the 2nd and 3rd mills, one new two-roller mill of 42” x 84” size with an IRC and 750 kW drive, etc. The plant is running successfully after expansion, with enhanced results in season 2023–24, which are as follows:

- The crushing rate is balanced for 5000 TCD.
- Pol% Bagasse : reduced from 2.56 to 1.81.
- Moisture% Bagasse : reduced from 50.48 to 48.28.
- Mill extraction : increased from 95.53 to 96.41.

Detailed project reports and proposals

The department was involved in preparing the green field, modernization, expansion, co-generation, distillery captive power projects, and valuation, rehabilitation, and revival reports for sick sugar mills.

Greenfield sugar projects

The following Greenfield project reports for sugar mills were prepared and details given in table 1.

Modernization proposals

Modernization proposals were prepared for the following sugar mills to reduce steam and captive

power consumption while enhancing the exportable power from co-generation plants. Also, emphasis was given for improving technical performance and enhancing capacity utilization and details given in table 2.

Expansion proposals

The department prepared Detailed Project Reports for the expansion of the following sugar mills is given in table 3

By-product proposals/projects

The department prepared co-generation DPRs and tender documents for boilers, TG sets, balance of plant and electrical interfacing equipment in co-generation and distillery projects. Additionally, the erection and commissioning of the following co-generation and distillery projects were also monitored.



Governing Council Meeting at VSI

Table 1: DPR for Green Field Sugar Projects

Name of Mill	Capacity of Plants (TCD)	Project Status
Sankalp Green Power	4000	DPR Submitted
Sankalp Green Power	4500 (Revised)	DPR Submitted
SP Sugar & Agro	3500 (Revised)	DPR Submitted
Swami Samarth Sugar and Agro Industries	4000	The project is under execution.

Table 2: Modernization proposals

Name of Mill	Modernization (TCD)	Project Status
Chhatrapati Rajaram, SSK	3500	DPR Submitted
Shree Ukai Pradesh SKUM	2500	DPR Submitted
Mohanrao Shide SSK	4500	DPR and Tender Submitted
Project commissioned		
Vilas SSK Unit I	3500	Project Commissioned
KS Kale SSK	5500	Project Commissioned



Table 3: DPR for expansion of sugar mills

Name of Mill	Modernization Cum Expansion (TCD)
DPR Submitted	
Sharayu Agro Industries	5000 to 7500
Yedeshwari Agro Products	2500 to 6000
KAT Samarth SSK Unit-I	4000 to 7500
Vilas SSK Unit-II	2500 to 4900
Loknete Balasaheb Desai SSK	1250 to 3000 (Phase-II)
Ambalika Sugar	12000 to 17000
Shri Vighnagar SSK	5000 to 7500
Anuraj Sugar	2500 to 3500
DDN SFA Unit-II, Kalamb	1250 to 4000
Tender technical specifications submitted	
RP Ghodganga SSK	Tenders for mill house equipment for expansion work
Shri Vighnagar SSK	Tender documents submitted
Projects Commissioned	
KAT Samarth SSK Unit-I	4000 to 7500
Vilas SSK Unit-II	2500 to 4900
Sonhira SSK	5000 to 9500
Rena SSK	2500 to 4950
Dr. PK Sonhira SSK	5000 to 9500
KS Kale SSK	3500 to 4500

a) Co-generation proposals

The status of co-generation project proposals is given as below in table 4.

b) Distillery captive power projects

The status of distillery captive power projects are as given in table 5.

Table 4: Details of co-generation project proposals

Name of Sugar Mill	TCD	Co-gen.Capacity (MW)	Boiler Cap. (tph)/ pressure (kg/cm ² (g))/ temp. (°C)	TG Cap. (MW)/ Type BP/DEC
DPR Submitted				
Yedeshwari Agro Products	6000	28	60/73/515 (existing) 100/73/515 (new)	10 BP (existing) 18 Ex. BP (new)
Sankalp Green Power	4000	15	100/73/515	18 BP
Chhatrapati Rajaram, SSK	3500	18.5	110/87/520	18.5/BP
Shree Sayan Vibhag SKUM	6900	23	140/87/515	23/BP
DDN SFA Unit II	4000	15	70/45/485 (existing) 40/45/485 (new)	3BP (existing) 12 BP (new)
Projects under execution				
Ambalika Sugar	17000	18	100/110/540	18/BP
Swami Samarth Sugar and Agro Industries	4000	14	80/87/510	14/BP

Table 5: Distillery captive power projects

Name of Sugar Mill	Capacity (KLPD)	Boiler Capacity (tph) /Pressure (kg/cm ² (g)) / Temp. (°C)	TG set Capacity (MW/Type)
Projects Commissioned			
Shree Datta SSK	60 + 60	25/45/400 (Incineration)	2.5/BP
Vilas SSK Unit II	60	20 /45/490 (Conventional)	2/BP
Shri Vighnahr SSK	Expanded distillery 65	25/45/400 (Incineration)	2 /BP
Ashok SSK	60	22/45/400 (Incineration)	2 /BP
Rajarambapu Patil SSK Unit I	150 (Expanded distillery)	32/45/400 (Incineration)	3.0/BP
Venkateshkrupa Sugar Mills	240	50 /45/500 (Up-gradation of existing Conventional)	5/BP
Tender/DPR technical specifications submitted			
Padmabhushan Krantiveer Dr. Nagnathanna Nayakwadi Hutatma Kisan Ahir SSK	100	30/45/440	3.0 BP
Anuraj Sugar	45	25/45/440 (Conventional)	2.5 BP
Yoki Green Energy	100	32/45/440 (Conventional)	3.0 BP
Projects under execution			
Rena SSK	30 + 30	20/45/440 (Existing)	2.5 /BP
Ambalika Sugar	250	65/45/400	6.5 /BP
LMGP Dnyaneshwar SSK	45 + 55	32/45/400 (Incineration)	3.4/BP
Shri SantTukaram SSK	45	16/45/400 (Incineration)	1.5/BP

c) Other reports for financial assistance from MSC Bank / NCDC

The department prepared various status reports for NCDC - Loan & other reports of following sugar mills Status reports for NCDC Loan: Status report of following 22 sugar mills prepared as per directives of Commissioner of Sugar and submitted.

Shri Chhatrapati SSK, Jai Bhawani SSK, Shri Sant Kurmdas SSK, Sahkar Shiromani Vasantrao Kale SSK, Bhaurao Chavan SSK Unit-I, Bhaurao Chavan SSK

Unit II, Raosaheb Pawar Ghodganga SSK, Loknete Marutrao Ghule Patil Dnyaneshwar SSK, Rajgad SSK, Mula SSK, Shri Sant Damaji SSK, Swami Samarth SSK, Karmyogi Kundalikrao Ramrao Jagtap Patil Kukadi SSK, Loknete Sunderraoji Solanke SSK, Agasti SSK, Kisanveer Satara SSK, Kisanveer Khandala Sahakari Sakhar Udyog, Shri Vridheshwar SSK, Padmabhushan Krantiveer Dr. Naganathanna Nayakwadi Hutatma Kisan Ahir SSK, Vishwasrao Naik SSK, Shri Siddheshwar SSK and Shri Ambejogai SSK

Other reports: is given in table 6

Table 6 : Other reports

Name of Mill	Details of Reports
Shri Makai SSK	Revaluation of plant & machinery
Shree Halsiddnath SSKN	Assessment of plant and machinery for 8500 TCD capacity
Shri SantTukaram SSK	Sugar plant cost overrun report
Swami Samarth SSK	Present Status Report of sugar mill execution work
Siddheshwar SSK	Present Report of the Existing RCC Chimney of the 3 rd and 4 th boiler suitably by extending the flue gas duct from the 200 tph boiler
Sant Damaji SSK	Machinery/Equipment/Refurbishment for 5000 TCD / 24 hrs.



Consultancy to Non-Member Sugar mills

The department provided consultancy to following non-member sugar mills for improving the technical performance as given in table 7.

Interviews conducted for the selection of technical personnel

VSI engineers visited the following sugar mills for the selection of Managing Director, Technical Advisor, General Manager, Co-generation Manager, Chief Engineer, Chief Chemist, Engineers, and other operational staff, etc.

Athani Sugar, Karnataka, S. Nijalanggappa Sugar Institute, Karnataka, Nandi SSKN, Karnataka, Shree Datta SSK, Vilas SSK Unit-I, Vilas SSK Unit-II, Malegaon SSK, Loknate Blasaheb Desai SSK, Belgaum Sugar, Karnataka, Pandurang SSK, Manjara SSK, Aayan Multitrade LLP, Quienergy Industries, Agasti SSK, Sahakar Maharshi Shankarrao Kolhe SSK and Sharad SSK

Topping cycle ratio certification

The department has scrutinized the topping cycle documents and issued certificates to the following sugar mills.

Piyush Sugar and Power, Chhatrapati Rajaram SSK, Panchaganga Sugar & Power, Onkar Sakhar Karkhana, Rayat Unit - Athani Sugar, Sonai Etable India, N D Patil Sugars and Shri Ambalika Sugar.

Preparation of tender technical specifications for plant and machinery

Tender technical specifications of machinery and equipment were prepared for the following sugar mills.

KAT Samarth SSK Unit-I

1000 m² HS rising film evaporator (Semi Kestner), 300 m² HS condensate juice heater, 100 kg/hr capacity x 2 nos sulphur burner, 60HL capacity syrup sulphiter, 100tonne capacity x 2 nos batch type vacuum pans, (B & C)-25/15 tonne capacity twin continuous vacuum pans, 110 tonne capacity x 3 nos air cooled crystallizers, 60 tonne capacity x 2 nos vacuum crystallizers, 1750 kg/charge capacity x 2 nos batch type centrifugal machines, 1500 kg x 4nos continuous type centrifugal machines, 20 t/hr capacity sugar melter, 2 meter width x 12 meter length x 3 nos sugar hoppers, 40 t/hr capacity sugar elevator, 35 t/hr capacity sugar grader, 100 tonne capacity x 2 nos and 50 tonne capacity x1 nos sugar silos.

PKDNN Hutatma Kisan Ahir SSK

30 tph capacity multi fuel boiler with 45 Kg/cm² pressure and 440⁰C super-heated steam temperature Multi-fuel boiler, 3.0 MW and 8.0 MW TG matching sets, 15 t/hr capacity bagasse handling, Ash handling, LP and HP Steam piping, DCS system.

Vilas SSK Unit-II

2100 mm swing diameter fibrizer along with 1700 mm width and 120 nos hammers, 48 knives swing type cane leveler, 2030 mm FRC width and 55 kW drive, 30 tonne

Table 7: Consultancy to non-member sugar mills

Name of Mill	State	Details
Shree Manjra Sugar Industries, Mangrul	Maharashtra	Review and improvement of performance
Bhoramdeo Sahakari Shakkar Utpadak Karkhana Mydt	Chhattisgarh	Equipment / Machinery required for expansion up to 5000 TCD crushing capacity.
MRN Cane Power (India)	Karnataka	Performance assessment of sugar plant.
Shree Kedarnath Sugar & Agro Products	Karnataka	Performance assessment of sugar plant.
Badami Sugars	Karnataka	Performance assessment of sugar plant.
MRN Group (Sai priya, Nirani, Bhima Patas)	Maharashtra	Review and improvement of performance
Vasant SSK (Lease by Bhairavnath Sugar Works)	Maharashtra	Off-season maintenance work.
Saipriya Sugar	Karnataka	Checking Technical performance
Nirani Sugar	Karnataka	Checking Technical performance
Shree Sayan Vibhag SKUM	Gujarat	Checking Technical performance

capacity mill house EOT crane, 1020 mm x 2040 mm size mill with TRPF, 8 MW TG set bleed cum back pressure turbine complete with casing, rotor, blading, bearings and glands, 400 m² HS x 02 nos condensate juice heaters, 26' diameter clarifier, 10' x 20' size rotary vacuum filter, 3000 m² HS, 2000 m² HS, 1500 m² HS and 1000 m² HS Robert type evaporator bodies, 80 tonne capacity batch type vacuum pan, 90 tonne capacity air cooled crystallizer, 40 t/hr capacity sugar elevator, 35 t/hr capacity sugar grader, 100 tonne capacity sugar silo.

Shree Narmada KUSM, Dharikheda

120 tph capacity bagasse fired boiler, 87 kg/cm² pressure and 520°C superheated steam temperature, 20 MW bleed cum BP type TG set 85 kg/cm² pressure, 515°C temperature, 10 MW DEC type TG set for matching 45 kg/cm² pressure and 485°C temperature, 33 tph capacity air cooled condenser, 30m³/hr capacity RO plant followed by DM plant with ultra-filtration system, 75 tph capacity fuel handling system, Three field ESP, 80 m³/hr capacity transfer pumps, 70 m³/hr capacity feed water pumps, LP and HP steam piping, 70 m³/sec capacity x 2 nos ID fans, 30 m³/sec capacity x 2 nos FD fans, Boiler MCC and PCC panels, 20 mVA generator transformer and 11/66 kV switch yard, 4 mVA distribution transformers for plant electrical distribution system

Chhatrapati Rajaram SSK

12.5 tonne capacity two cane unloading trolleys, 2040 mm width, 1500 mm slanting height cane carrier, 1600 mm swing diameter x 2040 mm width and 48 knives chopper, 1600 mm swing diameter x 2040 mm width, 52 knives cane leveler, 2200 mm Swing diameter x 2040 mm width, 152 hammers fibrizer, 2030 mm rake width along with 5 kW drive FRC, 30 tonne capacity mill house EOT crane, 1020 mm x 2040 mm size mill with TRPF, 700 kW AC-VFD drive/1020 mm x 2040 mm size two roller CMR mill with three roller TRF, 700 kW AC-VFD drive, 325 m 2HS x 02 nos for SJ heater, 240 HL capacity juice sulphiter, 95HL capacity syrup sulphiter, 20' diameter clarifier, 1800 m² HS and 1000 m² HS Robert bodies, 30 tph and 18 tph capacity continuous pans, 1750 kg/charge capacity batch centrifugal machine, 1500 mm diameter-continuous machine for B - massecuite, 3.5 mVA distribution transformer of 11 kV/433V, 2 mVA capacity x 2 nos converter transformers of 11 kV / 690 V, 110 tph capacity boiler

bagasse fired boiler, 87 kg/cm² pressure and 520°C temperature, 18.5 MW Bleed cum BP type matching TG, 30 m³/hr capacity RO plant followed by DM plant with ultra-filtration system, 75 tph capacity fuel handling system, Three field ESP, 70 m³/hr capacity transfer pumps, 65 m³/hr capacity feed water pumps, 30% margin in capacity and 25% margin in head for ID & FD fans, Boiler MCC and PCC panels, 20 mVA generator transformer for 11/110 kV switch yard, 2.5 mVA capacity x 02 Nos. distribution transformer for plant electrical distribution system.

Mohanrao Shinde SSK

Existing plant modifications to suit the installation of the new distillery consisting of IBR piping for the distillery and modifications in the existing process house, 45 KLPD (CHM)/60 KLPD (Syrup/BHM) distillery plant electrical part

Shri Vighnahar SSK

25 tph capacity incineration boiler, 45 kg/cm² pressure and 400°C superheated steam temperature, 2.0 MW BP type matching TG set, ID, FD & SA fans, 7.5 tph capacity coal handling system, Bagasse handling system, 5 tph capacity dump condenser, 250 kg/hr capacity continuous sulphur burner with heat recovery system, 120 tonne capacity batch type vacuum pan, 130 tonne capacity air cooled crystallizer GA, 6.5 MW BP TG set, 35 to 50 tph boiler capacity enhancements of existing 2 nos boilers, 6 MW back pressure type TG set

Loknate Balasaheb Desai SSK

2150 mm swing diameter fibrizer, 12.5 tonne capacity cane unloader, 6 meter width x 7 meter length Feeder table, 33" x 66" size mill with TRPF, Rake type inter rake carrier, 200 m²H Stubular juice heaters x 3 nos, 26' juice clarifier addition of 5th compartment, 60 tonne capacity batch vacuum pan 65 tonne capacity air-cooled crystallizer, 30 tph capacity grader, 30 tonne capacity weighbridge, 12.50 tonne capacity cane unloader, 6 meter width x 7 meter in length size feeder table 1600 mm swing diameter cane leveller, 33" x 66" mill with TRPF with 1st mill, 1800 mm diameter x 3600 mm length sizerotary juice screen, Bagasse elevator modification, Return bagasse carrier modification, 20 to 35 tph boiler capacity revamping, 21 kg/cm² pressure, 300°C superheated steam temperature, 20 tonne/ 5 tonne capacity power house crane, Electric panels & VCB panels, 250 kVA capacity DG set, 50tph capacity PRDS 21 kg/cm² to 1.5 kg/cm².



Ajinkyatara SSK

40 tph capacity boiler 67 kg/cm²(g) pressure 510 ± 5°C temperature, 6.5 MW matching TG Set,

Shri Sant Tukaram SSK

16 ph capacity incineration boiler, 45 kg/cm²(g) pressure, 400°C temperature, 1.5 MW BP type matching TG set, 10 tph capacity bagasse handling, DCS system, 7.5 tonne capacity EOT crane, 7 tph capacity dump condenser, 700 m³/hr capacity cooling tower, Electrical system

Scrutiny of design and drawing of equipment

Scrutiny of design and drawing of equipment for the following mills were carried out.

KAT Samarth SSK Unit-I

Bagasse handling system, 2200 mm width bagasse elevator, 1600 mm width belt conveyor BC1, BC2 and BC3, 14'' x 28' vacuum filter, 40' diameter clarifier (4-4-4)

Vilas SSK Unit-I

40'' x 80'' size x 02 Nos. mills layout, Process house layout, Boiling house equipment, 350 m² HS juice heaters, 4000 m² HSFFE, 1500 m² HS, 900 m² HS and 600 m² HS Robert bodies, 36' diameter clarifier.

SM Shankarrao Mohite Patil SSK

8000 tonne capacity molasses storage tank

Vitthalrao Shinde SSK Unit-II

ø 36'' X 72'' size mill with GRPF for first mill, ø 33'' X 66'' mill modified layout

Swami Samarth Sugar and Agro

4000 TCD sugar plant layout, Technical specifications of pumps with pump curves

Loknate Balasaheb Desai SSK

33'' x 66'' mill with TRPF, Cane unloader, Feeder table, Cane carrier, Rotary juice screen, 200 m² HS tubular juice heater, 60 tonne capacity batch pan, 65 tonne capacity air-cooled crystallizer, 30 tonne capacity sugar garder, Sugar handling system, 1500 mm width auxiliary cane carrier, 1200 mm swing diameter cane chopper, 1600 mm swing diameter cane leveller, 1400 mm width FRC, Layout of mill station, MCC panels

LMGP Dnayneshwar SSK

32 tph capacity incineration boiler GA and P&ID,

150 NB HP and 300 NB LP steam piping, ESP layout, 5 liter/hr capacity LP dosing and 10lph capacity HP dosing system, 17 m³ /hr capacity slop transfer pump, 47 m³/sec capacity ID fan, 13 m³/sec capacity FD fan, 8.7 m³/sec capacity SA fan, 49 m³/hr capacity boiler feed pumps, 20 tph capacity bagasse handling system, 3.0 MW TG set power house layout and P & ID, 10 tonne power house EOT crane, 10 tph capacity dump condenser, 600 m³/hr and 150 m³/hr capacity cooling tower, Electrical panel rooms layout, Single line diagram (SLD), Control relay panels, PCC panel, VFD panels, Distillery and boiler MCC panels, Cable schedule, Electrical equipment data sheet

Shri Sant Tukaram SSK

16 tph capacity incineration boiler GA and P&ID, 10 tph bagasse handling system, Ash handling system, ESP layout, 19.82 m³/sec capacity ID, 5.79 m³/sec capacity FD and 3.86 m³/sec capacity SA fans, 22 m³/hr capacity boiler feed pumps, 1.5 MW TG set power house layout and P & ID, 7 tph capacity dump condenser, 700 m³ /Hr capacity cooling tower, Distillery MCC panel data sheet, Cable schedule, ESP TR set and TRCC panels, Ash handling MCC panel.

Rajarambapu Patil SSK Unit-I

Power house layout, panel rooms layout, SLD, Control relay panels, PCC Panel and VFD panels, Distillery and Boiler MCC panels, Cable schedule, Electrical equipment data sheet verifications

Venkateshkrupa Sugar Mills

42'' x 84'' size mill along with 2140 mm with IRC, 2300 mm width auxiliary cane carrier, 2200 mm width bagasse belt conveyors, power house layout, Panel rooms layout, SLD, control relay panels, HT panels, PCC panel, VFD panels, distillery and boiler MCC panels, Cable schedule, Electrical equipment data sheet verifications.

Ambalika Sugar

Switchyard equipment, 1250 kVA DG Set, 11 kV indoor ICOG, MCC panel.

Rena SSK

TG set SLD, Alternator data sheets, 11 kV HT panel, PCC SLD, MCC panels.

Swami Samarth Sugar & Agro Industries

15 mVA general transformer, 3.5 mVA distribution transformer, 1.5 mVA convertor transformer, 33 kV CRP panels, Switchyard equipment, Cable schedule, Earthing

layout, All MCC panels, Power house layout, HT panels, Cogen PCC panels.

Vilas SSK Unit-I

PCC panels, MCC panels.

Dr. PK Sonhira SSK

11 kV standalone panels, VFD panels, MCC panels, Cable schedule.

Inspection of machinery and equipment (including virtual)

Inspection of various machinery and equipment for following sugar mills was carried out.

KAT Samarth SSK Unit-I

42" X 84" size x 04 nos mills, 1800 mm x 3600 mm size rotary juice screen, 45 tonne capacity mill house EOT crane, Cane preparatory devices, 900 mm diameter single entry condenser, 14' x 28' Vacuum filter, 40' diameter clarifier, 1200 kg/hr capacity lime slacker, Juice defecator, Cane chopper, Cane fibrizer, Cane carrier, Feeder table, Inter rake carrier, Fibrized rake carrier, Rope couplings and distributed control system, Bagasse handling system-Belt conveyor-1600 mm Width, Fibrizer rotor assembly, Belt conveyor supporting structure and its trusses, end carriage for cane unloader, Rake elevator and IRC sprockets, Feeder table shafts and sprockets assembly and bearings, 1500 m² HS Semi-Kestener, 350 m² HS x 3 nos vapour line juice heater.

Shri Datta SSK

2.5 MW BP turbine MRT, ID, FD & SA fans.

Vilas SSK Unit-I

40" x 80" Mill head stock.

Vilas SSK Unit-II

650 kW capacity electrical motor, HT switchboard 11 kV VCB panels, MCC panels.

Loknate Balasaheb Desai SSK

33" x 66" mill with TRPF assembly, 12.5 tonne capacity cane unloader, 1600 mm x 3000 mm size rotary juice screen,

Shri Vighnagar SSK

25 tph incineration boiler ID, FD & SA fans, 7.5 tph capacity coal handling system, 5 tph capacity ash handling system, Boiler feed pumps, 5 tph capacity dump condenser, Coal handling system

Swami Samarth Sugar and Agro

ID fans assembly, Various centrifugal-type pumps, 3.5 mVA distribution transformer, 1.5 mVA converter transformer, 11 kV HT panels, MCC panels GT CRP panels, 1500 kW fibrizer motor

LMGPDnayneshwar SSK

32 tph incineration boiler pressure parts, steam drum, FD & SA fans, 49 m³/h capacity Boiler feed pumps, ESP TR set and TRCC panels, Distillery MCC panels, 3.4 MW Alternator.

Rajarambapu Patil SSKL Unit-I

PCC panels, Boiler and distillery MCC panels, 3 MW Alternator, Control relay panels

Venkateshkrupa Sugar Mills

42" X 84" size x 01 No. head-stock, Top roller, bottom roller and TRF rollers, 750 kW capacity planetary gearbox, 33" X 66" size x 03 Nos. TRF system rollers for existing mill, Distillery MCC panels, 11 kV HT panels, PCC & APFC panels, 5 MW alternator,

Shri Sant Tukaram SSK

16 tph incineration boiler pressure parts, steam drum,

Ambalika Sugar

6.5 MW and 18 MW alternator, HT ICOG panel

Rena SSK

Distillery MCC panel

Karmveer Shankarrao Kale SSK

1500 mm diameter centrifugal 4 Nos. machine

VSI, Pune

500 Kg/batch capacity sigma mixer of for Vasant Urja



Inauguration of 52nd SISSTA Annual Convention at Chennai

ALCOHOL TECHNOLOGY AND BIOFUELS





ALCOHOL TECHNOLOGY & BIOFUELS

The department is engaged in academic, research & development and extension activities in areas of alcohol production, biofuels and distillery effluent treatment. It provides guidance to the alcohol industry for achieving maximum productivity, efficiency and yield from various feedstocks, improving quality of various finished products such as rectified spirit (RS), extra neutral alcohol (ENA), fuel ethanol and achieving Zero Liquid Discharge (ZLD). The department acts as a consultant for ongoing and proposed distillery projects based on Cane syrup, B-heavy molasses (BHM), C-molasses & non-molasses feedstock (Grain, sugar beet, sweet sorghum) and CBG projects. In addition, technical inputs and guidance are given to various government & non-government agencies. The compilation booklet of “Technical performance of VSI member distilleries in Maharashtra” affiliated to sugar mills of the state is published every year.

The laboratory of the department is accredited by National Accreditation Board for Testing and Calibration Laboratories (NABL) for analysis of RS, ENA, Ethanol, Indian Made Foreign Liquors (IMFL), wine and beer. It is also approved by the State Excise Department, Government of Maharashtra for analysis of molasses, grain feedstock, RS, ENA, Ethanol, Country liquor, IMFL, wine, beer and denaturants. The department has wine manufacturing license issued by Food Safety and Standards Authority of India (FSSAI).

M.Sc. (Wine, Brewing and Alcohol Technology) affiliated to the Savitribai Phule Pune University (SPPU), Pune and a post-graduate Diploma in Industrial Fermentation and Alcohol Technology (DIFAT) are conducted by the department. In addition, need based short-term courses in the areas of Alcohol Technology, Biofuels and Effluent Treatment Technologies are conducted. Special training programmes also conducted for officers of the State Excise departments and Central Pollution Control Board (CPCB). VSI was recently accredited by National Assessment and Accreditation Council (NAAC).

The department has also involved in process validation for diversion of various feedstock's like sugarcane syrup and BHM etc. for ethanol production

as per Department of Food and Public Distribution (DFPD), Ministry of Consumer Affairs, GoI, guidelines.

CPCB has awarded the inspection work of 495 industries in Ganga and Yamuna basin to VSI as a third-party inspection agency for Grossly Polluted Industries (GPIs) in 2023-24. VSI is nodal agency for distillery.

RESEARCH AND DEVELOPMENT

Pilot scale studies on recovery of potash from incineration boiler ash

The ash generation can vary depending on type of incineration boiler and supporting fuel used. There are around 100 incineration boilers are installed in distilleries in India and numbers are likely to increase in coming years.

India has imported around 45 Lakh tonne of potash fertilizers during 2021-22. About 40-45% ash generated from incineration boiler is collected in electrostatic precipitator (ESP). ESP ash contains high amount of potash and can be utilized as fertilizer. Remaining quantity of ash produced can be utilized for cement industry and brick manufacturing. Considering the disposal related issue and identifying the potential to recover valuable materials based on composition of incineration boiler ash, the department had undertook a lab scale R & D project entitled “Recovery of potash from incineration boiler ash” funded by O/o. Principal Scientific Adviser (PSA) to the GoI, New Delhi. To validate the lab scale data, VSI further took up a project entitled “Pilot scale studies on recovery of potash from incineration boiler ash”. KS Kale SSK gave funding of ₹ 50 Lakh for the potash recovery pilot plant.

The project objective is to study potash recovery from incinerator boiler ash on pilot scale and validate lab scale result. Total 18 trials on the pilot plant were completed. On the basis of trial data, more than 90% potash is recovered from incinerator boiler ash. Recovered powder has more than 50% K₂O. Field trials of the recovered potash are in progress by Soil Science section of VSI.

On the basis of pilot scale data, 10 ton per day potash recovery plant on commercial scale can generate



around ₹ 400 Lakh income from recovered potash with less than 2-year payback period. As recovered powder has more than 50% K_2O , it can be sold as potash derived from molasses (PDM) which is approved FCO grade (min. 14.5% K_2O). Around 40 incineration boilers are installed in molasses-based distilleries in Maharashtra which can generate more than 1 Lakh ton potash powder per year. This will help to replace almost 20% of total potash requirement (around 5 Lakh ton) of Maharashtra and also reduce import cost.

Biomethanation of cellulosic waste

Government announced mandatory blending of Compressed biogas in CNG (Transport) & PNG (Domestic) segments of City Gas Distribution (CGD) on 25th November 2023. CBG Blending Obligation (CBO) will promote production and consumption of Compressed Bio-Gas (CBG) in the country. It will also encourage investment of around ₹ 37500 crores and facilitate establishment of 750 CBG projects by 2028-29. CBO will be voluntary till FY 2024-2025 and mandatory blending obligation would start from FY 2025-26. CBO shall be kept as 1%, 3% and 4% of total CNG/PNG consumption for FY 2025-26, 2026-27 and 2027-28 respectively. From 2028-29 onwards, CBO will be 5%. Considering initiatives taken by GoI, CBG production seems to be the next golden opportunity for sugar industry to diversify in value added renewable biofuels. This will help to increase the profitability of sugar mills.

In view of above, two pilot scale ($50 m^3$) biodigesters were installed at Nira Bhima SSK by VSI. Using 5% press mud cake (PMC), biogas yield of $100 m^3$ /tonne of PMC was achieved with 65% of methane content. Fermented organic manure trials are in progress.

Green solvent assisted recovery of wax from press mud cake and downstream processing of de-waxed press mud cake through biomethanation and biocomposting

The contribution of natural wax is only 4% of the total wax requirement but the scope of natural wax is expected to increase tremendously. This is due to the diminishing supply of petroleum, a source of paraffin wax together with the transition of public preferences to natural and greener products. Therefore, exploring different sources for natural wax is of vital importance for country like India. Moreover, the wax obtained

from plant waste is desirable to avoid competition for feedstock with other agricultural and food industries. Consequently, wax extracted from the PMC, a byproduct of sugar mills can become a promising candidate of natural wax.

Rajiv Gandhi Science and Technology Commission (RGSTC), Govt. of Maharashtra has provided financial assistance of ₹ 70.37 Lakh for three years for this R & D Project.

The project objective is to recover wax from press mud cake (PMC) and study the biomethanation, biocomposting of raw and dewaxed PMC. Wax recovery of about 10 gm was achieved from 100 gm of wet PMC using batch reactor and screw type extractor. Industry relevant conditions such as grinded and un-grinded PMC, dry and wet PMC, recycle of solvent were tested. It was observed that wax recovery from PMC was not compromised by use of un-grinded PMC, wet PMC and recycled solvent. Purification of crude wax by ion exchange resin was performed and it was comparable with commercial waxes. Anaerobic digestion experiments on 15 L scale were conducted for raw and de-waxed PMC. Biogas generation around 10 L/day ($100 L/Kg$ of PMC) was achieved. Biocomposting experiments were also conducted for raw and de-waxed PMC.

Green hydrogen production opportunities for sugar and distillery industry

GoI announced a “National Hydrogen Mission to make India a Global Hub for Green Hydrogen Production on August 15, 2021. Green hydrogen is produced by electrolysis of water using renewable energy (like Solar, Wind) and has a lower carbon footprint. Electricity splits water into hydrogen and oxygen. Under the Paris Climate Agreement, India pledged to reduce the emission intensity by 33-35% from 2005 to 2030 to reduce import dependency on fossil fuels. India has set target of 80% green hydrogen production by 2050 with respect to its total demand to reduce carbon emission.

Sugar and distillery industries will play a key role in near future as the production hubs of clean biofuels. Hydrogen will be one of the important products being produced in the sugar complex. Sugar industry has excess of power/electricity generated after captive consumption. Excess electricity is sold to grid. Day by

day tariff for electricity is going down. Sugar industry is looking for economically viable alternative like hydrogen production using water electrolysis with electricity. Bagasse (carbon neutral energy source) can be also used for hydrogen production using gasification. In addition, bagasse, press mud cake and spent wash can be used for biogas (60-65% methane) production using anaerobic digestion. Steam methane reforming can be used for production of hydrogen from methane/biogas. Sunlight being one of the most abundant renewable sources of energy can be utilized for the production of green hydrogen using a method called Photo-catalysis. Specially constructed nano-catalysts can be used for this purpose. This project plans to explore the use of various techniques for hydrogen production and their suitability for hydrogen production in sugar & distillery industries.

a. Hydrogen production using water electrolysis on demo scale

The project objective is to study the feasibility of hydrogen production in sugar industry using water electrolysis technology. Demo green hydrogen microgrid system was installed at VSI in January 2024. The installed system capacity is of 2 kg hydrogen per day. Hydrogen production trials are in progress. On the basis of preliminary data, it was observed that 45-50 kW power is required to produce 1 kg of hydrogen.



Green Hydrogen Demo Plant installed at VSI

b. Hydrogen production using nano-catalyst assisted photo electrolysis on lab scale

The project objective is to study the hydrogen production from sugar industry feedstock (spent wash, sugar syrup, etc.) using nano-catalyst assisted photo

electrolysis. Installation of Photocatalytic reactor equipped with mercury and xenon lamp was completed. The protocol for nano-catalyst based hydrogen production using diluted spent wash is completed. Hydrogen production of around 100 ml/g catalyst was observed. The further optimization work is under progress.

Second generation ethanol production through enzymatic route and/or using genetically modified microbial strains

As India is importing 77% of its crude oil requirement, therefore, different agricultural biomass utilization for 2G ethanol production is promoted by GoI. Government has launched the Ethanol Blended Petrol (EBP) Programme to mix ethanol with petrol to reduce the consumption of fossil fuel. In year 2022-23, 12% ethanol blending in petrol is achieved and 20% ethanol blending is aimed up to 2025. Lignocellulosic biomass is considered as a potential resource to produce bioethanol. Rice straw, Bamboo & Sugarcane Bagasse are some of the abundant lignocellulosic waste materials worldwide. The natural structure of lignocellulosic material containing cellulose, hemicellulose, and lignin is extremely recalcitrant to enzymatic hydrolysis. The conversion of biomass to ethanol typically consists of four main steps: pretreatment, enzymatic hydrolysis, fermentation, and distillation. For an economically viable ethanol production at the industrial level, the produced ethanol in fermentation must reach at least 5% (v/v).

A novel 2G ethanol process from bagasse has been developed and optimized on 30 L scale. Achieved targeted ethanol concentration of 7% (v/v) and fermentation efficiency of 80% with yield of 155-160 L per tonne of dry bagasse. Enzyme recovery is necessary as the cost of the imported enzymes is almost 40% of the total cost of the production. The enzyme recovery of 40-50% was achieved on flask scale. Biogas yield of 250 m³/tonne of xylose (35 m³/ton of SCB) obtained using unutilized xylose stream.

In continuation to this work, project entitled “Process development for an economical & sustainable lignocellulosic based ethanol production” was funded by GPS Renewables with funding of ₹ 54.86 Lakh. The project aims to develop a cost-effective process through either biological or chemical pretreatment of



lignocellulosic biomass for ethanol production. Biological pretreatment followed by saccharification & fermentation work is under progress.

Process development for enhanced biobutanol production through fermentation

Butanol is a promising next generation biofuel and biofuel additive, exhibiting several advantages compared to ethanol. Butanol is less hygroscopic, so blending can occur directly in the refinery and the existing infrastructures can be used for transport. Due to a lower vapour pressure, butanol is much safer to handle, and problems to start the engine are prevented during cold weather. The higher energy content of butanol enables to drive more miles with the same amount of fuel.

Butanol can be efficiently produced through acetone-butanol-ethanol (ABE) fermentation by *Clostridium* spp. One of the major bottlenecks of ABE fermentation is butanol toxicity to the producing microbes limits its accumulation in the fermentation broth. Another bottleneck is high cost of the separation of solvents from fermentation broth. So, low yield, low titer, low productivity usually observed. Thus, this problem should be taken into consideration in order to obtain high titre & high-yield butanol via ABE fermentation.

Flask scale screenings of *Clostridium* cultures were performed. Fermentation was performed using synthetic media having CaCO_3 . Maximum butanol concentration of 11 g/L was achieved on lab scale.

Scientific study on mahua spirit ageing and maturation

Mahua tree is known to serve as a part and parcel in the sustainability of the Indian tribal people. Mahua flower has potential as substrate for making good quality liquor. The flavour of the fresh Mahua flower is due to its sweet taste and good odour. In this context, VSI has recently completed one project funded by Government of Madhya Pradesh. Under the technical support of VSI, Heritage Mahua liquor is being produced at Alirajpur District by MP Govt.

Mahua liquor after its production can be stored in barrels for a specified period of time to see the effect of ageing. Ageing is the process of storing distilled spirits in which chemical changes occur during storage. The

objective of ageing or maturation is to eliminate harsh flavours from the raw alcohol while incorporating a distinct taste and aroma derived from properties found in the barrel's wood. The type of wood that is used for aging spirits plays a huge role in determining its overall flavour, aroma, and colour.

The project entitled "Scientific study on mahua spirit ageing and maturation" is funded by the Madhya Pradesh Government with funding of ₹ 13 Lakh. The project objective is to see the effect of ageing & maturation on mahua liquor. Ageing & maturation of Mahua liquor completed for 6 months. From sensory & GC analysis, it was observed that Mahua liquor is suitable for potable purpose as per FSSAI.

Process development for neera based wine, liquor and vinegar production

The sap or Neera is the main product of wild date palm tree (*Phoenix sylvestris*). Fresh palm sap is obtained by the process known as tapping, which is clear, sweet in taste, neutral in pH and contains proteins, lipid, fibers and sugars such as glucose, fructose and sucrose. The sweet sap is either consumed as fresh juice or processed into a broad array of products, including syrup, vinegar, organic acids, sugar, wine and distilled liquor. Neera after fermentation called as toddy. Both neera & toddy usually adulterated by different chemicals in the market. Neera also get spoiled due to improper storage conditions. Therefore, storage study in different conditions is required to avoid wastage & contamination of Neera. Also, there has been much interest in different product formation through which Neera can be processed for the formation of toddy, vinegar & liquors.

Neera storage study was conducted. It was observed that Neera could be stored up to 6 months at different conditions. VSI is also working on the development of adulteration kit for Toddy for which demo kit was prepared for detection of Chloral hydrate. More samples are being collected and tested for the development of Neera & toddy-based adulteration kit. Shake flask scale vinegar production was carried out using *Acetobacter aceti* (NCIM 2251) using Neera. About 40 g/L was achieved using Neera.

Distillery fermentation process modelling and optimization using artificial intelligence (AI)

Distillery fermentation is a complex nonlinear process wherein multiple process variables and parameters interact nonlinearly. Often, the feed (molasses) to the process is of inconsistent quality, which also affects the quality and quantity of the alcohol produced.

In recent years, several AI based novel methods have been proposed for developing process models. These methods are essentially based upon the intelligent behavior observed in Nature. For example, a widely used AI based modeling method known as “Artificial Neural Networks” is based upon functioning of human brain. An important and useful feature of ANNs is that for developing a process model they do not need a detailed understanding of the chemical/biochemical mechanistic phenomena underlying the process. ANNs assume that all such information is contained in the process data. Consequently, models can be developed solely from the historic data of the process inputs (properties of raw material, flow rates, temperature, catalyst concentration, pressure etc.) and outputs (volume and concentration of the manufactured product, yield, etc.).

The objective of the project is to develop AI based fermentation model for estimation of ethanol using input measurement such as temperature, pH and CO₂ on lab scale. In lab scale study, molasses fermentation was carried out on 2 L fermenters equipped with temperature, pH and CO₂ analyzer. Data of 50 Molasses & syrup fermentation batches was collected. On line pH and CO₂ data was used to build model for mapping ethanol (output variable). Preliminary AI based model is developed for ethanol estimation using above measurement. Further model building and validation work is under progress.

Investigations and development of fruit wines from selected North Eastern fruits

Winemaking or production of vinegar from surplus ripe fruits from North-Eastern region or their juices is considered as an alternative route which generates additional revenues for the fruit growers. These trees have the potential to alleviate the poverty, food and nutritional insecurity through processing and value addition. Most of these trees are rich in vitamins,

minerals and such other bioactive molecules suitable for medicine, aromatic and food processing industries. Fruit also is an essential part of our diet that contributes to overall strength for our health. The value added products like fruit wine & vinegar produced commercially will go a long way which will ultimately enhance the cultivated area and thereby enhance the income and nutritional security of the farmers. The project is principally approved by the North-Eastern council. Sanction order of the project is received. The project will be initiated after receiving funds.

CONTRACT RESEARCH PROJECTS

Scientific study on losses of malt spirit during maturation & ageing

Maturation of spirit is slow oxidation process and spirits become soft/smooth after maturation. Depending on the environment, the type of cask, its size, warehouse temperature and humidity, reactions proceed to differing degrees. Clearly, the role of maturation in the development of final spirit flavor is critically important. During maturation process, spirit losses may occur frequently due to various reasons. Due to the porous nature of cask wood, the malt spirit may diffuse out on the surface of the cask. It afterwards evaporates and is lost (called as Angel’s share). The environmental factors such as humidity, temperature etc. may affect on the losses significantly. The losses may vary in different weather conditions and size, shape & type of cask wood used. Based on data to be generated during the proposed studies, standards can be developed for actual losses during malt spirit maturation.

United Spirits Ltd. (USL, a Diageo group company) has approached VSI to conduct scientific study on maturation of malt spirit and losses during its maturation. The aim of work is to conduct scientific study on maturation process of spirit, parameter affecting it and losses during maturation.

The malt spirit maturation losses study was conducted at USL Nashik and VSI, Pune. It was observed that there are losses in spirit samples during storage at USL, Nashik and VSI, Pune.

Storability study of Praj’s PM Stab™ - press mud preservation technology

Indian sugar mills generate additional revenue by



utilizing press mud (a residual byproduct in the sugar industry) as a feedstock for biogas production through anaerobic digestion, leading to the production of CBG. However, press mud potential to produce methane deteriorates with the period of time. The main reason behind the declination is the instability of the organic matter of press mud. In view of these, Praj Matrix has developed a Praj PM Stab™, press mud preservation formulation. Hence, to validate the efficacy of formulation to preserve press mud, VSI carried out the stability study. Formulated press mud sample along

with the regular press mud from two sugar mills were submitted by Praj Matrix to the VSI. It was observed that PM Stab™ treated press mud was stable up to nine months of storage.

EXTENSION AND ADVISORY SERVICES

Detailed project reports (DPRs) and tender documents

DPRs and tender documents for new distilleries, modernization, expansion of existing units and ETPs completed are given in table 1.

Table 1: DPRs and tender documents

Name of distillery	DPRs-Plant capacity and configuration
(Distillery, Spentwash evaporation plant, incineration boiler, turbine and CPU)	
Chhatrapati SSK, Majalgaon	30 KLPD distillery with effluent treatment system
Krushinath Green Energy	60 to 180 KLPD distillery expansion with effluent treatment system
Matoshri Laxmi Sugar and Co-generation Industries	60 KLPD distillery with effluent treatment system
Malhar Sakhar Karkhana	150 KLPD distillery with effluent treatment system
Penganga Sakhar Karkhana	60 KLPD distillery with effluent treatment system
Rajarambapu Patil SSK	150 to 550 KLPD distillery expansion with effluent treatment system
Shree Someshwar SSK	45 to 135 KLPD distillery expansion with effluent treatment system
Sharayu Agro Industries	120 to 360 KLPD distillery expansion with effluent treatment system
S P Sugar & Agro	280 KLPD distillery with effluent treatment system
Yogeshwari Sugar Industries	60 KLPD distillery with effluent treatment system
(Distillery, Biomethanation, Spentwash evaporation plant, spentwash dryer and CPU)	
Ajinkyatara SSK	30 KLPD ethanol & CO ₂ plant with effluent treatment system for 45 KLPD distillery
Athani Sugar, Athani (KA)	90 to 400 KLPD distillery expansion with effluent treatment system
Anuraj Sugar	30 KLPD distillery with effluent treatment system
Kamrej KUSM (GJ)	Installation of new effluent treatment plant for existing 45 KLPD distillery plant
Loknete Balasaheb Desai SSK	60 KLPD distillery with effluent treatment system
PK Dr. NN Hutatma Kisan Ahir SSK	45 to 100 KLPD distillery expansion with effluent treatment system
Sahakari Khand Udyog Mandal Ltd. (GJ)	48 to 100 KLPD distillery expansion with effluent treatment system
Sankalp Green Power	290 KLPD distillery with effluent treatment system
The Malegaon SSK	90 to 240 KLPD distillery expansion with effluent treatment system
Yedeshwari Agro Products, Unit II	250 KLPD distillery with effluent treatment system

Table 1: DPRs and tender documents (Contd...)

Name of distillery	DPRs-Plant capacity and configuration
(Distillery, Thin slop evaporation plant, decantation and mingler)	
DDN SFA, Unit-II	45 to 165 KLPD distillery expansion with effluent treatment system
Yoki Green Energy, Palghar	100 KLPD grain-based distillery with effluent treatment system
(Ethanol plant)	
Rena SSK	30 to 60 KLPD expansion of ethanol plant
(CBG DPR)	
Utopian Sugars	6 TPD Compressed biogas (CBG)
Purna SSK	6 TPD Compressed biogas (CBG)
SM Shankarrao Kolhe SSK	12 TPD Compressed biogas (CBG)
(CO₂ DPR)	
Ashok SSK	40 TPD Liquid CO ₂
Tender Documents	
(Distillery, Spentwash evaporation plant, incineration boiler, turbine and CPU)	
Lok. M Ghule Patil Dnyaneshwar SSK	45 to 100 KLPD distillery expansion with effluent treatment system
Rajarambapu Patil SSK	150 to 550 KLPD distillery expansion with effluent treatment system
Sant Tukaram SSK	45 KLPD distillery with effluent treatment system
(Distillery, Biomethanation, Spent wash evaporation plant, spentwash spray dryer or ATFD and CPU)	
Mohanrao Shinde SSK	60 KLPD distillery with effluent treatment system
PK Dr. NN Hutatma Kisan Ahir SSK	45 to 100 KLPD distillery expansion with effluent treatment system
R P Ghodganga SSK	135 KLPD distillery with effluent treatment system
Rena SSK	60 KLPD ethanol & Spentwash evaporation plant
SM Shivajirao Narayanrao Nagawade SSK	30 to 150 KLPD distillery expansion with effluent treatment system
SMS Kolhe SSK	120 KLPD distillery with effluent treatment system
Vishwasrao Naik SSK	60 KLPD distillery with effluent treatment system
(CBG)	
SM Shankarrao Kolhe SSK	12 TPD Compressed biogas (CBG)

Adequacy assessment reports (AARs) for distillery ETPs in Ganga Basin and other states

VSI team carried out inspection of fermentation, distillation and ETP sections of 175 KLPD distillery of Dwarikesh Sugar Industries, Dwarikesh Dham, Bareilly, (UP) and 45 KLPD distillery plant of SM Bhausahab Thorat SSK (Maharashtra). During inspection, the team discussed with concerned officers on various issues related to distillery, performance of ETP's, operational problems and collected necessary information. The AARs of distillery ETP's were prepared and submitted to concerned distilleries.

Technical offers and state level machinery purchase committee (SLMPC) meetings for distilleries and ETPs

Technical offers received from different suppliers were critically evaluated, comparative statements were prepared and submitted to the concerned distilleries and/or SLMPC. The department attended pre-bid, technical sub-committee and SLMPC meetings at MRSSK Sangh, Pune for S.M. Shankarrao Kolhe SSK, Mohanrao Shinde SSK, Rena SSK, Vishwasrao Naik SSK, Rajarambapu Patil SSK, Sant Tukaram SSK, Lok. Marutrao Ghule Patil SSK.



Recommendation for proposals

The department has provided technical recommendations required for setting-up of new distilleries, new ETPs and modernization/modification of distilleries and ETPs are mentioned in table 2.

Inspection of plant & machinery, consultancy services

During project execution, layout, GA, structure drawings, PFDs, P & IDs were checked and approved.

The details of consultancy services were provided to 22 distilleries including distillery plants, biomethanation, spentwash evaporation system, spentwash dryer and CPU as mentioned in the table 3.

Certification of distillery layout for tri-party agreement with OMCs for ethanol production

The department has certified the distillery layout for tri party agreement with OMCs for ethanol production (Table 4).

Table 2: Recommendations for new distilleries, ETPs, expansion and modernization

Name of distillery	Details of proposals
Dr. B Ambedkar SSK	Installation of new equipments for sugarcane juice transfer to the distillery plant and spentwash recycle to the fermentation section
Rena SSK	Expansion of ethanol plant from 30 to 60 KLPD
Saipriya Sugars & Distilleries (KA)	Installation of new fermenter for fermentation of sugarcane juice/ B-Hy molasses & to increase the feed temperature of fermented wash to distillation column, 1No. of PHE to be installed.

Table 3: Inspection of plant & machinery and consultancy services

Name of distillery	Details
(Distillery, Spentwash evaporation, incineration and CPU)	
Ashok SSK	60 KLPD distillery with effluent treatment system
Dr. P Kadam Sonhira SSK	110 KLPD distillery with effluent treatment system
Jaywant Sugars Ltd.	60 to 105 KLPD distillery expansion with effluent treatment system
KAT Samarath SSK Unit-I	100 KLPD distillery with effluent treatment system
Lok. Marutrao Ghule Patil Dnyaneshwar SSK	45 to 100 KLPD distillery expansion with effluent treatment system
Rajarambapu Patil SSK	55 KLPD distillery with effluent treatment system
Shree Datta Shetkari SSK	97 KLPD distillery with effluent treatment system
Shri Sharad SSK	30 KLPD distillery with effluent treatment system
Shri Sant Tukaram SSK	30 KLPD distillery with effluent treatment system
Vighnagar SSK	65 KLPD distillery with effluent treatment system
(Distillery, Biomethanation, Spentwash evaporation plant, spentwash dryer and CPU)	
Dwarkadhish Sakhar Karkhana	45 KLPD distillery with effluent treatment system
KAT Samarath SSK Unit-II	60 KLPD distillery with effluent treatment system
Rena SSK	45 KLPD distillery with effluent treatment system
Venkateshkrupa Sugar Mills	250 KLPD distillery with effluent treatment system
Vilas SSK Unit-II	90 KLPD distillery with effluent treatment system
(Distillery, Biomethanation, Spentwash evaporation plant, Biocomposting and CPU)	
Ajinkyatara SSK	20 KLPD distillery plant with effluent treatment system
Kadwa SSK	30 KLPD distillery plant with effluent treatment system
Other	
Dr. B Ambedkar SSK	Pre-fermenter, Fermenter, 60 KLPD MSDH & CPU
Kumbhi-Kasari SSK	30 KLPD MSDH plant with PESO storage, 260 m ³ /day Spent wash evaporation plant and 600 m ³ /day Condensate polishing unit
SM Shankarrao Kolhe SSK	180 TPD spray dryer, Molasses tank-2 Nos. (10,000 MT each)

Table 4: Certification of ethanol plant as per EOI

Name of distillery	Capacity of distillery plant (KLPD)
Cuttack Agrivet, Dumpada (Odisha)	200 KLPD (Grain based distillery)
KRIBHCO Green Energy, Industrial Area Survepalli, Venkatachalam Mandal, SPSR Nellore, Andhra Pradesh	270 KLPD (Grain based distillery)

Process validation reports on “Mechanism for diversion of sugarcane juice or sugar syrup or sugar or BH molasses to produce ethanol” for the distillery attached to the sugar mill

The Government has been exploring alternate routes for encouraging production of ethanol to bridge the demand and supply gap for the Ethanol Blending Programme (EBP). As per notification from Department of Food and Public Distribution (DFPD), sugar mills are allowed to produce ethanol directly from sugarcane juice or sugar syrup or sugar or BH molasses.

Alcohol Technology & Biofuels and Sugar Technology departments jointly visited sugar mills & distilleries in Maharashtra and other states for verification and compliance of the DFPD guidelines and collected of data for preparation of validation reports. Process validation reports were prepared for 87 distilleries attached to sugar mills from Maharashtra, Chhattisgarh, Karnataka and Punjab for diversion of sugarcane juice or sugar syrup or sugar or BHM. These process validation reports will be helpful for the State Excise Department or any other agency designated by State Government to certify ethanol production routes.

Visits

The staff visited 325 member and non-member distilleries in the state & other states, Government offices and Institutions for different assignments. The details of visits with assignments are given in Annexure - IX.

Yeast culture bank

VSI provided a total 28 slants of yeast culture (VSI 1011) to member and non-member distilleries across the country. Based on the feedback received from the distilleries, it was found that the performance of yeast cultures provided by VSI was quite good.

Analytical services

Various samples analyzed by wet chemical methods, GC, GC-MS, HPLC, IC, Anton Paar and material

testing by PMI machine are mentioned in table 5. A total 39,342 samples were analyzed in the department.

NABL

NABL accreditation for AT & B laboratory is renewed. During year, total 49 samples were analyzed under NABL (Beer & wine sample-37 Nos., IMFL-6 Nos. and RS, ENA, Ethanol- 6 Nos.).

Calibration work

Calibration was done for 463 Sykes hydrometers, 20 specific gravity hydrometers, 27 brix hydrometers, 17 alcohol meters and 241 thermometers (total 768).

Analysis and processing of Sweet sorghum stalk for fermentability and ethanol production

Seven different varieties of Sweet sorghum samples were received from M/s. Paani Foundation, Mumbai and two varieties from M/s. Advanta Enterprises Hyderabad for analysis and to find out its suitability for alcohol production. All above varieties of Sweet sorghum were analyzed, tested for alcohol production and found suitable.

Sweet sorghum syrup of three different varieties were received from M/s. Sahyadri Farms Post Harvest Care, Mohadi, Nashik, for analysis and to find out its suitability for alcohol production. Syrup samples found suitable for alcohol production.

Improving performance of distillery units

Services rendered to distilleries in improving performance and addressing process problems are stated in brief as under:

KSB Patil SSK

The distillery unit approached VSI for the pale yellow colour for impure spirit. VSI team visited distillery unit and checked the soft water feed to fusel oil decanters and found that fusel oil is not separated properly due to this impure spirit having colour. It was suggested to remove soft scale in piping. After removal of scale from piping, required quantity of soft water feed given to the decanters, fusel oil is separated from decanter and pale yellow colour was vanished after 7-8 hrs. It has helped to improve quality of rectified spirit.



Table 5: Samples analyzed by various analytical methods

Name of sample	No. of samples analyzed by		
	Chemical / Wet analysis	GC, GC-MS, HPLC, IC and PMI	Anton Paar
Samples from State Excise Dept., Maharashtra			
Beer	---	---	5212
Country liquor	--	---	8610
IMFL	--	45	15155
Molasses	2569	--	--
Spentwash	01	08	16
Wine	--	--	460
Other			
Caramel	12	--	--
Extra Neutral Alcohol	45	62	26
Ethanol	54	47	--
Excise Grain samples	259	--	--
Excise Denaturant and Bitterant	5692	--	--
Fermentability of molasses	3	--	--
Food flavor	11	--	--
Honey	--	7	--
IMFL+CL	7	26	13
Material testing with PMI machine	--	710	--
Molasses from distilleries and sugar mills	40	10	--
Molasses – Microbial analysis	8	--	--
Rectified spirit	58	66	62
SDS/ODS	--	48	--
Total	8759	1029	29554

KAT Samarth SSK, Unit I

The distillery unit approached VSI to rectify problem related to alcohol yield of molasses. VSI team visited distillery unit and carried out analysis of molasses, fermented wash and spentwash samples.

It was observed that lower alcohol yield was due to losses of sugar in fermentation and alcohol losses in distillation. The above problem was rectified by avoiding contamination and maintaining proper yeast cell count in propagation and fermenter. To avoid alcohol loss through spentwash, analyzer column bottom temperature was maintained at 80-82°C.

Saipriya Sugars & Distilleries Pvt. Ltd. (Karnataka State)

The distillery unit approached VSI for lower production capacity. VSI team visited distillery unit. It was observed that there was sugar loss in fermentation

due to lower retention time in fermentation. It was suggested to install one new additional fermenter in existing fermentation house.

Nirani Sugars, Mudhol Pvt. Ltd. (Karnataka State)

The distillery unit approached VSI for problem of low alcohol percentage in fermented wash. During visit, VSI team observed that the average volatile acidity of syrup was 3,000 to 5,800 mg/L. It was suggested to use antibiotics to avoid contamination, maintain hygienic condition around mill and fermentation area. After implementation of suggestions, the volatile acidity of syrup was reduced down to 1000-1500 mg/L accordingly alcohol % in fermented wash was increased to around 12.0% (v/v).

Malegaon SSK

The distillery unit approached VSI for problem of biogas plant stabilization. VSI team visited the biogas

unit. It was observed that higher alkalinity in the digester. To improve the performance of digester, it was suggested to add cow dung, urea & DAP to both the digesters and adjust digester feed as per requirement. After one month, both digesters were stabilized with biogas production of 800 M³/hr.

Technical guidance to Government and Non-Government organizations

The member distilleries require administrative and financial clearances from the statutory bodies for replacement of their old machinery and to set-up new projects. Therefore, the department has provided guidance to Commissioner of Sugar and SLMPC. In addition, the guidance was provided to DFPD, MoEF, All India Distillers Association (AIDA), Ethanol Association of India, Distillers' Association of Maharashtra (DAM), CPCB, Maharashtra Pollution Control Board (MPCB), Indian Sugar Mills Association (ISMA), Maharashtra and Karnataka State Excise Department.

The department has conducted three special training programmes for State Excise Assistant Commissioner and Deputy Superintendent, GoM. The department has also conducted short term training programme for officers from CPCB.

Technical performance of VSI member distilleries and effluent treatment plants affiliated to sugar mills in Maharashtra

The department published a booklet entitled "Technical Performance of VSI Member Distilleries in Maharashtra for the financial Year 2021-22 and 2022-23". Ninety two distilleries were functional in 2022-23. The data on technical performance of distilleries for the previous five years is presented in following table 6.

Academic

The department is involved in conducting DIFAT course and MSc (Wine, Brewing and Alcohol Technology) course affiliated to the SPPU, Pune. As suggested by SPPU, Pune the syllabus of first year of M.Sc. (WBAT) was revised and submitted. The students of M.Sc. (WBAT) and DIFAT were placed in the companies such as Praj Industries, Allied Blenders & Distillers Ltd., United Brewery Ltd., D J Distillery Ltd., Fratelli Wines Ltd., Goa Brewing Company Ltd., Geist Microbrewery, Rodney Strong Wines (USA), Marry hill Winery (USA), Shree Renuka Sugars Ltd., India glycol Radico Khaitan Ltd., Tilaknagar Industries Ltd., Catalyst Biotech and EID Parry India Ltd.

Table 6: Technical performance of VSI member distilleries in Maharashtra

Technical Parameter	Year				
	2018-19	2019-20	2020-21	2021-22	2022-23
Production capacity (Million Lits./300 days) considering all distilleries.	1086.0	1099.5	1153.5	1322.70	1569.0
Production capacity (Million Lits./300 days) Based on received information	850.00	682.80	889.46	1082.70	1329.0
Number of distilleries whose information was compiled	57	50	58	63	62
Average net working days	197.00	151.00	140.00	140	--
C- Molasses consumed (Million tonnes)	2.142	1.344	1.020	0.709	0.606
BHM consumed (Million tonnes)	0.166	0.265	0.682	1.488	2.061
Sugarcane juice consumed (Million tonnes)	0.057	0.182	1.007	1.640	2.473
Alcohol produced (Million litres)	635.53	457.82	574.95	783.21	1068.27
Average Fermentation Efficiency (%)	89.89	89.76	89.75	89.99	90.12
Average Distillation Efficiency (%)	98.52	98.48	98.46	98.52	98.22
Recovery of Alcohol (Litres/MT of C-molasses)	271.46	266.55	274.82	280.04	290.71
Recovery of Alcohol (Litres/MT of BH-molasses)	301.37	321.66	316.84	306.23	315.71
Recovery of Alcohol (Litres/MT of Sugarcane)	82.05	78.93	77.93	77.59	76.06
Capacity utilization (%)	77.31	67.05	64.64	74.82	88.74

ENVIRONMENTAL SCIENCES



ENVIRONMENTAL SCIENCES

World over, industries face the challenges of keeping up production amidst concerns of health, safety and environment. The sugar and allied distillery industry too are not isolated from this situation. This department assists the sugar and allied industry in addressing environmental concerns through research, consultancy and teaching/training. There is an increased focus on environmental issues in this sector due to stringent implementation of environmental regulations, environmental awareness among various stakeholders and also some incidences of accidents causing environmental damage. The industry is included in the list of grossly polluting industries and the Central Pollution Control Board (CPCB) is also inspecting industries for violations and non-compliances. The department participates in the annual inspection of GPI's in the Ganga/Yamuna basin and has given inputs to CPCB for preparation of comprehensive charters for effluent treatment as well as for preparation of model consents for this sector.

The research focuses on finding sustainable solutions to environmental problems including waste reduction, treatment and disposal. The consultancy services include environmental impact assessment, environmental audits, and preparation of project reports for establishment and up-gradation of effluent treatment plants, adequacy reports for effluent treatment plants and air pollution control devices, environmental clearance compliance reports, environmental monitoring and analysis. The services also include environmental damage assessment studies as well as guidance for greenbelt development and implementation of CER budget. The department is accredited by National Accreditation Board for Education & Training (NABET) for carrying out EIA studies and recognized by the Maharashtra Pollution Control Board (MPCB) for carrying out Environmental Audits. The environmental laboratory is accredited by NABL as per ISO 17025:2017. Human resource development in the area of environment is addressed through conducting MSc and PhD programs in Environmental Sciences, short term training programs for industry personnel and sponsored programs from CPCB. The department also organizes workshops on current environmental issues and latest regulations to

keep the industry updated on these issues. It also communicates with MoEFCC, CPCB & MPCB regarding issues of environmental importance concerning the sugar and allied distillery industry.

RESEARCH

Assessment of workplace air quality in various sections of a sugar mill/allied units

The second cycle of visits to sugar mills was completed for work on mitigation strategies to reduce particulate matter in indoor air. Work was done on mitigation strategies to reduce particulate matter in indoor air of sugar mills. This is being done with Sugar Engineering Department of the Institute.

Dust collector on sugar hopper, covered hopper system, net shed etc. are mitigation strategies used for reducing particulate matter. Second cycle of monitoring at M/s. Venkateshkrupa Sugar Mills, M/s. Sharayu agro Industries and M/s. Kumbhi-Kasari SSK was completed for comparison in pollution load (particulate matter) as these mills have installed/used measures to reduce air pollutants. Closed sugar packaging room, separate cabinet, as well as a dust collection/capture assembly were identified as the best techniques used for controlling sugar dust.

As per data calculation by Completely Randomized Design analysis, calculated value of F at milling section is 26.4198 and table value of F is 3.52 estimated. At sugar packaging house, 60.8435 is a calculated value F and 3.01 is a table value of F. It shows that calculated value of F is greater than table value of F. It means there is significant difference between the treatment means and there is significant difference between PM 2.5 values with and without control measures taken industry at mill section and sugar packaging house. Statistical analysis of 3 season monitoring and comparative study data is in process. Data compilation, interpretation of result and final report writing are in progress.

Analysis and evaluation of questionnaires collected regarding of health status of personnel working in sugar industry was carried out. Total 78 people from 03 sugar mills were interviewed for health effects. Shortness of breath and wheezing/whistling were the major health



problem identified from the questionnaire. More than 17% people were facing problem of shortness of breath and 14% were affected by wheezing/whistling.

Monitoring the water footprint of the sugar industry

Referencing was done on the water footprint of the sugar industry including the water requirements and wastewater generation within the sugar and allied sectors. This is done by Assessment Manual, research papers, and water footprints of various agro-based industries. Site visits were conducted at Shrinath Mhaskoba SKL, Shri Sant Tukaram SSK, and Malegaon SSK to collect information on freshwater requirements in terms of quality and quantity, as well as details on freshwater needs, condensate generation, and its reutilization. An assessment of the water balance in the sugar industry is prepared, examining detailed water inputs and outputs based on units and operations within the industry. Meetings and discussions were held with officers from three sugar mills *viz.* Shreenath Mhaskoba SK, Malegaon SSK, Shri Sant Tukaram SSK and Shri Datta SSK to assess their water footprints.

Sample of water, effluent and condensate collected from above mentioned sugar mills and analyzed in the Department's laboratory for various parameters. It was observed from the analysis that COD values of vapor condensate of evaporation body no 2 is less than their subsequent other evaporation bodies therefore it may be possible to reuse the condensate directly without any treatment and it will help to reduce the grey water footprint and requirement of fresh water i.e. requirement of blue water footprint. Shri Datta SSK used the treated condensate in the process of sugar production and reduced their grey water footprint and blue water footprint. During analysis of treated effluent, it is observed that if treated effluent used for gardening and nearby farms it will reduce the blue water footprint. A brief questionnaire has been prepared to collect data from sugar mills, facilitating the mapping of their water footprints.

Study on characterization of flue gasses due to burning of spent wash and coal/bagasse focusing on measuring the levels of dioxins/furans, CO, VOC and NMHC

Results of analysis of concentrated spent wash are presented here.

- Brix of concentrated spent wash was observed in the range of 48.1 to 51 degree.
- Chloride content in the sample vary from approx. 22,000 mg/L to 42,000 mg/L i.e. 22 to 42 kg/m³
- COD values was observed in the range of 372,000 mg/L to 420,000 mg/L.
- BOD values observed in the range of 149,000 to 151,000 mg/L.

During the reporting period, the Department approached a laboratory (Bioanalytical Technologies India, Pune) for dioxin sample analysis. During the meeting and subsequent discussions as well as literature survey, it was observed that the dioxin sample collection and its analysis protocol development is feasible. This process involves a joint effort between this department and Bioanalytical Technologies India, Pune. Method for sampling of dioxin is available with US Environment Protection Agency's portal. This method needs to be checked for its technical feasibility (i.e. technical setup development at our lab) for our environment and industrial conditions. This is a main part in the protocol development. Therefore, protocol development work will be on trial-error basis. Meetings are in progress for planning the experiments of the research.

Treatment of sugar industry and distillery effluent using microbial fuel cell with bio-electrode

Microbial Fuel Cells (MFCs) are bioreactors that convert the energy in the chemical bonds of organic compounds into electrical energy through catalytic activity of microorganisms. High energy consumption is a disadvantage of aerobic wastewater treatment. MFC's can serve the dual purpose of wastewater treatment along with energy generation. This project of treatment of sugar industry and distillery effluent using MFC with bioelectrodes has been taken up in collaboration with College of Engineering Pune Technological University (COEPTU).

Dual chamber microbial fuel cell of working volume 500 ml made of glass was designed to treat sugar industry effluent. The two compartments are separated using Nefion N117 (proton exchange) membrane. Electronics circuits are designed to measure the voltage difference.

Initial experiments were carried out with sugar effluent using the dual chamber microbial fuel cell and rice husk electrode. Initial voltage of 0.2 V and max. voltage of 0.4 V was observed when sugar effluent is used as anolyte and distilled water is used as catholyte. Further experiments are in progress.

Use of Rotary Vacuum Filter (RVF) as an alternative for clarification system in effluent treatment plant

The referencing and technical data collection tasks have been completed for the lab-scale model making of RVF. During this season, visits were made to sugar mills, for discussion with RVF operators and engineers to gain information of the working process and engineering of RVF. Detailed notes and photographs were taken of equipment, including vacuum pumps, gearboxes, mesh size, piping, and scrapper mechanisms. Samples were collected from the inlet and outlet of RVF and analyzed in the VSI laboratory. The analysis focused primarily on the MLSS of RVF inlet and MLSS present in a typical aeration tank of sugar ETP.

During analysis it was noted that the MLSS in the aeration tank sample ranged from 3-4%, while the feed of RVF was found to be 5-7%. (Without addition of bagacillo). Based on the MLSS in the aeration tank sample, the optimization of the mesh screen size or porosity of the RVF model is currently underway. Various experiments carried out on vacuum cleaner using filter cloths of different sizes for optimization of mesh screen porosity. Lab scale experimental setup is installed in VSI lab to develop MLSS for experimentation.

Workshops were visited, and discussions were held with fabricators for lab-scale model construction. An AutoCAD design of the lab-scale model has been prepared and shared with the aforementioned workshops, and discussions regarding their potential for model construction have taken place. The estimation of the basic cost, materials, and accessory equipment for the RVF model is currently in progress. Discussions were held with four sugar mill officers regarding the project setup at their ETP. Four sugar mills have been identified for the setup of the experimental model at their ETP, namely Malegon SSK, Someshwar SSK, KDGDB Lad SSK, and Shreenath Mhaskoba SK.

EXTENSION AND ADVISORY SERVICES

Environmental Impact Assessment (EIA)

Establishment and expansion of most industrial/infrastructure projects require prior Environmental Clearance from the Ministry of Environmental Forests & Climate Change (MoEFCC). EIA is a crucial part of this process and its objective is the integration environmental concerns while planning for any developmental activity. Adhering to this objective, the department provides EIA consultancy services to the industry. It helps the industry to understand the environmental issues at planning stage itself and thus enables them to address those issues properly.

MoEFCC accepts EIA reports only from consultants accredited by National Accreditation Board for Education and Training (NABET) of Quality Council of India (QCI). The Institute is accredited for three sectors *viz.* sugar, distillery & thermal power (cogeneration) since 2011. The assessment of VSI for the fifth accreditation cycle was done by NABET in March 2024 and results of the assessment are awaited.

In addition, the department also guides the industry for compliances related to environmental clearance. It includes environmental monitoring work as per the EC conditions. A summary of the work in this regard is given in table 1.

Compliance of environmental clearance

Environmental Clearance (EC) is issued to industries with general and specific conditions, which have to be complied mandatorily. Six-monthly compliance reports are to be submitted by the industry to concerned regional offices of MoEFCC. In case, expansion of a project is planned, then certification of EC compliance report by RO, MoEFCC is essential after site visit. The department also offers its services for preparation of such compliance reports for sugar and distillery industry. Guidance is also given to the industry for preparation of such reports. The status of work in this regard is given in table 2.

Environmental damage assessment study

Environmental damage assessment study undertaken for M/s. SMS Nagawade SSK located in Shrigonda taluka of Ahmednagar district. There was an



Table 1: Summary of EIA consultancy work (2023-24)

Industry	Project	Highlights of work	Status /Remark
Kumbhi-Kasari SSK	Environmental clearance (EC) for Expansion of Sugar, cogeneration and molasses-based distillery	Terms of reference (ToR) granted by the Ministry of Environment, Forest and Climate Change (MoEFCC), baseline data collection completed and EIA report preparation work in progress	EIA report preparation work in process
Chhatrapati SSK, Majalgaon	New 45 KLPD molasses- based distillery project	The project was presented to State EIA Authority (SEIAA) for the grant of EC	SEIAA Maharashtra granted EC
Shree Someshwar SSK	Expansion of sugar unit from 5500 to 8000 TCD, cogeneration from 18 to 36 MW & molasses-based distillery unit from 30 to 90 KLPD	Additional details sought by the State Expert Appraisal Committee (SEAC). Prepared compliance and submitted to SEAC	SEAC meeting for consideration of proposal is awaited (SEAC not in place due to completion of its tenure; awaiting for new SEAC)
Rajarambapu Patil SSK	Expansion of molasses-based distillery unit from 150 to 550 KLPD	Environment Management Plan (EMP) prepared and presented the proposal at Expert Appraisal Committee (EAC) of MoEFCC	EAC granted the EC to the project
Krantiagrani Dr. GD Bapu Lad SSK	Expansion of Sugar unit from 8,500 to 11,500 TCD	Application with Form-1, PFR prepared submitted for ToR	ToR granted by MoEFCC
Vilas SSK, Unit-II	Amendment in existing EC of distillery unit	The project was presented to SEAC & SEIA	EC amended
Kunturkar Sugar & Agro	New 30 KLPD molasses-based distillery	The project was presented to SEAC & SEIAA	EC granted by SEIAA
Dwarkadhish SK	Expansion of distillery unit from 30 to 95 KLPD	The project was presented to SEAC & SEIAA	EC granted by SEIAA under B2 category
Karmaveer Shankarrao Kale SSK	Expansion of sugar unit from 4,000 to 7,500 TCD and distillery unit from 45 to 120 KLPD	EIA report prepared and submitted to the MPCB to conduct public hearing	Public hearing Awaited
VVD Manjara SSSK	Expansion of sugar unit from 4,750 to 7,500 TCD	Baseline monitoring is in progress	Preparation of ToR application is in process
Yoki Green Energy 1	New 120 KLPD grain based distillery	Proposal submitted under B2 category. Prepared and submitted EMP to MoEFCC	Awaited for EAC meeting for EC
The Malegaon SSK	Expansion of distillery unit from 60 to 240 KLPD	Baseline monitoring is in progress	Preparation of ToR application is in process

Table 2: Environmental Compliance Reports: Summary of work

Industry	EC compliance for	Highlights of work and status
Khandoba Distillery	Molasses based distillery of 150 KLPD and 6 MW cogeneration unit	Monitoring allied to EC compliance completed for the period of January to June 2023 report submitted to MoEFCC regional office, Nagpur. Six monthly report for July to Dec. 2023, completed.
VVD Manjara SSSK	Expansion of molasses based distillery unit from 60 to 150 KLPD	Monitoring allied to EC compliance completed. Report preparation is in process
Lok. Sunderraoji Solanke SSK	Expansion of existing distillery unit from 90 to 150 KLPD, sugar mill from 5,000 to 6,000 TCD	Monitoring allied to EC compliance for the period January to June 2023 completed. Report for the period of July to Dec. 2023 is in process
Kumbhi Kasari SSK	Expansion of sugar unit from 3,000 to 5,000 TCD and cogeneration from 2 to 19.5 MW	Report submitted for the period of January to June 2023 to MoEFCC regional office, Nagpur. Certification of the compliance is requested.
Udagiri Sugar & Power	Environmental clearance for expansion of distillery unit from 55 to 175 KLPD	Monitoring allied to EC compliance for the period of Nov. 2023 to April 2024 completed. Report preparation is in progress.
Dr. Patangrao Kadam Sonhira SSK	Expansion of sugar unit from 7,000 to 10,000 TCD and expansion of distillery unit from 60 to 135 KLPD	Monitoring allied to EC compliance for the period of July to Dec. 2023 completed. Report preparation is in progress.

accident in the industry in February 2022 when bursting of a molasses storage tank resulted in spreading the molasses in the outside environment and caused damage to soil, crop and waterbodies. MPCB instructed the distillery management to undertake damage assessment study and prepare a detailed report from a reputed institute. The work was allocated to this department. To assess the damage, a team of experts from the department visited the site and am undertook detailed monitoring and geological investigations of the site, particularly, the affected area. Report was prepared and submitted.

The department has also received an assignment for environmental damage assessment from LMGP Dnyaneshwar SSK, Newasa for the assessing the damage caused by spentwash lagoons/compost site to the groundwater and soil.

Sugar ETP consultancy

The sugar ETP consultancy consists of preparation of DPRs/detailed specifications/ tender documents for new ETP/ condensate polishing unit (CPU)/ spray pond over flow treatment. Sewage treatment plant (STP); up-gradation of existing ETP/CPU, trouble shooting for

operation and maintenance of these units, ETP adequacy, ETP performance assessment. The details of the ETP consultancy for sugar mills is given in table 3.

ETP adequacy, validation and performance assessment

CPCB has been regularly visiting mills and in case of doubtful operation of ETP, mills are asked to get the ETP adequacy report from third party institutes like VSI. ETP adequacy is also suggested as a part of the CPCB GPI inspection reports. In addition to this, MPCB also incorporates the condition of getting ETP adequacy reports in its CtO (Consent to Operate). ETP adequacy was carried out at the following mills.

1. Narmada Khand Udyog Sahakari Mandali, Gujarat
2. The Karnal Cooperative Sugar Mill, Haryana
3. Panipat Cooperative Sugar Mill, Haryana
4. Shree Renuka Sugar, Hawalga Unit, Karnataka
5. SBEC sugar Mill, UP
6. Sant Kurmadas SSK, Solapur
7. Athani Sugars Ltd, Bambawade Unit
8. Bajpur Cooperative Sugar Mill, Uttarakhand



Table 3: Details of ETP consultancy

Type of Consultancy	Client Name	Work completed during 2023-24
New Sugar ETP	Shivneri Sugar, Satara	Inspection visits during the Execution work, civil construction and erection work
	Samarth SSK, Unit-I	Inspection visits during the Execution work, civil construction and erection work. Commissioning is in progress of the said plant
	Jaihind Sugar, Solapur	Work order received for a new ETP of 1500 KLPD capacity
ETP Upgradation for Sugar Unit	Chhatrapati SSK, Majalgaon.	DPR prepared submitted. Inspection work during the erection and commissioning of the ETP upgradation work
	Nandi SSKNiyamit, (KA)	Visit for inspection of erection work
	Modi Sugar Mills (UP)	Detailed proposal for ETP upgradation has been submitted to the client
	Sonipat Cooperative Sugar Mill, Haryana	Detailed proposal for ETP upgradation work has been submitted to the mill
	Karnal Co-operative Sugar Mill, Haryana	DPR prepared for ETP upgradation and submitted to the client
	Narmada Khand Sahakari Udyog Mandali Gujrat	Detailed specification and layout submitted for perusal
	V VD.Manjara SSSK, Latur	Detailed project report submitted to the client
	Narayangarh Sugar Mills, Haryana	Work order received for ETP upgradation
Condensate Polishing Unit (CPU)	Someshwar SSK	Work under execution
	Pd. Dr. DY Patil SSK Gaganbawada, Kolhapur	Detailed project report prepared and submitted to the client for CPU/Spray pond overflow treatment plant
	Karnal Co-operative Sugar Mill, Haryana	DPR prepared and submitted to the client
	Loknete Sunderraoji Solanke SSK	DPR prepared and submitted to the client
	Krantiagrani Dr. GD Bapu Lad SSK	Technical visit for inspection of construction, erection and commissioning of CPU
	Shivneri Sugar Mill, Satara	Detailed specification submitted to the mill, execution of work is in progress
Spray Pond Overflow (Wastewater) treatment Plant	Krantiagrani Dr. GD Bapu Lad SSK	Visit for inspection of construction, erection and commissioning of Spray pond overflow (wastewater) treatment plant
	Pd. Dr. DY Patil SSK	DPR prepared and submitted to the client
Sewage treatment Plant	The Malegaon SSK	DPR submitted to the client, execution work is in progress
	Shree Someshwar SSK	Detailed project report prepared and submitted to the client, tendering is in progress

Technical visit for ETP and wastewater minimization

The department has developed considerable expertise in wastewater minimization and ETP troubleshooting. Industry approaches the department for guidance to identify and solve ETP/CPU operational problems. The following sugar mills were visited for providing services in this regard

1. Vilas SSK Unit-II
2. Uttam Surco Tech. UP
3. KAT Samarth SSK Unit-I
4. KAT Samarth SSK Unit-II
5. Indreshwar Sugar
6. Ashti Sugar
7. Rajaram Bapu Patil SSK
8. Shreenath Mhaskoba Sakhar Karkhana
9. Kallappaanna Awade Jawahar SSK
10. Modi Sugar, UP
11. Nira Bhima SSK
12. Dwarkadhish Sugar Mill
13. Shri Sant Tukaram SSK

Air pollution control equipment adequacy

Sugar mills use bagasse fired boilers which generate particulate pollutants. If air pollution control devices installed in such mills are not adequate, it can result in severe impact on air quality. Along with ETP adequacy, CPCB or MPCB now also asking certain mills for third party adequacy report of their air pollution control equipment. The department studied and prepared adequacy report of air pollution control equipment for

- SBEC sugar Mill, UP
- Narmada Khand Udyog Sahakari Mandali, Gujarat

Environmental Monitoring and Analysis

Regular environmental monitoring and analysis is essential for efficient environmental management. Monitoring of environmental baseline is an important part of EIA studies and it is essential that the laboratory engaged for this work is accredited by NABL or recognized by MoEFCC. The laboratory of the department is accredited by the NABL. The scope of accreditation covers >75 parameters of water, wastewater, air, noise, soil, compost and solid/hazardous waste. All NABL accredited laboratories of the institute are now amalgamated and following the new standard ISO 17025:2017.

Environmental monitoring was carried out at units listed in table 4.

In addition, the laboratory analyzed samples from sugar mills, farmers, housing complexes and other industries. The details of samples analyzed are given in table 5.

Table 4: Details of environmental monitoring

Name of Mill	No. of Monitoring
Malegaon SSK	6
Shri Sant Tukaram SSK	3
Khandoba Distilleries	2
Loknete Sunderraoji Solanke SSK	2
Vikasratna VD Manjara SSSK	1
Udagiri Sugar & Power	1
Dr. Patangrao Kadam Sonhira SSK	1

Table 5: Details of samples analyzed

Type of sample	Number			
	Regular Sample	EIA Sample	Damage Assessment	Research samples
Air	103	240		2
Noise	97	29		
Water	141	23	1	
Waste-Water	219			37
Solid waste and compost	85			
Soil	19	12	1	
Sub total	664	304	2	39
Total Samples analyzed	1009			



Inspection of GPIs in the Ganga & Yamuna Basin

VSI was given an assignment of inspection of grossly polluting industries (GPIs) in the Ganga and Yamuna basin by CPCB. This inspection is carried out by third-party institutes (TPIs) like VSI, Pune; NSI, Kanpur; IIT, Delhi and Roorkee and NEERI, Nagpur. A team from VSI inspected several industries as a part of this work. The staff of the department was involved in the inspection of 90 industries including sugar, distilleries, textile, chemical, fertilizer and other industries.

Expert inputs to CPCB for Sugar Industries & Distillery Industry

The department had given inputs to CPCB for formulating a “Comprehensive charter for effluent treatment by sugar industries situated in the river Ganga Basin” and “Charter for zero liquid discharge in molasses-based distilleries”. The department participated in online meetings for the implementation of these charters through discussion with industry stakeholders and other experts.

Recategorisation of sugar industries for CPCB

Sugar industry is currently included in the red category of highly polluting industries however its environmental performance varies in different units. CPCB has decided to recategorize the sugar mills based on the environmental performance, which includes water usage, quantity and quality of wastewater generation, performance of ETP, recycling, etc. The department worked with CPCB for this recategorization and gave the expert inputs. Staff of the department prepared the draft for the criteria to be used for recategorisation.

Formulation of norms and assessment of data for environmental awards

The Institute started conferring “Late Kisan Mahadeo alias Abasaheb Veer Award for the Best Environmental Conservation” for sugar mills and allied distilleries from the crushing season 2016-17 and an award for best environmental officer/manager from the crushing season 2018-19. The department formulates the norms for this award. Assessment of applications received for both the abovementioned awards from various mills was carried out to identify the best work in environmental conservation and the best environmental manager. The norms for award were revised and questionnaire for applicants was modified accordingly.

Work on selection committees

Staff of the department has been part of interview panel for selection of environmental officer for sugar mills.

Academic

The department conducts M.Sc. (Environmental Sciences) as well as Ph.D. program affiliated to Savitribai Phule Pune University (SPPU). In addition, short term training programs are conducted for a. environmental officers and b. ETP operators

Staffs of the department have been part of academic evaluation for the following Institutes/ Universities as experts/external examiners.

Framing the syllabus as per UGC guidelines following New Education Policy (NEP)

SPPU revised the syllabus for all programs and also changed the structure of these programs as per the

University/ Institute	Examination/evaluation
Department of Environmental Sciences, SPPU	<ol style="list-style-type: none"> 1. PhD admission interviews 2. MSc (Environmental Sciences) dissertation presentation & viva voce
Bharati Vidyapeeth Institute of Environment Education & Research.	<ol style="list-style-type: none"> 1. Pre PhD course work evaluation. 2. MSc (Environmental Science & Technology) dissertation presentation & viva voce
SPPU (All colleges with MSc Environmental Sciences)	<ol style="list-style-type: none"> 1. Coordination of paper setting and central assessment program 2. Coordination of final practical examinations

New Education Policy. Staff of the department contributed to framing of syllabus for B.Sc. & M.Sc. programs in environmental sciences for colleges affiliated to SPPU and New Arts Commerce & Science College, Ahmednagar (an autonomous college under SPPU). One of the staff members of the department is a member of the Board of Studies in environmental sciences at SPPU and also for this college. Detailed structure and syllabus for all four semesters for M.Sc. (Environmental Sciences) for SPPU was also prepared.

Working on the advisory committee of “Ghod River Water Fund”

The Nature Conservancy (TNC) is a global conservation organisation working to conserve lands and water. TNC India is working on a project on “Catalyzing Collective Action for Water Security in Maharashtra” under which they have established

“Ghod River Water Fund” which will showcase a pragmatic, long-term solution that improves lives, provides water security and thus enabling prosperity of the local communities in the region. Dr. Deepali Nimbalkar, Senior Scientist & Head, Environmental Sciences has been included in the advisory committee formed for this project to cover the impact of the sugar industries in the river basin.

Several stakeholder meetings were organized by TNC and the findings were discussed. Based on the preliminary findings of the feasibility analysis and inputs from advisory committee, it was decided to implement the pilots in the upstream area of the Ghod basin. Accordingly pilot sites have been selected. The objective of these pilots is to showcase efficacy of nature based solutions in resolving water security challenges.



Inauguration of National Technology Day by Dr. Rajendra Shende at VSI



Training programme on ‘Pollution control and waste management in distillery units’ officers from CPCB, New Delhi



Visit of Mr. Florent Lacharme, Schneider Global, France

ELECTRONICS AND COMPUTER



ELECTRONICS AND COMPUTER

The department is engaged in R & D and consultancy for the computerization of different user operations in a sugar mill. Several sugar mills are using the software developed by the Institute. The demand for this software has increased considerably and maintenance service for this software is provided by the department. The department is also involved in electronics projects with other departments within the Institute. The staff is engaged in teaching, training, maintaining the Institute's computers and LAN system.

RESEARCH AND DEVELOPMENT

VSI sugar ERP

VSI has developed and implemented a quality software for sugar and allied industry, known as VSI sugar ERP. It was developed in VB/VB.net software language, oracle database and crystal reports. Presently, 25 modules of this software are being used by 100 sugar mills and allied industries.

Advantages of VSI sugar ERP

- The cost of VSI sugar ERP is 50% less than commercial software available in the market.
- The software supports multilingual facilities like Marathi, Kannada, Hindi and Gujarati. The software is user friendly to operate and easy to customize.
- The software helps sugar mill for transparent and systematic work flow, standardization of reports for minimize paper work and MIS reports are available on single click.
- The software is consisting of 25 modules. Capability to integrate all the modules whether installed as a whole or module-wise. It is implemented in 100

sugar mills of Maharashtra, Karnataka, Goa, Gujarat and abroad (Tanzania).

- The software is designed using latest technology like RDBMS database, Dot Net.
- Fully controlled by appropriate authentication and authorization access rights.
- Immediate SMS notification to farmers and H&T-contractors with tonnage details as soon as the vehicle is emptied on weigh-bridge.
- Open-ended design makes further development/enhancements very easy.
- Online refreshing Dash-Board with real-time crushing status, number of vehicles in cane-yard at any moment, raw material (cane) available in cane-yard at any moment, weigh-bridge status.
- Centralized database with security features.
- Reliable, prompt and assured aftersales service to the entire satisfaction of users.
- Better management and full utilization of existing resources.
- Information integration for effective working.
- Flexibility.
- Better analysis and planning capabilities.
- Reports, graphs and charts gives higher performance visibility.
- GST E-invoice enable

The modules installed at different locations during the year are given in table 1, 2 and 3.

Sugarcane management and development

Cane plantations records of many farmers from

Table 1: Installation of modules

Name of Mill	Module Name
Aayan Multitrade	Sugarcane management, weigh bridge, sugarcane farmer billing, harvesting and transport billing, press mud and other sale, financial accounting, sugar sale and godown management, time office, store inventory, purchase and store costing, share
Bagamoyo Sugar	Sugarcane Management, Sugarcane Development, Sugar Manufacturing and Chemical Laboratory Analysis
Bhima MRN	Time office
Ashok SSK	Financial accounting (distillery)
Bhima Shankar SSK	Sugar Manufacturing and Chemical Laboratory Analysis
DudhgangaVedganga SSK	Sugar Manufacturing and Chemical Laboratory Analysis



Table 2: Installation GST Invoice

Name of Mill	Module Name
Cane Agro, Kurumdas	E-invoice

Table 3: Installation VSI Software

	Module Name
VSI Software	Farm expenditure management, Online purchase requisition, Weekly meeting, Sugarcane operation management system, Sugarcane seed available and sale system

various villages have been managed through this module as these records are linked to harvester, transporter, farmer and information regarding cane plantation for issuing field slip. The system was made tamper proof and user friendly. Reports such as variety wise, circle wise, village wise, cane type wise, crop type wise cane plantation were provided. Detailed harvesting program was generated to help in effective implementation increasing the sugar recovery. In addition, recovery based harvesting program facility was provided. Cane plantation registration, cancellation, transfer facility was embodied in the program.

Weigh bridge

Automatic cane weight is being recorded without any intervention through weigh bridge module. This module was designed with new MIS reports due to which management get information at a glance and helps for planning best harvesting schedule to improve recovery. This module provides facility for field slip feeding to ensure error free entry for information pertaining to farmer, harvester, transporter, bullock cart etc. This ensures speedy operation of weigh bridge and avoids malpractices. Weight slip can be edited with proper rights. Facility of recording cane sent to other mills for crushing is also provided. The reports are generated automatically.

Sugarcane farmer billing

New sugarcane farmer billing method was developed which facilitated generation of the bill for any period with facility of determining interest if any. Bill generation for cane supply to other mills is also provided. Facility for cheque printing on pre-printed stationary is also provided. Variety wise bill is possible in the module. Farmer ledger is maintained in cane account. Financial auto voucher facility is also generated

Harvesting and transport billing

A new user-friendly version of harvesting and

transport billing was developed and implemented. It helps the mill to set transporter harvester rate, rate of deposit, rate of commission, facility of billing of harvesting and transporting for cane diverted to other mill, advance balance recovery from linked transporter or harvester etc. This module is linked with cane account and has interface with financial activity and HT billing Ledger is provided to such transporter and harvester. It has now become possible to maintain a single account for a person having different roles such as harvester or transporter or bullock cart operator.

Store inventory, purchase and store accounting

The front-end look of existing store inventory module was modified to make it more effective, impressive and readable. The facility for maintaining separate information for porter and transporter was provided additionally. Some modules were redesigned as per customer specification. In sub module, store costing, a separate option was provided for processing under the heading item transaction processing. It was found useful for displaying reports such as stock ledger, closing stock statement, job wise and main store summary report which reduced the required time for displaying the report.

Sugar sale and godown management

Sugar mills sell sugar by calling tenders. The sugar sale module was modified to incorporate this information. Software was also modified to enable contract with sugar purchaser and automatic maintenance of sugar stock and sugar purchase ledger. Various reports generated such as tender allotment, party wise balance, sale summary, periodic and GST.

Time office

The modifications were made in the Time office software module. Detailed record of grade change, section, designation, bank, increment, payment process locking facility, provision of different type supplement

payment such as retention, back salary, overtime, bonus, reward, leave encashment, PF related reports such as ECR file creation, income tax related reports, auto voucher facility for account, monthly reports of slip, pay sheet (section and department wise summary), bank list (deduction wise, earning wise), PF statement, yearly report of employee (year wise summary, department wise summary, deduction wise summary), all leave balance facility etc.

Financial accounting

The financial accounting software has the facility to operate in bilingual mode i.e. English and local language. Additional improvements such as double entry accounting, financial year wise partitioning, user rights and data security customization based on client requirements, voucher passing level authentication, division wise and consolidated reports maintenance, center wise cost recovery of deduction, cane account system integration with account, interest calculation based on fortnight etc. were made.

Sugar share

This module caters to the requirement of member code, certificate numbers, number of shares, share amount, date of membership, gender, age etc. Election lists and various summary reports for the election can be generated.

Sugar manufacturing and laboratory analysis

This module dealt with the process material, production and progress chemicals etc. in the sugar manufacturing process. It carries out the necessary calculations and produces various reports on sugar production and mill performance.

Press mud and other sale

This module handles activities of molasses, press mud and other sale. This includes invoice, receipts, daily reports, frequently required reports, periodic reports and stock reports.

GST E-invoice

As per GST council, sugar mill has to upload each invoice online with E-way bill. Using invoice facility, sugar mill can upload invoice online as soon as invoice generates along with E-way bill. After uploading sugar mill will issue invoice copy with QR code and E- invoice details such as IRN no., acknowledge no., date etc. Sugar mill can cancel invoice online.

Farm expenditure management

This module dealt with the day-to-day transaction of the farm. It typically allows tracking various expenses such as inputs, equipment maintenance, labor costs, utilities, and other operational expenses, maintain balance and necessary reports for account and farm.

Online purchase requisition

An online purchase requisition system automates the purchasing process by implementing purchase requisition form and providing a central place for the management of all purchase requisition. Employees can create purchase requisitions to purchase goods, material etc. After quotation and respective approval purchase order generated.

Weekly meeting

This software is developed for weekly meeting department reporting. This module records departments weekly income, sale, credit sale, analysis, product sale, visits and other work. All department combine report submit to Director General.

Sugarcane operation management system

This system manages the details of sugarcane crop, sugarcane details, pesticide used, insecticides used, amount of fertilizers used, or to be used. It contains Information about the all VSI Farms and cost of fertilizers etc. The system is built for the farm in-charge to observe sugarcane plot.

Sugarcane seed available and sale system

To overcome manual sugar seed selling process which is time consuming, this system is design. An online registration form collect information and users demand from our web pages to book sugar cane seed/seedling/sugarcane plant. This process is more easy for both user (farmer, sugar mill) and institute.

Consultancy visit to Bagamoyo Sugar, Tanzania

Bagamoyo Sugar Ltd. (BSL) is a sugar manufacturer in Tanzania, the second-largest economy in the East African Community. BSL placed an order for VSI sugarERP software for Agriculture management system, Workshop management, Sugar manufacturing, laboratory analysis and time office. Sugar mill arranged two visits in reporting year.

Mr. A.N. Jamadar, Mr. B.L. Bhosale, Mr. N.M. Patil and Mr. J.A. Chabukshwar visited in reporting year. During the visit, the VSI team designed and modified software as per requirement with the BSL Team.

INSTRUMENTATION



INSTRUMENTATION

The importance of automation in the sugar mills has increased dramatically in recent years. Process automation helps to enhance product quality, plant capacity, improves process safety and efficient utilization of resources. In the rapidly growing sugar, cogeneration, distillery & ethanol plants, quantity & quality production is the key motivation for undertaking process automation. The barriers between technology, communication and automation in the operational context are gradually reducing. The latest technologies include wireless, fieldbus/modbus, cloud networks. The need of training aspects at all levels to increase the awareness of control and instrumentation is felt essential. During the report period, the department has performed activities to implement and improve the status of instrumentation & automation systems in sugar mills, distillery plants which mainly includes extension and advisory services, teaching, training, project consultancy and in-house instrumentation work. These are as briefed below:

Replacement of old PLC systems & its integration with new DCS

During crushing season 2022-23, the LMGP Dnyaneshwar SSK has faced operational problems in PLC based systems of different makes implemented for old distillation, evaporation & ethanol plants. Separate ES-1No. & OS-1No. has been installed for each distillation, evaporation & ethanol plants requiring more attention and maintenance. During the report period, sugar mill has decided to install new distillery, evaporation & ethanol plant and its operations were to be controlled through DCS. In order to avoid the operational & maintenance problems in old PLC systems and to control both distillery plant from single control room, it was decided to replace these systems and integrate them to DCS system having ES-2Nos. & OS-3 Nos. of new distillery plant.

In view of this, the detailed study of existing three PLC system architectures, old plant I/O counts, field instrumentation, cable schedule from JB's to PLC panels was carried out. Accordingly, selection of the DCS controllers, total I/O counts, UPS load, design of DCS panels, centralized DCS control room layout, DCS architecture & development of SCADA screens were

done. These PLC systems were replaced & field instrumentation integrated with new system during erection of new distillery and commissioned successfully through DCS system. This has helped mill to control old as well as new plant through centralized control room, avoid system failures, minimization of maintenance & reduction in man power.

DCS based boiling house automation

In the crushing season 2022-23, KS Kale SSK successfully completed installation & commissioning of new mill, boiler & power house expansion project. During season 2023-24, mill decided to install new boiling house. Sugar mill was having partial stationwise boiling house automation in old plant. Considering the achieved benefits with DCS based automation for mill & boiler, sugar mill decided to install DCS based automation with ES-1 & OS-2 stations for evaporation, pan & clarification. In line with this, the department carried out sizing of two sets of redundant controllers, its hookup diagrams, control & remote panel's layout, finalization of I/O counts, DCS system architecture, boiling house field instrumentation & its control loop logics. During this crushing season, DCS system was commissioned successfully and this helped sugar mill to achieve its higher crushing rates. During the report period, similar guidelines were given to KAT Samarth SSK Unit-I, Vighnahr SSK, Datta SSK; Shirol SSK, KDGDB Lad SSK and Ambalika sugar mills.

Improvements in operational performance of I&C system in incineration boilers

Due to increasing demand of ethanol, sugar mills are installing new or expanding existing distillery plants. In distillery, the disposal of spent wash is critical. Mills install either incineration boiler or dryer for its disposal. In the crushing season 2023-24, Rajarambapu Patil SSK, Unit-I has installed new incineration boiler, turbine & evaporation plant. During commissioning trials of plant, the variations in boiler operational parameters such as pressure, temperature, draft etc & frequent tripping of turbine were noticed. Detailed study for pros & cons of problems was carried out. The necessary corrections in various control loop logics such as PRDs, combustion control, attemperator temperature control, furnace draft etc in DCS were done. This helped sugar mill to minimize the operational



problems of boiler & tripping of turbine. During the report period, similar guidelines are also given to Ashok SSK, Vighnahar SSK, Sharad SSK, Ambalika sugars and LMGP Dnyaneshwar SSK sugar mills.

Project work

Department is instrumental in implementing the measurement and control systems by performing various activities involved as per standard instrumentation practices in sugar, cogeneration, distillery, ethanol & evaporation projects. This mainly includes finalization of technical specifications, inspection, installation, erection & commissioning of various I&C systems. This enables the industry personnel to achieve the desired performance in these plants. As per the requirements, the department carries out various I&C activities involved in following projects:

Distillery projects

- KAT Samarth SSK, Unit-I
- KAT Samarth SSK, Unit-II
- Vilas SSK, Unit-II
- Vighnahar SSK
- Rajarambapu Patil SSK, Unit-I
- Jaywant Sugars
- LMGP Dnyaneshwar SSK
- Pd. Dr. PK Sonhira SSK
- Ashok SSK
- Rena SSK
- Sharad SSK
- KDGDB Lad SSK
- Moharrao Shine SSK
- Kadwa SSK
- Venkateshkruppa Sugars
- Ambalika Sugars
- Sant Tukaram SSK

❖ Modernization / Expansion of sugar plants

- KS Kale SSK
- KAT Samarth SSK, Unit-II
- Vighnahar SSK
- KDGDB Lad SSK
- Swami Samarth Sugar & Agro
- Ambalika Sugars

Microwave based thermostatic irradiation system

The Tissue Culture section & Instrumentation dept of Institute had undertaken R & D project viz. Microwave based thermostatic irradiation system for synthesis of low molecular weight chitosan/ chitosan nano particles with financial funding of MPCB; Mumbai. During the report period, the manufacturing of the PLC based control system and microwave oven started by M/s. Mewag Engineering; Chikhali. The inspections microwave unit & its panel are carried out. The modifications in both are given to M/s. Mewag as per operational requirements. The rectified microwave unit with its control panel will be tested & modified if required, in VSI laboratory during the year 2024-25.

Extension services

In order to improve the working status of I & C systems, the department has given 128 visits to 60 sugar mills during period. During the report period, total 619 instruments of 33 sugar mills were rectified, standardized & commissioned at the mill as well as Institute site and of sugar mill details are as below:

- Daund Sugars
- Vilas SSK, Unit-II
- SMSM Patil SSK
- Ajinkyatara SSK
- Lok. Sundarraoji Solanke SSK
- Lokmangal Sugar & Ethanol
- Saswad Mali Sugar Factory
- Gangakhed Sugar & Energy
- Vitthalrao Shinde SSK, Unit-I
- Vitthalrao Shinde SSK, Unit-II
- Bhaurao Chavan SSK, Unit-I
- Bhaurao Chavan SSK, Unit-II
- Rajarambapu Patil SSK, Unit-II
- VVD Manjara SSSK
- Vtthal Corporation
- Baramati Agro, Unit-III
- SMS Kolhe SSK
- Pandurang SSK
- Sharayu Agro Industries
- Indreshwar Sugar Mills

- Jagruti Sugar & Allied Industries
- Om Datta Enterprises
- Utopian Sugars
- Baramati Agro, Unit-II
- Sahyadri SSK
- Mula SSK
- Jaywant Sugars
- Malegaon SSK
- Datta SSSK; Shirol
- Kunturkar sugar & Agro
- Shreenath Mhaskoba Sugars
- Venkateshkrupa Sugar Mills
- Vilas SSK, Unit-I

Calibration of in-house scientific instruments

- To resolve the operational problems faced by the scientists/ officers of the Institute regarding operations of the scientific instruments, the necessary rectification and calibration services are given by the dept. Total 149 instruments/equipments of 11 laboratories of Institute are rectified & standardized satisfactorily. This mainly includes electronic balance, BOD incubator, spectrophotometer, pH meter, conductivity meter, muffle furnace, centrifuge machine, polarimeter, temperature control unit, liquid filling machines, water bath, air compressor, voltage stabilizer, flame photometer etc.

- In addition to this, in house calibration work of 114 instruments of 7 laboratories was completed as per ISO 9001:2015 requirements.

Academics

The following teaching and training programmes have been conducted by the department during the report period.

- a) Teaching: To the increase the awareness of instrumentation & automation in sugar mill, cogeneration & distillery plants, dept has taken lectures & practicals to various AVSI & University courses- Alcohol Technology, Sugar Engineering PG Diploma, Sugar Engineering Certificate, Sugar Technology, Sugar Manufacturing Certificate & Wine and Brewing Technology conducted by the Institute.
- b) Training: During report period, the dept has conducted two STTP's viz. 'Repairs & Maintenance of Sugar Factory Instruments' & 'Techniques in Analytical Instruments' for instrument engineers / technicians/ mechanics/ DCS operators and lab/ manufacturing chemist related to laboratory & sugar instrumentation systems. Also conducted lectures in six STTPs conducted by Sugar Engineering, Sugar Technology and Alcohol Technology & Biofuels Department.



Visit of Mr. Ravi Kumar (IAS),
Managing Director of the Mysore Sugar Company



Visit of Dr. Michael Butterfield, Data Science and
Scientific Affairs Manager, CTC, Brazil

ANNEXURES



AWARDS OF EXCELLENCE

The Institute recognizes extraordinary performance annually by conferring awards of excellence to the sugar mills, distilleries, employees working in sugar mills, distilleries, farmers and employees of Vasantdada Sugar Institute. The details of the awards for this year are as under:

- LATE KISAN MAHADEV ALIAS ABASAEHB VEER BEST ENVIRONMENTAL CONSERVATION IN MAHARASHTRA
- **Padmashri Dr. D. Y. Patil SSK Ltd., Kolhapur**
- LATE RAOSAHEBDADA PAWAR AWARD FOR THE BEST DISTILLERY IN MAHARASHTRA
- **Sahakar Maharshi Shankarrao Mohite - Patil Ltd., Solapur**
- LATE KARMAYOGI SHANKARRAOJI PATIL AWARD FOR THE BEST FINANCIAL MANAGEMENT IN MAHARASHTRA
- **Daund Sugar, Pune**
- LATE Dr. APPASAHEB ALIAS SR PATIL AWARD FOR THE BEST CANE DEVELOPMENT PERFORMANCE IN MAHARASHTRA (Jointly)
- **Yashwantrao Mohite Krishna SSK Ltd., Satara**
- LATE VILASRAOJI DESHMUKH AWARD FOR THE MOST INNOVATIVE SUGAR FACTORY IN MAHARASHTRA
- **Sahakar Maharshi Shankarrao Kolhe SSK Ltd., Ahmednagar**
- LATE VASANTDADA PATIL AWARD FOR BEST OVERALL PERFORMANCE OF THE SUGAR FACTORY IN MAHARASHTRA
- **Shree Chhatrapati Shahu SSK Ltd., Kolhapur**

The following sugar mills received zone-wise awards for achieving high technical efficiency

Awards for technical efficiency

Prize	Sugar Mill		
	South Zone	Central Zone	North-East Zone
First	Krantiagrani Dr. G.D. Bapu Lad SSK Ltd. Sangli	Ashti Sugar Ltd, Solapur	Rena SSK, Latur Jointly with Vilas SSK Ltd., Unit-I, Latur
Second	Jaywant Sugars, Satara	Bhimashankar SSK Ltd., Pune	Vikasratna Vilasrao Deshmukh Manjara SSK Ltd., Latur
Third	Vishwasrao Naik SSK Ltd., Sangli	Vitthalrao Shinde SSK Ltd. Unit-I, Solapur	Purna SSK Ltd., Hingoli Jointly with Natural Sugar & Allied Industries Osmanabad

Zone-wise awards to sugar mills for best work in cane development and efficient financial management are given below.

Awards for cane development and financial management

Prize	Sugar Mill		
	South Zone	Central Zone	North-East Zone
Cane Development	Krantiagrani Dr. GD Bapu Lad SSK Ltd., Sangli	Vitthalrao Shinde SSK Ltd., Solapur	Karmayogi Ankushrao Tope Samarth SSK Ltd., Jalna
Financial Management	Dr. Patangrao Kadam Sonhira SSK Ltd., Sangli	Bhimashankar SSK Ltd., Pune	Rena SSK Ltd., Latur



VSI also gives awards to farmers for achieving highest sugarcane yield at Zonal and State level. The list of awardees is given below:

Awards for season-wise highest sugarcane yield in the zone and state

Name of Farmer and Sugar Mill	Sugarcane Variety	Yield (t/ha)	Name of Award
SOUTH ZONE			
Mr. Suhas Madhukant Patil Dr. Patangrao Kadam Sonhira SSK Ltd., Sangli	Co 86032	299.24	First in Pre-seasonal planting
-----	-----	-----	First in Seasonal planting
Mr. Sambhaji Rangrao Patil Rajarambapu Patil SSK Ltd. Unit No.1, Sangli	Co 86032	221.36	First in Ratoon
CENTRAL ZONE			
Mr. Vijay Sivilal Lokare Vithalrao Shinde SSK Ltd., Solapur	CoM 0265	314.58	First in Pre-seasonal planting
Mr. Sunil Govind Kakade Shri. Vighnagar SSK Ltd., Pune	Co 86032	215.34	First in Seasonal planting
Mr. Suresh Jalindar Aavare Vithalrao Shinde SSK Ltd., Solapur	CoM 0265	239.52	First in Ratoon
NORTH EAST ZONE			
-----	-----	-----	First in Pre-seasonal planting
-----	-----	-----	First in Seasonal planting
Mr. Bhairavnath Raghunath Savase Vilas Sahakari Sakhar Karkhana SSK Ltd., Latur	Co 86032	215.40	First in Ratoon
STATE			
Mrs. Vimal Laxman Chogule. Sharad SSK Ltd., Kolhapur	Co 86032 (Pre-seasonal)	371.40	Late Yashwantrao Chavan
Mr. Popat Tukaram Mahabare Shri. Vighnagar SSK Ltd., Pune	Co 86032 (Suru)	216.35	Late Vasantnao Naik
Mr. Aniket Hanumant Bavkar Shri. Sant Tukaram SSK Ltd., Pune	Co 86032 (Ratoon)	291.81	Late Annasaheb Shinde

Note: As per rules and regulations of the Institute no farmer was found eligible for *Oos Bhushan* award for seasonal in south zone and pre-seasonal & seasonal planting in north-east zone.

The outstanding performance by individuals in their field of work is recognized by the Institute by way of individual awards. The following individuals received awards for their performance.

Awards for outstanding performance

Award	Awardees and Organization
Best Managing Director	Mr. Rajendra N. Yadav, Shri Someshwar SSK Ltd., Pune
Best Finance Manager	Mr. Ravindra M. Kakade, Karmayogi Sudhakar Rao Paricharak Pandurang SSK Ltd., Solapur
Best Chief Chemist	Mr. Kiran R. Patil, Krantiagrani Dr. GD Bapu Lad SSK Ltd., Sangli
Best Chief Engineer	Mr. Suryakant K. Godse, SM Shankarrao Mohite-Patil SSK Ltd., Akluj, Solapur.
Best Distillery Manager	Mr. Dattatray M. Vare, Loknete Sunderraoji Solanke SSK Ltd., Beed
Best Environmental Officer	Mrs. Deepa S. Bhandare, Shri Datta Shetkari SSK Ltd., Kolhapur
Best Cane Development Officer	Mr. Prashant B. Kanase, Dr. Patangrao Kadam Sonhira SSK Ltd., Sangli
Best VSI Employee(s)	Mr. Deepak N. Shitole, Sr. Sugar Engineer, Sugar Engineering Department
	Mr. Sanjay A. Dawari, DTP Operator, Art & Graphics Division
	Mr. Dhanraj M. Mohite, Clerk Cum Record Keeper, Account Department
	Mr. M.S. Panchal, Carpenter, Estate & Hostel Department

Annual Awards for the year 2022-23



Mr. Sharad Pawar, Hon. Former Minister for Agriculture and Food Processing Government of India and President, VSI, addressing Annual General Meeting

Mr. Sharad Pawar, Hon. President, VSI and other dignitaries release Technical Performance of Sugar Mills in Maharashtra Publication of VSI during Annual General Meeting



Mr. Sharad Pawar, Hon. President, VSI and other dignitaries release Financial Performance of Sugar Mills in Maharashtra Publication of VSI during Annual General Meeting

Mr. Sharad Pawar, Hon. President, VSI and other dignitaries release Technical Performance of VSI Member Distilleries in Maharashtra Publication of VSI during Annual General Meeting



Late Dr. Vasantdada Patil Award for the Best Overall Performance being presented to Shree Chhatrapati Shahu SSK Ltd., Kolhapur



Annual Awards for the year 2022-23

Late Vilasrao Deshmukh Award for Most Innovative Factory being presented to Sahakar Maharshi Shankarrao Kolhe SSK, Ahmednagar



Late Dr. Appasaheb alias SR Patil Award for Best Cane Development Performance being presented to Yashwantrao Mohite Krishna SSK, Satara



Late Karmayogi Shankarrao Patil Award for Best Financial Management being presented to Daund Sugar Pvt. Ltd., Pune



Late Kisan Mahadev Alias Abasaheb Veer Award for Best Environmental Conservation being presented to Padmashri Dr. DY Patil SSK, Kolhapur

Late Raosahebada Pawar Award for Best Distillery being presented to SM Shankarrao Mohite Patil SSK, Solapur



Annual Awards for the year 2022-23



◀ Technical Efficiency Award (South Zone) being presented to Krantiagrani Dr. GD Bapu Lad SSK, Sangli

▶ Technical Efficiency Award (Central Zone) being presented to Ashti Sugar Ltd. Solapur



◀ Technical Efficiency Award (North-East Zone) being presented to
1) Rena SSK, Latur Jointly

▶ Technical Efficiency Award (North-East Zone) being presented to
2) Vilas SSK Unit-I, Latur Jointly



◀ Financial Management Award (South Zone) being presented to Dr. Patangrao Kadam Sonhira SSK, Sangli



Annual Awards for the year 2022-23

Financial Management Award (Central Zone) being presented to Bhimashankar SSK, Pune ▶



Financial Management Award (North-East Zone) being presented to Rena SSK, Latur ◀

Cane Development Award (South Zone) being presented to Krantiagrani Dr. GD Bapu Lad SSK, Sangli ▶



Cane Development Award (Central Zone) being presented to Vitthalrao Shinde SSK, Solapur ◀

Cane Development Award (North-East Zone) being presented to Karmayogi Ankushrao Tope Samarth SSK Unit-I, Jalna ▶



Annual Awards for the year 2022-23



◀ Oos Bhusan (Late Yashwantrao Chavan Award) being presented to Mr. VL Chaugule, Sharad SSK, Kolhapur

Oos Bhusan (Late Vasantnaik Award) being presented to Mr. PT Mahabare, Shri Vighnahar SSK, Pune ▶



◀ Oos Bhusan (Late Annasaheb Shinde Award) being presented to Mr. AH Bawkar, Shri Sant Tukaram SSK, Pune

Best Managing Director Award being presented to Mr. RN Yadav, Shri Someshwar SSK, Pune ▶



◀ Best Agriculture Officer Award being presented to Mr. PB Kanase, Dr. Patangrao Kadam Sonhira SSK, Sangli



Annual Awards for the year 2022-23

Best Chief Engineer Award
being presented to Mr. SK Godse,
SM Shankarrao Mohite-Patil SSK, Solapur



Best Chief Chemist Award
being presented to Mr. KR Patil,,
Krantiagrani Dr. GD Babu Lad SSK, Sangli

Best Distillery Manager Award
being presented to Mr. DM Vare,
Loknete Sunderraoji Solanke SSK, Beed



Best Finance Manager Award
being presented to Mr. RM Kakade,
Karmayogi Sudhakarant Paricharak Pandurang SSK,
Solapur

Best Environmental Award
being presented to Mrs. DS Bhandare,
Shri Datta Shetkari SSK, Kolhapur



Annual Awards for the year 2022-23



◀ Best Employee Award (VSI)
being presented to
Mr. DN Shitole, Sr. Sugar Engineer
(Sugar Engineering Department)

Best Employee Award (VSI)
being presented to Mr. SA Dawari, DTP Operator
(Art & Graphics Division) ▶



◀ Best Employee Award (VSI)
being presented to
Mr. DM Mohite, Clerk Cum Record Keeper
(Account Department)

Best Employee Award (VSI)
being presented to Mr. MS Panchal, Carpenter
(Estate & Hostel Department) ▶



◀ National Anthem



MEMBERSHIP OF OTHER ORGANIZATIONS

Organization membership

The membership of national and international associations related to sugar and allied industries has renewed. This includes:

National

- Biotech Consortium India Ltd. (BCIL)
- Indian Association of Special Libraries and Information Centers (IASLIC)
- Maharashtra Economic Development Council (MEDC)
- Maratha Chamber of Commerce, Industries and Agriculture (MCCIA)
- Society for Sugarcane Research and Development (SSRD)
- South Indian Sugarcane and Sugar Technologists' Association (SISSTA)
- Sugar Technologists' Association of India (STAI)
- The Energy and Resources Institute (TERI)

International

- Australian Society of Sugarcane Technologists Ltd. (ASSCT)
- International Consortium for Sugarcane Biotechnology (ICSB)
- International Society of Sugar Cane Technologists (ISSCT)
- Sugar Industry Technologists Inc. (SITI)
- World Association of Beet and Cane Growers (WABCG)



Visit of Dr. Imad Eujayl, Research Molecular Biologist, USDAARS, USA



Felicitation of Mr. Vikas Patil, Director, Input and Quality Commissionerate of Agriculture, Pune, Govt. of Maharashtra on the occasion of National Seed Day



VSI OFFICIALS ON VARIOUS COMMITTEES

Mr. Sambhaji Kadupatil, Director General

- Member, International Consortium for Sugarcane Biotechnology (ICSB)
- Member, International Society of Sugar Cane Technologists (ISSCT)

Mr. Shivajirao Deshmukh, Advisor

- Member, International Society of Sugar Cane Technologists (ISSCT)
- Member, Screening Committee, Sugar Development Fund (SDF), Government of India
- Member, Executive Committee, Yashwantrao Chavan School of Rural Development, Shivaji University, Kolhapur
- Member (Group of expert), Committee appointed by Punjab State Federation of Co-operative Sugar Mills Ltd. for revival of old sugar mills
- Member, Command Area Water Productivity Working Group, Government of Maharashtra
-

AGRICULTURAL SCIENCES AND TECHNOLOGY

Dr. AD Kadlag, Principal Scientist

- Indian Phytopathological Society (IPS)

Mr. PP Shinde, Scientist

- Member-Command Area Water Productivity Group, Government of Maharashtra.
- Member- Study Group for trash issue of cane harvested by harvesting machines formulated by Commissioner of Sugar, Government of Maharashtra

Mr. BJ Takalkar, Scientific Officer

- Member, Advisory Committee, All India Radio and Television

Ms. SD Ghodke, Head & Scientist

- Member of ICUMSA, National Committee
- Member of STAI Member of SISTA

Dr. SG Dalvi, Tissue Culture

- Advisory Committee Member, Ph. D. & M.Sc. in Agronomy DBSKV, Dapoli
- Advisory Committee Member, M.Sc. in Plant Pathology & Agri Microbiology, MPKV, Rahuri
- Member, Board of Studies Agronomy Dept. Dr. Balasaheb Sawant Konkan Krushi Vidyapeeth, Dapoli
- Member, Board of Studies Plant Pathology & Agri. Microbiology, Mahatma Phule Vidyapeeth, Rahuri



Annexure III (Contd.)

SUGAR TECHNOLOGY

Dr. R V Dani, Head & Technical Adviser

- Member, Project Review & Steering Group meeting, Department of Information Technology, Government of India, New Delhi
- Member, Bureau of Indian Standards (BIS)- FAD2 committee
- Member, Expert Committee formed by CPCB for clean Ganga Mission

SUGAR ENGINEERING

Mr. R A Chandgude, Head & Technical Adviser

- Member, Co-generation Project Implementation And Coordination Committee, Government of Maharashtra
- Member, State Level Machinery Purchase Committee (SLMPC), Government of Maharashtra
- Member, Energy and Cost Audit Committee, Government of Maharashtra
- Member, Committee appointed by Government of Maharashtra for expansion of bagasse based co-generation projects under renewable energy policy
- Member, Committee for boot basis co-generation projects
- Council member, Deccan Sugar Technologist's Association (DSTA) for year 2022-26
- Member, The National Centre for Cooperative Education for Development of sugar Sector Specific Training Modules

ALCOHOL TECHNOLOGY AND BIOFUELS

Dr. KS Konde, Head, Professor & Technical Adviser

- Member, State Level Machinery Purchase Committee (SLMPC)
- Member, High Level Committee to promote biofuel industries of Maharashtra, Government of Maharashtra
- Experts, National Co-operative Resource Centre, Ministry of Co-operation, Government of India
- Member, Committee constituted by CPCB for preparation of charter

Mr. DA Patil, Asst. Professor & Joint Technical Adviser

- Nodal Officer for GPI, Central Pollution Control Board

ENVIRONMENTAL SCIENCES

Dr. DS Nimbalkar, Head & Senior Scientist

- Member, Advisory Committee, Ghod River Water Fund, The Nature Conservancy
- Member, Committee constituted by CPCB for preparation of charter
- Member, Board of Studies in Environmental Sciences, Savitribai Phule Pune University & Kavayitri Bahinabai Choudhari North Maharashtra University, Jalgaon
- Vice Chancellor's nominee & Member, Board of Studies in Environmental Sciences, New Arts Commerce and Science College, Ahilyanagar
- Chairman, Examinations of M.Sc. Environmental Sciences, Savitribai Phule Pune University
- Member, Women Complaints Committee, NRC Grapes, Manjari, Pune

PUBLICATIONS

AGRICULTURE SCIENCES AND TECHNOLOGY

Peer review Journals

Bana S, Narute TK, Latake KB, Dalvi SG and Kolase SV (2023)

In *vitro* effect of chitosan nanoparticles on wilt disease resistance of chickpea by seedlings root feeding of *Fusarium oxysporum* f. sp. *Cicero*.
The Pharma Innovation Journal 12(1):1602-1604

Bana S, Dalvi SG and Narute TK (2023)

Role of chitosan nanoparticles in combating *Fusarium* wilt (*Fusarium oxysporum* f. sp. *ciceri*) of chickpea under changing climatic conditions
Journal of Phytopathology 171:(2-3) 67-81

Deore P, Ahammed Shabeer TP, Upadhyay A and Devarumath RM (2024)

Non target influence of imidacloprid residues on grape global metabolome and berry quality with the identification of metabolite biomarkers
Environmental Science and Pollution Research 3: 15770–15787

Deore P, Ahammed Shabeer TP, Upadhyay A, Sharma AK, Devarumath RM and Kale R (2024)

Non-target impact of imidacloprid residues on wine aroma characteristics assessed by GCxGC-TOF/MS analysis and its residual transformation in vinification by UHPLC-Orbitrap-MS analysis
Microchemical Journal 197: 109834

Kale V, Bodake P, Rajemahadik R, More S, Sanap P, Dalvi S, Mhatre P, Thite S and Patil B (2023)

Chitosan fortified briquette implications in water stressed okra (*Abelmoschus esculentus*)
The Pharma Innovation Journal 12(12): 2094-2100

Karamchandani BM, Maurya PA, Awale M, Dalvi SG, Banat IM and Satpute SK (2024)

Optimization of fungal chitosan production from *Cunninghamella echinulata* using statistical designs
3-Biotech14:82

Khare T, Barvkar VT, Devarumath RM and Vinay Kumar (2023)

Osa miR1861e Modulates Sodium Toxicity Responses in Rice Immature Grains via OsGST and OsPILS7b
J Plant Growth Regul (2023) <https://doi.org/10.1007/s00344-023-11193-8>

Patil AS and Pawar GR (2023)

Agronomic assessment of sugarcane genotypes under varied fertilizer levels. *International Journal of Plant & Soil Science*. 35(19) 572-577

Patil AS and Pawar GR (2023)

Influence of different harvesting dates on yield and quality of sugarcane ratoon
Asian Journal of Science and Technology. 14(9), 12714-12716

Patil AS and Pawar GR (2023)

Influence of different sett treatment techniques on yield, quality and economics of the sugarcane
The bioscan 18(1): 35-37

Patil AS, Pawar GR and Thorat SB (2023)

Response of sugarcane cultivars to different irrigation regime under peninsular zone of Maharashtra, India
International Journal of Environment and Climate Change 13(10): 2764-2772

Shinde NA, Kawar PG and Dalvi SG (2024)

Chitosan-Based Nanoconjugates: A promising solution for enhancing crop drought stress resilience and sustainable yield in the face of climate change
Plant Nano Biology 23:100059

Surwase SA, Singh SK, Kadu PR, GP Obi Reddy, Mohekar DS, Naitam RK, Shirale AO and Deshmukh PS (2024)

Studies fertility status of sugarcane growing soils of Rahuri tehsil of Ahmednagar district using Geospatial technologies
International Journal of Research in Agronomy 7(2): 164-168

Surwase SA, Singh SK, GP Obi Reddy, Kadu PR, Mohekar DS, Naitam RK, Konde NM, Aage AB and Deshmukh PS

Characterization and classification of soils in a toposequence of the semi arid basaltic landscape of western India
International Journal of Plant and Soil Science. Vol.35 (19), pp 876-887.

Thorat BS, Pawar GR, Sushir KV, Talekar SD, Repale JM and Kadlag AD (2024)

Sugarcane: A climate resilient divine crop
International Journal of Environment and Climate Change 14(3): 555-577



Wakchaure GC, Minhas PS, Satish Kumar, Khapte PS, Dalvi SG, Rane J and Sammi Reddy K. (2023)
Pod quality, yields responses and water productivity of okra (*Abelmoschus esculentus L.*) as affected by plant growth regulators and deficit irrigation
Agricultural Water Management 282:108267

REVIEW ARTICLE AND BOOK CHAPTER

Nikhar CK, Vyas GS, Dalvi RS, and Dalvi SG (2023)
Unlocking the potential of adsorption in distillery wastewater treatment: A comprehensive review
Water conservation Science and Engineering (2023) 8:36.

Suprasanna P, Mirajkar SJ, Purankar MV, Nikam AA, Dalvi SG, Vaidya ER and Devarumath RM (2023)
Induced mutation technology for sugarcane improvement: status and prospects
In: Suprasanna P, Jain SM (Eds), *Mutation Breeding for Sustainable Food Production and Climate Resilience*, Springer Nature, Singapore Pte Ltd. pp. 645-668

PAPERS PRESENTATION IN CONFERENCES

Dalvi SG (2023)
Sustainable crop production in onion using bio-stimulants nano formulation
Proceeding of National Symposium cum Industrial Meet on Agri-Business in Alliums: Innovations, Promotions & Sustainability. 22-23 Dec. 2023
Organized by MCCIA Pune and DOOGR Rajgurunagar

Dalvi SG, Ithape DM, Mehtre SJ and Kadlag AD (2023)
Revolutionizing agriculture: Harnessing biosolids for sustainable waste management and crop productivity enhancement
52nd Annual Convention of SISSTA's, pp 162-168

Dalvi SG, Ithape DM, Mehtre SJ and Kadlag AD (2023)
Revolutionizing agriculture: harnessing biosolids for sustainable waste management and crop enhancement
52nd Annual Convention of SISSTA's, pp 162-168

Gaikwad SD, Ghodke SD and Manjul US (2023)
Evaluation of entomopathogenic fungi and their consortium for the management of sugarcane white fly (*Aleurolobus barodensis* Maskell)
52nd Annual Convention of SISSTA's, pp 131-137

Ghodke SD, Nigade KG and Manjul US (2023)
Effect of application of different entomopathogenic fungi and entomopathogenic nematode for control of white grub in sugarcane crop
52nd Annual Convention of SISSTA's, pp 119-126

Ghodke SD, Nigade KG, Manjul US, Jadhav DS and Kamble KB (2023)
Effect of application of different entomopathogenic fungi (EPF) and entomopathogenic nematodes (EPN) for control of white grub in sugarcane crop
52nd Annual Convention of SISSTA's, pp 119-126

Ghodke SD, Nimbalkar D, Nigade KG, Alhat E, Uphade K and Shaikh F (2023)
Evaluation of developed consortium of isolated efficient bacteria on physico-chemical properties of sugar effluent
52nd Annual Convention of SISSTA's, pp 218-225

Hapase RS (2023)
CoVSI 18121 An erect growing, promising sugarcane genotypes for higher cane productivity in Peninsular Zone.
81st Annual Convention of STAI, pp 87-95

Hapase RS (2023)
Evaluation of promising sugarcane genotypes for cane and sugar yield in southern region of Maharashtra
52nd Annual Convention of SISSTA's, pp 51-57

Kotgire GS, Pawar BH, Dalvi SG and Atre GE (2023)
Antifungal efficacy of Silver nanoparticles against *Fusarium moniliformae* - an incitant of pokka beong disease in sugarcane
52nd Annual Convention of SISSTA's, pp 138-149

Mali BG and Ghodke SD (2023)
Isolation and characterization of Manganese Solubilizing bacteria for increasing availability of manganese in sugarcane
81st Annual convention, STAI

Nigade KG, Manjul US and Ghodke SD (2023)
Bio-control of root feeding white grub larvae through application of entomopathogenic nematodes in sugarcane field
52nd Annual Convention of SISSTA's, pp 40-44

Repale JM and RS Hapase (2023)
Evaluation of promising sugarcane genotypes at VSI
81st STAI Annual Convention of STAI, pp 46-50

Repale JM and Hapase RS (2023)
Potential of sugarcane clones for yield and quality traits in Maharashtra.
52nd Annual Convention of SISSTA's, pp 45-50

Shinde PP (2023)

Effect of mulching on cane yield and water use efficiency of sugarcane under drip and surface irrigation.
81st Annual Convention of STAI, pp 3-6

Shinde PP (2023)

Performance evaluation of microirrigation systems in sugarcane crop
52nd Annual Convention of SISSTA's, pp 81-84

POSTER/ABSTRACT PRESENTATION IN CONFERENCES

Chavan RP, Shinde NS, and Dalvi SG (2023)

Unveiling the impact of gamma- irradiated-chitosan nanoparticles on anthocyanin production in *ocimum sanctum* L. callus: a versatile biomolecule
International conference Innovations in Food Processing Technology and Nutrition 22- 24 January 2024, Organized by Dept of Biosciences and Technology, DR.V.K. MIT Peace University Pune in Collaboration with School of Food Technology and Nutrition Loyala Academy, Hyderabad

Chavan RP, Shinde NA and Dalvi SG (2024)

Unveiling the impact of gamma-irradiated-chitosan nanoparticles on anthocyanin production in *Ocimum Sanctum* L. callus: A versatile biomolecule
International Conference on Innovations in Food Processing Technology and Nutrition January 22-24, 2024, jointly organized by the Department of Biosciences and Technology, School of Sciences and Environment Studies, MIT World Peace University, Pune and School of Food Technology and Nutrition, Loyala Academy, Hyderabad

Chavanke S, Dalvi SG and Pawar BH (2023)

Nano-biotechnological approach for sustainable disease management in sugarbeet cultivation under changing climate
6th International Conference On Recent Trends In Bioengineering (ICRTB 2023) 20th - 21st January 2023 at MIT School of Bioengineering & Research, Pune

Dalvi SG (2024)

Synergizing gamma radiations and natural polymers: a novel approach to enhance agricultural sustainability amidst climate challenges
International Conference on Innovations in Food Processing Technology and Nutrition January 22-24, 2024, jointly organized by the Department of Biosciences and Technology, School of Sciences and Environment Studies, MIT World Peace University, Pune and School of Food Technology and Nutrition, Loyala Academy, Hyderabad

Deshmukh PS, Surwase SA and Kharade JP (2023)

Nutrient management in sugarcane growing calcareous soil 52nd Annual Convention, SISSTA

Ithape DM, Dalvi SG and Srivastava A (2024)

Synergistic effect of irradiated chitosan and thiourea on the yield parameters of sugarcane under water-deficient conditions
International Conference on Innovations in Food Processing Technology and Nutrition January 22-24, 2024, jointly organized by the Department of Biosciences and Technology, School of Sciences and Environment Studies, MIT World Peace University, Pune and School of Food Technology and Nutrition, Loyala Academy, Hyderabad

Khandagale K, Dalvi S, Khambalkar P, Bhangare I, Anusha R, Kale R and Gawande, S (2023)

Electron Beam Irradiated Chitosan-Nano Conjugate Promotes Growth and Stemphylium Leaf Blight Resistance in Onion
3rd National Symposium On Emerging Technologies and Trends in Sustainable Production and Value Chain Management of Onion, Garlic and Other Allium Species at Jain Irrigation Systems Ltd. Jalgaon. Feb. 2023 (Best Poster Award)

Kharade JP and Deshmukh PS (2023)

Impact of micronutrient application through soil and drip fertigation on growth and yield of sugarcane, 52nd Annual Convention of SISSTA

The following technical poster presented in the 3rd International Conference and Exhibition at VSI during 12th - 14th January 2024

Bhosale RS, Waghmare KS and Sawant RA (2024)

Protocol optimization for in vitro mass propagation of two varieties of sugarcane
pp 23

Chavanke SN, Dalvi SG, Kotgire GS and Pawar BH (2024)

Nanotechnological advancement in combating *S. rolf sii* causing disease: Novel biopolymeric nanocomposite for sustainable management
pp 19

Darekar AD, Deshmukh PS, Konde KS, Sable SK, Kharade JP and Surwase SA (2024)

Fertilizer use efficiency in table beet as influenced by levels of pdm and muriate of potash
pp 51



Deshmukh PS, Andhale A. and Kharade JP (2024)

Effect of ZEBA on growth, yield and quality of sugarcane
pp 43

Deshmukh PS, Naitam RK, Hingmire VB and Bramhe SB

Geostatistical modeling and soil fertility assessment for sugarcane crop in tropical region of Maharashtra
pp 48

Deshmukh PS, Naitam RK, Surwase SA, Warhade RM and Kharade JP

Characterization and classification of soils of VSI research farm, Nagpur, Maharashtra
pp 45

Ghige U, Purankar MV, Gawali HP and Devarumath RM (2024)

Genomic variation analysis in sugarcane mutant germplasm by lignin pathway related target region amplification polymorphism (TRAP) molecular markers
pp 28

Ghodke SD and Mali BG (2024)

Effect of application of consortium of agriculturally beneficial soil microbes and microbial consortium of endophytes nitrogen fixing bacteria on yield and quality of sugarcane in nutrient exhausted soil
pp 91

Ghodke SD, Nigade KG, Jadhav DS and KB Kamble (2023)

Effect of application of consortium of endophytic bacteria on nitrogen fixation and growth of sugarcane
pp 84

Ghodke SD, Nigade KG and Manjul US (2024)

Effect of application of different entomopathogenic fungi (EPF) and entomopathogenic nematode (EPN) for control of white grub in sugarcane crop

Ghodke SD, Nigade KG, Manjul US, Jadhav DS and Kamble KB (2024)

Effect of application of different biocontrol agents for controlling white grub pest in sugarcane
pp 85

Ghodke SD and Shinde A (2024)

Evaluate the effect of consortium of halophilic and halotolerant microorganisms on reclamation of salt affected soil to increase crop production
pp 83

Hapase PR (2024)

Response of sugarcane varieties in water stress condition
pp 17

Hingmire V, Deshmukh PS, Sable SK and Darekar A (2024)

Effect of foliar application of nanosilica along with oligochitosan on growth, yield and quality of sugarcane
pp 50

Kotgire GS, Pawar BH, Dalvi SG and Yadav JH (2024)

Efficacy of irradiated chitosan (Nano particles) in combination with silver nanoparticles
pp 109

Kovhale M, Dalvi S, Dalvi V, and Bodke P (2024)

Effect of Vasant Urja for sustainable groundnut production
pp 20

Kumar A, Madhavi Y. Ghan MY, and Devarumath RM (2024)

A prominent role of the ATL-NCS-TCP project in ensuring testing, certification, and micropropagation of virus-free commercial elite clones
pp 25

Mali BG, Ghodke SD and Shradha B and Shinde SB (2024)

Study of exopolysaccharide producing bacteria from sugarcane rhizosphere and their impact on growth, yield and quality of sugarcane varieties under water stress condition in pot culture
pp 90

Nigade KG, Ghodke SD, Manjul US, Jadhav DS, and Kamble KB (2024)

Bio-efficacy of entomopathogenic nematode against white grub pest in sugarcane
pp 86

Manjul US, Sushir KV Talekar SD and Kadlag AD (2024)

Screening of sugarcane germplasm for woolly aphid, *Ceratovacuna lanigera* Zehntner
pp 111

Mutkule US, Sable SK, Surwase SA, Deshmukh PS and Bramhe SB (2024)

Optimization of dose of multinutrient liquid fertilizer for sugarcane crop by using drone technology
pp 47

Patil AS, Mundhe AG and Pawar GR (2024)

Performance of Legume Crops under Sugarcane Based Inter-Cropping System
pp 130

Patil AS, Pawar GR and Kadlag AD (2024)

Technological Intervention for Wider Adoptability of Sugarbeet: A case study
pp 69

Patil AS, Pawar GR and Kadlag AD (2024)

Sugarbeet: Climate Resilient Crop for Rainfed Area
pp 70

Patil PB, Patil SD and Dalvi SG (2024)

Revolutionizing sugarcane micropropagation: Vasant Urja as biostimulant for improving the process as well as product with nanobiotech approaches
pp 24

Pawar BH, Kotgire GS and Yadav JH (2024)

Management of brown spot disease in sugarcane
pp 110

Pisal S, Nigade KG and Ghodke SD (2024)

Plant growth promoting rhizobacteria: the novel isolates for biosynthesis of phytohormones and its impact on sugarcane growth
pp 89

Purankar MV, Jagdale MM and Devarumath RM (2024)

Spatio-temporal analysis of sucrose metabolising enzymes in selected salt tolerant mutant clones of Co 86032 and CoM 0265 varieties under control and saline conditions
pp 27

Repale JM, Karade SS, Jadhav DB, Kamble MB and Gawhane AB (2024)

Assessment of promising sugarcane genotypes for productivity and quality in South Maharashtra
pp 15

Shaikh F, Nigade KG, Ghodke SD, Nimbalkar D, Alhat E and Uphade K (2024)

Effect of developed microbial consortium on sugar effluent in aerobic treatment
pp 87

Shinde NA, Dalvi SG and Kawar PG (2024)

Deciphering the potential of gamma-irradiated-chitosan in alleviating the moisture stress tolerance on In Vitro sugarcane plants
pp 21

Shinde PP (2024)

Efficient water management through micro irrigation systems in sugarcane crop
pp 62

Shinde PP (2024)

Increasing water use efficiency through trash mulching in sugarcane crop under drip and surface irrigation
pp 63

Shinde SB, Mali BG and Ghodke SD (2024)

Effect of application of microbial slurry containing natural agricultural beneficial microorganisms on yield and quality of sugarcane
pp 88

Shinde BD, Shitole TD and Dalvi SG (2024)

Chitosan-enhanced growth media for improved biocontrol potential of *Bacillus thuringiensis* subspecies *krustaki*: A Comprehensive evaluation
pp 112

Shitole TD and Yadav RG (2024)

Screening of sugarcane genotype for their reaction against major insect pests in MLT *Adsali*
pp 114

Surwase SA, Deshmukh PS and Kharade JP (2024)

Nutrient management in sugarcane growing calcareous soil
pp 46

Sushir KV, Repale JM, Talekar SD, Manjul US and Kadlag AD (2024)

Breeding for multipurpose canes
pp 16

Talekar SD, Repale JM, Sushir KV, Manjul US and Kadlag AD (2024)

Evaluation and identification of climate resilient ISH and IGH genetic stocks for drought tolerance
pp 18

Walte SS, Repale JM and Gawhane AB (2024)

Selection of sugarcane genotypes for yield and quality in North-East region of Maharashtra
pp 13

Warhade RM, Deshmukh PS, Surwase SA, Darekar AD & Undre BV (2024)

Biochar production from sugarcane bagasse & its sustainable approach for soil management
pp 44



Warpe NA, Kumar A, Kolekar RM, Patil SM and Devarumath RM (2024)

Molecular detection of sugarcane bacilliform virus, sugarcane yellow leaf virus, and sugarcane mosaic virus in sugarcane
pp 26

Yadav RG and Shitole TD (2024)

Screening of sugarcane genotype for their reaction against major insect pests in AVT
pp 113

POPULAR ARTICLE

Deshmukh PS, Surwase SA and Kadlag AD (2023)

Purvahangami osasathi akatmik anndravya vyvasthan
Agrowon, Oct. 9, 2023

Ghodke SD and Nigade K (2023)

VSI nimit jaivik kid niyantranka dware oosatil humaniche niyantran
VSI Bulletin 23(3): 30-31

Kadlag AD and Ghodke SD (2023)

Jivanu Samuhamule 75 takkyaparayant natra bachatichi shakyata
Agrowon, Sakal, Jun 17, 2023

Kotgire GS and Pawar BH (2023)

Unhali hangamat oos pikavaril roganche niyantran
Agrowon, April 12, 2023

Kotgire GS and Pawar BH (2023)

Oosavaril red rot, yellow leaf disease ani mar roganche niyantran
Agrowon, April 29, 2023

Kotgire GS and Pawar BH (2023)

Oos benyadvare pasarnare rog aani tyanche niyantran
Agrowon, May 12, 2023

Kotgire GS and Pawar BH (2023)

Oos pikavar distoy pokkah boeng ani tambera cha pradurbhav
Agrowon, September 30, 2023

Kotgire GS and Pawar BH

Oos pikavar thandicha parinaam aani upayojana
Agrowon, Jan. 21, 2024

Pawar BH and Kotgire GS (2023)

Oos pikachya panawaril rog aani tyanche niyantran
Agrowon, July 22, 2023

SUGAR TECHNOLOGY

Papers in Conference/Seminar

Dani RV and Mahana N (2023)

Comparison of source of CO₂ from flue gas with distillery fermenter gas – in Carbonation Refinery
STAI seminar one day seminar, 2023
pp 9-19

Gangadharam K, Patil RR and Dani RV (2023)

Challenges & remedies in sugar processing during diversion of different feed stocks
52nd Annual Convention of SISSTA held on 29-30 Sept. at Chennai
pp 444-452

Mahana N and Dani RV (2023)

Option to reduce steam % cane during syrup diversion to distillery- case study
81st Annual Convention of STAI held on 6-8 Sept. 2023 at Trivandrum
pp 172-182

Mahana N and Dani RV (2023)

Possibilities of carbonation refinery in Indian context
52nd Annual Convention of SISSTA held on 29-30 Sept. at Chennai,
pp 396-403

Mahana N and Dani RV (2023)

Measures taken to minimize unknown losses- A monetary gain
52nd Annual Convention of SISSTA held on 29-30 Sept. at Chennai
pp 438-443

Mahana N and Dani RV (2023)

Ethanol production-A need of hour for sustainability
52nd Annual Convention of SISSTA held on 29-30 Sept. at Chennai
pp 29-33

Mahana N and Dani RV (2023)

Sulphurless Sugar- Future of India
68th Annual Convention & Sugar Expo of DSTA held on 23-24 Sept. 2023 at Pune
pp 197-204

Mahana N and Dani RV (2023)

Juice extraction system-diffuser a comparative study on milling versus diffuser
68th Annual Convention & Sugar Expo of DSTA held on 23-24 Sept. 2023 at Pune
pp 261-275

Mahana N and Dani RV (2023)

Carbonation Vs Phosphatation in Indian context
SASSTA Seminar 2023
pp 48

Panda S, Mahana N and Dani RV (2023)

Replacement of syrup by clear juice to melt B and C sugar: effect on steam consumption and sugar quality
SASSTA Seminar 2023
pp 65

Panda S and Dani RV (2023)

Advantages of dilution of Syrup by filtrate juice for ethanol production - Case Study
52nd Annual Convention of SISSTA held on 29-30 Sept. at Chennai
pp 431-437

Panda A, Mahana N and Dani RV (2023)

A positive approach to improve sugar quality and reduction in steam consumption – case study
68th Annual Convention of DSTA
pp 180-190

Panda S, Mahana N and Dani RV (2023)

Mindset change from milling to diffuser technology for better extraction in the Indian sugar industry-Case study
52nd Annual Convention of SISSTA's
pp 345-354

Patil RR and Dani RV (2023)

Balancing of evaporator during diversion of feed stocks
52nd Annual Convention of SISSTA's
pp 166

POSTER/ABSTRACT PRESENTATION IN CONFERENCE

The following technical poster presented in the 3rd International Conference and Exhibition at VSI during 12th - 14th January 2024

Chavan ST and Dani RV (2024)

Need of food safety, HACCP & GMP for sugar ethanol industry
pp 170

Ghorpade RN and Dani RV (2024)

Steps from milling to curing -To control final molasses quantity & apparent purity
pp 169

Gangadharam K and Dr. Dani RV (2024)

Resin selection criteria for I.E.R columns in sugar refining
pp 163

Mahana N and Dani RV (2024)

CO₂ from boiler flue gas Vs distillery fermenter gas-in carbonation refinery
pp 164

Mahana N and Dani RV (2024)

Material balance during production of refined sugar without decolorisation
pp 165

SUGAR ENGINEERING

Papers in Conference/Seminar

Chandgude RA and Shripatanala SS (2023)

Promotion of ethanol production: A lucrative evaluation for the sugar industry
One-day joint seminar of SISSTA and SNSI on 'Promotion of Ethanol Production in the Present Scenario of the Indian Sugar Industry' at S. Nijalingappa Sugar Institute, Belagavi on April 1, 2023
pp 98-107

Chandgude RA, Dhage AP, and Rao SM (2024)

Potential for green hydrogen generation in the sugar industry
pp 51-56

&

Patil PG and Rao SM (2024)

Power loss recovery from slip ring motor starter,
pp 63-66
One-day Joint Seminar on 'Modern Technology and Energy Efficient Equipment and Machinery for the Energy Economy' in association with SEDL and Ponni Sugars (Erode) at Tiruchengode, Tamil Nadu, on March 16, 2024

POSTER/ABSTRACT PRESENTATION IN CONFERENCE

The following technical poster presented in the 3rd International Conference and Exhibition at VSI during 12th - 14th January 2024

Bankar Ankush, Bankar Akshay, Chandgude RA (2024)

Unveiling the advantages of the tooth roller juice extractor in sugar processing
pp 148

Chandgude RA, Shitole DN and Nimbalkar Deepali (2024)

Influence of high-pressure heaters in a modern cogeneration system
pp 148

Chandgude RA, Patil PG, Dhage AP and Rao SM (2024)

Multiple avenues of green hydrogen generation in sugar mills
pp 153



Dhage AP, Deshmukh PU and Chandgude RA (2024)
Bagasse saving in the sugar mill
pp 154

Kotkar AB, Thorat SB and Chandgude RA (2024)
Training and development for sugar mills technical staff, unskilled and skilled manpower
pp 156

Nalawade SP, Shitole DN and Chandgude RA (2024)
Selection of conveying system chains in sugar mills
pp 149

Patil PG and Rao SM (2024)
Slip power recovery system for slip-ring induction motor
pp 151

Sastry SS and Chandgude RA (2024)
Effective torque transmission through ropeless coupling
pp 150

Shitole DN, Choudhari TA, Kaduskar SG and Chandgude RA (2024)
Study of the combustion control system of bagasse fired boiler for sugar and cogeneration plant
pp 158

Takale R and Chandgude RA (2024)
Sustainable irrigation by using off grid standalone solar power system to agriculture pumps, case study
pp 152

Taur MV, Thorat SB and Chandgude RA (2024)
Adoption of safety measures in sugar mills
pp 155

ALCOHOL TECHNOLOGY & BIOFUELS

Book Chapter

Nalawade, K, Saikia P, Singh S, Behera S, Konde K, and Patil S (2023)
Utilization of plant-derived wastes for value added product formation. In waste valorization for value-added products, Bentham Science Publisher
pp 1-36

Nalawade, K, Kadam V, Behera S, Konde K, and Patil S (2023)
Mechanisms and applications of biofuel: Acetone-Butanol-Ethanol fermentation. In Sustainable Butanol Biofuels, CRC Press,
pp 121-145.

POSTER/ABSTRACT PRESENTATION IN CONFERENCE

The following technical poster presented in the 3rd International Conference and Exhibition at VSI during 12th - 14th January 2024

Barguje K, Behera S, Pawar J, Naik N and Konde K (2024)
Microbial process for the production of butanol: A value addition to the sugar industry
pp 176

Behera S, Ghule V, Sangle D, Pawase A, Jadhav P, Naik N, Sutar S, Patil D, Konde K and Patil S (2024)
Process for the production of acetic acid from neera and development of kit for detection of toddy adulteration
pp 197

Behera S, Nikam P, Pachpute H, Devkar S, Ghule V, Patil D, Konde K and Patil S (2024)
Traditional vs scientific technologies for mahua liquor production
pp 193

Behera S, Patil T, Konde K and Patil S (2024)
Sugarcane syrup production through inversion: an alternative substrate for ethanol production in sugar and allied industries
pp 196

Behera S, Sutar S, Suryawanshi S, Pawar J, Patil S, and Konde K and Patil S (2024)
Process for microbial gluconic acid production: a value addition to the sugar industry
pp 180

Deshmukh V, Nikam P, Patil D and Konde K (2024)
Cane juice/syrup to ethanol: opportunities for dryer technology in distillery
pp 192

Gaikwad K, Burase RV and Sutar S (2024)
CBG opportunity in sugar industry: Biomethanation of press mud cake for biogas production
pp 171

Godage R, Nikam P, Deshmukh V and Konde K (2024)
Advanced technologies for distillery plant and its downstream processes
pp 193

Havale S, Naik N, More S and Konde K (2024)
Separation of cation and anion by ion-chromatography technique
pp 199

Naik N, Ghule V, Havale S, Suresh NS and Konde K (2024)
Malt spirit maturation study by using advance analytical techniques
pp 198

Nikam P, Behera S, Godage R and Konde K (2024)
CBG production opportunities in sugar & allied industry
pp 177

Patil D, Behera S, Patil S, Nikam P and Konde K (2024)
Bioprospecting of sugarcane juice for ethanol production
pp. 190

Patil S, Nalawade K, Saikia P, Patil S, Sutar S, Behera S, Konde K and Patil S (2024)
Valorisation of sugarcane bagasse for l-lactic acid production
pp. 179

Patil S, Nikam P, Behera S, Mane P and Konde K (2024)
Prospects of hydrogen production in sugar & allied industry
pp 178

Patil D, Nitesh M and Konde K (2024)
Cost Benefit Analysis: Production of Ethanol from Grains & Sugarcane-Based Feedstock
pp 191

Patil S, Patil S, Gore R, Patil J and Konde K (2024)
Wax recovery from press mud cake: Value addition product for sugar industry
pp 181

Sutar S, Patil S, Behera S, Konde K and Patil S (2024)
Process development for second generation (2G) ethanol production through enzymatic route
pp 175,

Konde K, Patil D, Behra S and Nikam P (2023)
Critical Investigations in sugar juice to ethanol production. 55th Annual Convention of SISSTA

ENVIRONMENTAL SCIENCES

Poster/Abstract Presentation in Conference

The following technical poster presented in the 3rd International Conference and Exhibition at VSI during 12th - 14th January 2024

Alhat EP, Uphade KU, Nimbalkar DS and Sawarkar AS (2024)
Excess sugar condensate is an alternative source of fresh water.
pp 212

Buyyakar AS, Sapte AD and Kad PB, (2024)
Bio extraction of cellulose from the sugarcane bagasse for the production of bio-leather
pp 215

Deshmane AB and Salunkhe UH (2024)
Green technology: hydrogen generation through sugar mill effluent treatment.
pp 217

Gaikwad SR, Alhat EP, Uphade KU and Nimbalkar DS (2024)
Develop the method to dispose of the dried spent wash through brick manufacturing.
pp 213

Handeshwar PS, Kad PB and Duraiswami R, (2024)
Sugarcane bagasse- based bio-char and its potential applications
pp 216

Harkar NU, Bhosale NB, Patil SS and Devatalu AG (2024)
Investigation on the transformation of waste plastic into hydrocarbon fuel via catalytic depolymerization.
pp 214



48th Foundation Day celebration with Mr. Sumit Malik, Information Commissioner, Maharashtra as Chief Guest.

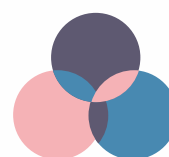



Annexure V

SEMINARS/ WORKSHOPS/ MEETINGS/TRAINING PROGRAMMES

I) SEMINARS/ WORKSHOPS/ TRAINING PROGRAMMES ORGANISED BY VSI

Date	Particulars
Apr. 7, 2023	One day training programme on 'Performance improvement of sugar mill' organized by VSI and Shahakar Maharshi Shankarrao Kolhe SSK at sugar mill site
Apr. 19-21, 2023	Training programme on 'Pollution control and waste management in distillery units' for officers of CPCB
Jun. 12-17, 2023	Short term training programme on Special Analysis in Sugar Laboratory
Jun. 19-23, 2023	Short term training programme on Juice Clarification & Evaporation
Jun. 19-23, 2023	Short term training programme on Pan boiling & Centrifugals
Jun. 19-23, 2023	Training programme on 'Fermentation and distillation processes' for distillery operators
Jun.19-23, 2023	DFPD guideline for various feed stocks diversion for ethanol production & FRP recovery calculation
Jun. 26- 28, 2023	Training programme on 'Pollution control and waste management in distillery units' for officers of CPCB
Jun.19-23, 2023	Training programme for Mill Foremen on mill operation & Maintenance and for Boiler Attendants on Boiler operation & maintenance
Jun. 26- to Jul. 7, 2023	Training programme on 'Molasses and other raw materials for production of alcohol, physical & chemical properties of alcohol and its special features, production of various alcoholic beverages etc' for Deputy Superintendent, Excise Department of Government of Maharashtra,
Jul. 31- Aug. 11, 2023	Training programme on 'Molasses and other raw materials for production of alcohol, physical & chemical properties of alcohol and its special features, production of various alcoholic beverages etc' for Joint Commissioner, Superintendent, Deputy Superintendent, Excise Department of Government of Maharashtra
Jul. 31- Aug. 2, 2023	Three-day training provided to NSL Sugars for their engineering and cogeneration technical team at Koppa, Karnataka State
Oct. 4, 2023	National Seed Day
Oct. 23- Nov. 3, 2023.	Training programme on 'Molasses and other raw materials for production of alcohol, physical & chemical properties of alcohol and its special features, production of various alcoholic beverages etc.' for Deputy Superintendent, Excise Department of Government of Maharashtra
Jan. 12-14, 2024	3 rd International conference & exhibition on "Sustainability: Challenges & Opportunities in Global Sugar Industry" organized by VSI
Feb. 24, 2024	Advanced Management Practices for Sugarcane Crop
Mar. 21-22,2024	Training programme on 'Concept of statistical design and analysis of data'
Mar. 23, 2024	One day workshop on 'Mechanical, chemical and biological management of pests in sugarcane'
Mar. 26-28, 2024	Training programme on 'Alcohol production from various raw materials and analysis of raw material and alcohol' for international delegates (Mexico) and executives from Ronsa Engineering Solutions Pvt. Ltd. Pune

**II) PARTICIPATION IN SEMINARS/WEBINARS/WORKSHOPS/TRAINING PROGRAMMES
BY VSI SCIENTISTS**

Title	Scientist(s) participated
One-Day Joint Seminar of SISSTA and SNSI on 'Promotion of Ethanol Production in the Present Scenario of the Indian Sugar Industry' at S. Nijalingappa Sugar Institute, Belagavi Apr. 1, 2023	Mr. Sambhaji Kadupatil, Mr. RA Chandgude
Webinar on Health implications due to inhalation of ultrafine particles organized by Global Council for Environment and Health Apr. 22, 2023	Mr. VS Deshmukh
Sugar Summit' Conference at Dubai May 9-10, 2023	Mr. Sambhaji Kadupatil, Dr. KS Konde
Seminar on 'Automation Technology Meet 2023' arranged by M/s Ditap-V May 10, 2023	Mr. DN Gare Mr. SG Kaduskar
National Webinar on "Future of Indian Agriculture: Challenges and Opportunities" organized by Maharana Pratap University of Agriculture and Technology, Udaipur (Rajasthan) May 22, 2023	Dr. GS Kotgire Mr. BH Pawar
National Webinar on 'Mainstreaming Agrobiodiversity –An integrated approach to reduce climate vulnerability, improve nutrition, livelihoods and ecosystem services ' organized by Maharana Pratap University of Agriculture and Technology, Udaipur (Rajasthan) May 23, 2023	Dr. GS Kotgire
51 th Joint Agresco, MPKV, Rahuri May 25, 2023	Dr. PS Deshmukh Ms. SD Ghodke
Seminar on 'Uniflow Tech Conclave 23' in arranged by M/s Uniflow Jun. 17, 2023	Mr. DN Gare Mr. SG Kaduskar
One Day Seminar on 'Gears for Sugar Industry organized by Renuka Gears at VSI, Pune Jul. 1, 2023	All Staff of Sugar Engineering Dept.
One Day Seminar on 'Production of process pumps' organized by M/s Smart Tek, Gujarat at Pune Jul. 5, 2023	Mr. SB Thorat
Seminar on 'Digital Instrumentation & Control systems' arranged by M/s Schneider Jul. 7, 2023	Mr. DN Gare
"LGC Axio PT & Global lab Solutions using proficiency testing reports to identify problem areas' Jul. 13, 2023	Mr. VP Ghule
'Revised syllabus of M.Sc. (WBAT) course first year' Gargi Agriculture Research & Training Institute, Nashik Jul. 18, 2023	Dr. RV Burase
Seminar on 'Latest solutions in distillery/ automation/ service and emphasizing importance of cyber securiry' organized by M/s ABBMr. SG Kaduskar Jul. 26, 2023	Mr. DN Gare
National Webinar on 'Bio-pesticides: Green technology in sustainable agriculture' organized by Navsari Agriculture University, Navsari, Campus Bharuch (Gujarat) Aug. 08, 2023	Dr.GS Kotgire



Annexure V (Contd.)

Title	Scientist(s) participated
Webinar cum training on 'Ecology and biodiversity for an environmental impact assessment (EIA) study' organized by Recycling and Environment Industry Association of India Aug. 19, 2023	Dr. AB Deshmane
Online Sugarcane seminar on 'Research imperatives for sustaining sugarcane, sugar and ethonol production' organized by SBI, Coimbatore Aug. 21, 2023	Mr. RG Yadav Dr. TD Shitole
One day seminar on 'Basics of lubrication and solutions for the sugar industry organized by M/s Malu Industry at VSI, Pune Sugar Engineering Dept. Aug. 21, 2023	All Staff of Sugar Engineering Dept.
81 st Annual Convention of STAI held at Travancore, Thiruvananthapuram, Kerala Sep. 6-8, 2023	Mr. Shivajrao Deshmukh Mr. Sambhaji Kadupatil Dr. KS Konde Mr. RA Chandgude Dr. JM Repale Ms. SD Ghodke Mr. PP Shinde Dr. RV Dani Mr. S Panda
Accelerating technology commercialization (ATC) of RGSTC-Funded Projects, organized by RGSTC and IIT Bombay Sep. 6-9, 2023	Dr. SS Patil
National cogeneration awards 2023 and integrated strategy for green renewable energy for sugar complexes at Pune Sep. 16, 2023	Dr. KS Konde Mr. RA Chandgude
Webinar on 'Quantitative Risk Assessment in Industry' (QRA) organized by Recycling and Environment Industry Association of India Sep. 23, 2023	Dr. EP Alhat Mr. VS Deshmukh
68 th Annual Convention and Sugar Expo of DSTA at Pune Sep. 24-25, 2023	Mr. Sambhaji Kadupatil Dr. RV Dani Mr. RA Chandgude Mr. S Panda Mr. N Mahana
52 nd Annual Convention SISSTA held at Chennai Sep. 29-30, 2023	Mr. Sambhaji Kadupatil Dr. AD Kadlag Dr. JM Repale Dr. SG Dalvi Dr. KS Konde Ms. JP Kharade Ms. SD Ghodke Mr. PP Shinde Mr. BH Pawar Mr. S Panda Mr. K Gangadharam Mr. N Mahana

Annexure V (Contd.)

Title	Scientist(s) participated
13 th Sugar Summit, Mumbai Oct. 1, 2023	Dr. KS Konde
Challenges in syrup operations and solutions' at Praj Tower, Pune Oct. 11, 2023.	Dr. KS Konde Mr. DA Patil
Training on 'Remote sensing and GIS in digital soil mapping' Nov.01- 10, 2023	Dr. SA Surwase
Workshop on 'Unleashing the power of bioeconomy' at NCL, Pune Dec. 7, 2023	Dr. KS Konde
National Symposium cum Industrial Meet on Agri-Business in Alliums:Innovations, Promotions & Sustainability held at Pune Dec. 22-23, 2023	Dr. SG Dalvi
International conference Innovations in Food Processing Technology and Nutrition Organized by Dept of Biosciences & Technology DR.V.K. MIT Peace University Pune in Collaboration with School of Food Technology& Nutrition Loyola Academy, Hyderabad Jan. 22-24, 2024	Dr. SG Dalvi
Winter School on 'Climate Smart Sugarcane Agriculture for Food and Energy Security in India' at Sugarcane Breeding Institute, Coimbatore Jan. 31 – Feb. 20, 2024	Dr. KV Sushir Dr. SD Talekar Ms. JP Kharde Ms. KG Nigade
Seminar on 'Decarbonisation @ Ground Zero' arranged by M/s Pioner Instruments Feb. 10, 2024	Mr. SG Kaduskar
Training programme on Measures to improve sugar quality and Various steps to be taken to reduce sugar losses at Victoria Milling Company Philippines Feb, 18 – Mar. 6, 2024	Mr. K Gangadharam, Mr. RR Patil
One-day joint seminar on 'Modern technology and energy efficient equipment and machinery for the energy economy' organized by SISSTA in association with SEDL and Ponni Sugars (Erode) at K.S. Rangasamy College of Technology, Tiruchengode, Tamil Nadu Mar. 16, 2024	Mr. Sambhaji Kadupatil Mr. RA Chandgude Mr. PG Patil Mr. AP Dhage
Training on 'Getting Started with Mapping and Visualization' by ESRI Mar. 27, 2024	Ms. P Kad
Training on 'Creating a Knowledge Graph from Structured Data Using ArcGIS Knowledge' by ESRI Mar. 27, 2024	Ms. P Kad
Online one-day workshop on “Literature Search” organized by Savitribai Phule Pune University , Pune Mar. 30, 2024.	Library staff



Annexure V (Contd.)

III) PARTICIPATION IN MEETINGS BY VSI SCIENTISTS

Title	Scientist(s) participated
Pre RFRC meeting at Dept of PPAM, MPKV Rahuri Apr. 13, 2023	Ms. SD Ghodke Ms. KG Nigade
RFRC meeting at Dept of PPAM, MPKV Rahuri Apr. 13, 2023	Ms. SD Ghodke
Research Review Committee and Research Planning Meeting at MPKV, Rahuri Apr. 18- 20, 2023,	Dr. AS Patil Dr. GR Pawar
Online meeting with Botanical Water Technologies Australia, Natural Sugar U1, Agrowon on availability of water from sugar cane. Apr. 21, 2023	Dr. RV Dani
Research Review meeting (RRC), MPKV, Rahuri Apr. 24, 2023	Dr. RS Hapase Dr. JM Repale Mr. AB Gawhane
RFRC, Meeting, MPKV, Rahuri Apr. 25, 2023.	Dr. PS Deshmukh
Research Finding Release Committee (RFRC), MPKV, Rahuri Apr. 29, 2023	Dr. RS Hapase Dr. JM Repale Mr. AB Gawhane
Meeting with Chairman M.D., W.M., P.M. of Shree Datta Shetkari SSK, Shirol at Vanrai, Pune with representative of SIDEL Global Environmental LLC, U.S.A. on particulate emission collector system. May 5, 2023	Dr. RV Dani
Online meeting of BoS in Environmental Science, Kavayitri Bahniabai Chaudhari North Maharashtra University, Jalgaon May 17, 2023	Dr. DS Nimbalkar
Joint Agresco meeting, MPKV, Rahuri for Pre-release proposal of CoVSI 18121 May 26- 28, 2023 Meeting with Ex. Minister Sugar & Textile, Karnataka State in VSI regarding refined sugar production. May 31, 2023	Dr. RS Hapase Mr. AB Gawhane Dr. RV Dani
Meeting to discuss the emerging issues in sugar and distillery industries and their probable solutions. Online meeting organized by Central Pollution Control Board Jun. 1, 2023	Dr. DS Nimbalkar Dr. RV Dani Mr. DB Sapkal Mr. LS Dalvi Dr. EP Alhat Dr. VP Patil Mr. KA Uphade Mr. NU Harkar
Meeting at Rajarambapu SSK Jun. 13, 2023	Dr. PS Deshmukh
Online meeting between VSI and IIT, Powai at meeting room on use of Artificial Intelligence in sugar industry. Jun. 26, 2023	Dr. RV Dani Mr. K Gangadharam
Meeting with Kirloskar Brothers at VSI on Refurbishment Technology for sugar industry Jun. 27, 2023	Dr. RV Dani

Annexure V (Contd.)

Title	Scientist(s) participated
MoU agenda discussion meeting with Director, ICAR- NRCG, Pune Jun. 28, 2023	Dr. AD Kadlag, Dr. SG Dalvi
Online meeting of BoS in Environmental Science, News Arts Commerce and Science College, Ahmednagar Jun. 28, 2023	Dr. DS Nimbalkar
Online meeting with SAMEER (R&D) team Mumbai regarding Online brix sensor Jul. 3, 2023	Dr. RV Dani
Online meeting of BoS in Environmental Science, Kavayitri Bahniabai Chaudhari North Maharashtra University, Jalgaon Jul.7, 2023	Dr. DS Nimbalkar
Meeting at TIH Foundation, Mumbai Jul. 25, 2023	Dr.PS Deshmukh
Meeting with sugar commissioner and other officials at Sakhar Sankul regarding regular recovery calculation and FRP recovery calculation details during diversion of various feedstocks. Jul. 28,2023	Dr. RV Dani Mr. ST Chavan Mr. RR Patil
Virtual meeting with Maharashtra State technical education authorities regarding new Certificate course in Quality Control in Lab Technician Aug. 3, 2023	Dr. RV Dani
MoU Closure Meeting at BARC, Mumbai Aug. 30, 2023	Mr. Sambhaji Kadupatil, Dr. AD Kadlag Dr. SG Dalvi Dr. AS Patil, Dr. RM Devarumath
Discussion at MPCB for microwave, MPCB, Sion, Mumbai, Sep. 12, 2023	Dr. SG Dalvi
Revision of M.Sc. Environmental Sciences syllabus, meeting of BoS in Environmental Sciences, SPPU Pune Sep. 23, 2023	Dr. DS Nimbalkar
Meeting on Artificial Intelligence (AI) in Sugarcane Agriculture, Vidya Prathishthan, Baramati Sep. 29, 2023	Dr. AS Patil Dr. SD Talekar Mr. US Manjul Mr. RG Yadav
MOU agenda discussion meeting with BAIF researchers Oct. 3, 2023	Dr. SG Dalvi
MOU-Progress Review meeting at DBSKKV Dapoli. Oct. 9-10, 2023	Mr. Sambhaji Kadupatil, Dr. AD Kadlag Dr. SG Dalvi, Dr. KS Konde, Mr. Kotkar
AICRP(S) group meeting at Dr. Rajendra Prasad Central Agricultural University, Pusa, Samastipur, Bihar. Oct. 26-27, 2023	Dr. JM Repale Mr. BH Pawar Mr. RG Yadav Dr. AS Patil Dr. SA Surwase



Annexure V (Contd.)

Title	Scientist(s) participated
Updating of B.Sc. Environmental Sciences syllabus, meeting of BoS in Environmental Sciences, SPPU Pune Nov. 7, 2023	Dr. DS Nimbalkar
Meeting with Director (Admin) and Asst. Director (Finance) at Commissioner of Sugar Office on F.M.% cane for diverted feed stocks. Nov. 8, 2023	Dr. RV Dani Mr. ST Chavan
Meeting with delegation from Philippines regarding raw sugar production process & other departments with their respective subject at VSI. Nov. 20, 2023	Dr. RV Dani Mr. ST Chavan Mr. K Gangadharam Mr. N Mahana Mr. RR Patil Mr. RN Ghorpade
Meeting with Dr. Bhosale Director (Administration), Commissioner of Sugar, Pune at VSI regarding feed stock diversion & FRP recovery training program progress. Nov. 21, 2023	Dr. RV Dani Mr. ST Chavan Mr. RR Patil Mr. RN Ghorpade
High Level Review Committee of Electron Beam Center for technologies developed at BARC, Mumbai Dec. 2, 2023	Dr. SG Dalvi
Participation in Board of studies meeting at DBSKKV, Dapoli Jan. 16-17, 2024	Dr. SG Dalvi
Research Review Committee and Research Planning Meeting at MPKV, Rahuri Jan. 17 -19, 2024	Dr. AS Patil Dr. GR Pawar
Online- Zonal breeders and Plant Protection Scientist Meet- 2023 Jan. 19, 2024	Dr. TD Shitole
Recategorisation of sugar industries into orange and green category. Online meeting organized by Central Pollution Control Board Jan. 19, 2024	Dr. DS Nimbalkar Dr. VP Patil Mr. KA Uphade Mr. NU Harkar
Meeting with Dy. CM & Commissioner of Sugar on problems faced by the sugar mills due to recent notification issued by Director - Sugar & recent New DFPD guidelines at VIP rest house, Pune Jan. 20, 2024	Dr. RV Dani Mr. RR Patil
Research Planning Meeting, MPKV, Rahuri Jan. 22, 2024	Dr. GS Kotgire
RRC meeting at MPKV, Rahuri Jan. 23, 2024	Dr. TD Shitole
Research Planning Meeting at MPKV, Rahuri Jan. 24, 2024	Dr. GS Kotgire
Signing MoU with VNMKV, Parbhani Feb. 5-6, 2024	Dr. AD Kadlag Dr. SG Dalvi
Hybrid mode Zonal Breeders & Plant Protection Scientists meet 2023 held at IISR, Lucknow Feb. 16, 2024	Mr. BH Pawar Dr. GS Kotgire
Research Review Committee and Research Planning Meeting at MPKV, Rahuri Mar. 18 -19, 2024	Dr. AS Patil Dr. GR Pawar
Pre-RRC meeting at DBSKKV, Dapoli Mar. 20-21, 2024	Dr. SG Dalvi
RRC meeting at DBSKKV, Dapoli Mar. 22, 2024	Dr. SG Dalvi
Online meeting of BoS in Environmental Science, News Arts Commerce and Science College, Ahmednagar Mar. 27, 2024	Dr. DS Nimbalkar

LECTURES DELIVERED BY VISITORS AT VSI

Date	Subject	Name of the speaker/ Organization
Feb. 24, 2024	Sugarcane Based Floral Intercropping System	Dr. KV Prasad, Director, DFR, Manjari, Pune
Mar. 23, 2024	Novel technologies for management of insect pests in sugarcane	Dr. YA Thorat, Scientist, ICAR, Center for Biological Control, Pravaranagar, Ahmednagar
May 11, 2023	National Technology Day	Dr. Rajendra Shende, Founder Director, Green TERE Foundation, Pune
Jun. 21, 2023	Microbioreactor -Bioelectrol XT	Mr. Jagdish Bennale, Market Development Specialist, Beckman Coulter Life Sciences, USA
Aug. 1, 2023	Sugarcane juice & syrup storability study	Mr. Pierre Noel, Business Development Manager, Sugar & Ethanol, DE SMET, Belgium

INVITED LECTURES BY VSI SCIENTISTS

Date	Subject	Place	Speaker
May 30, 2023	Training regarding BH molasses diversion as per DFPD Guidelines	Shree Mahuva Pradesh Sahakari Khand Udyog Mandli, Gujarat	Mr. N Mahana
Jul. 6, 2023	Sugarcane ratoon management	RAMETI, Alandi, Pune	Dr. AS Patil
Jul. 6, 2023	Management of pest in sugarcane	RAMETI, Alandi, Pune	Mr. RG Yadav
Jul. 6, 2023	Integrated management of sugarcane diseases	RAMETI, Alandi, Pune	Dr. GS Kotgire
Jul. 19-21, 2023	Training programme on Sugar Processing for technical staff	NSL Sugar Ltd. Koppa, Karnataka	Mr. K Gangadharam Mr. RR Patil
Aug 8, 2023	Sugarcane Crop management	Kandar, Tembhurni, Solapur	Dr. AS Patil
Aug. 11, 2023	Sugarcane Crop management	Vilas SSK, Unit I, Latur	Dr. GR Pawar
Aug. 29, 2023	Advanced planting methods of sugarcane and ratoon management	Dr. babasaheb Ambedkar SSK, Osmanbad	Dr. GR Pawar
Sep.13, 2023	Soil sample collection	Krishi Tirth Nursery, Islampur Sangali	Dr. SA Surwase
Oct. 23, 2023	Calculations for FRP Recovery during diversion of BH molasses	Pandurang SSK, Solapur	Mr. ST Chavan, Mr. N Mahana, Mr. RN Ghorpade
Oct. 25, 2023	Calculations for FRP Recovery during diversion of BH molasses	Sangamner SSK, Ahmednagar	Mr. ST Chavan, Mr. N Mahana, Mr. RN Ghorpade
Oct. 25, 2023	Calculations for FRP Recovery during diversion of BH molasses	Rajarambapu Patil SSK	Mr. ST Chavan, Mr. K Gangadharam Mr. RN Ghorpade
Oct. 30, 2023	Calculations for FRP Recovery during diversion of BH molasses	Malegaon SSK, Baramati	Mr. S Panda, Mr. N Mahana, Mr. RR Patil
Dec. 1, 2023	Calculations for FRP Recovery during diversion of BH molasses	V.V.D. Manjara SSK, Latur	Mr. S Panda, Mr. RR Patil Mr. RN Ghorpade



Annexure VII (Contd.)

INVITED LECTURES BY VSI SCIENTISTS

Date	Subject	Place	Speaker
Dec. 5, 2023	Calculations for FRP Recovery during diversion of BH molasses	K.A.Tope Samarth SSK, Unit I, Jalna	Mr. K Gangadharam, Mr. RR Patil Mr. RN Ghorpade
Dec. 7, 2023	Integrated Nutrient Management in Sugarcane	Krishi Tirth Nursery, Islampur (Sangali)	Dr. PS Deshmukh
Dec. 9, 2023	Advanced ratoon management practices	Islampur, Sangli	Dr. AS Patil
Dec. 9, 2023	Training regarding BH molasses diversion as per DFPD Guidelines	Shree Madhi Vibhag Khand Udyog Mandali, Gujrat	Mr. N Mahana
Dec. 22-23, 2023	National Symposium cum Industrial Meet on Agri-Business in Alliums: Innovations, Promotions & Sustainability	Organized by Maratha Chamber of Commerce & Agriculture, Pune and Directorate of Onion and Garlic Research Rajgurunagar	Dr. SG Dalvi
Dec. 28-30, 2023	Sugarcane crop management for higher productivity	Karmveer Shankarrao Kale SSK	Dr. AS Patil
Jan. 22-24, 2024	Synergizing Gamma Radiations and Natural Polymers: A Novel Approach to Enhance Agricultural Sustainability Amidst Climate Challenges	International conference Innovations in Food Processing Technology and Nutrition Organized by Dept. of Biosciences & Technology DR.V.K. MIT Peace University Pune in Collaboration with School of Food Technology & Nutrition Loyola Academy, Hyderabad	Dr. SG Dalvi
Mar. 12, 2024	Crop management under adverse climatic conditions	Sahyadri SSK, Karad	Dr. AS Patil
Mar. 22, 2024	Crop management under water stress conditions	Kisanveer SSK, Satara	Dr. AS Patil
Mar. 22, 2024	Management of pest in sugarcane	Kisanveer SSK, Satara	Dr. TD Shitole



Inauguration of *Oos Sheti Dnyanyag* training programme



Inauguration of *Oos Sheti Dnyanlaxmi* training programme

RADIO AND TELEVISION PROGRAMMES

Date	Topic	Name of Scientist
All India Radio		
May 18, 2023	<i>Awarshangrasta Paristhitimadye Oos Pikasathi Pani Niyojan</i>	Mr. PP Shinde
May 27, 2023	<i>Karyashyam Pani Vaparasathi Rengan Tushar Sinchan Piddhati</i>	Mr. PP Shinde
Jun. 16, 2023	<i>Oosatil pandarya mashi aani Humniche ekatmik niyentran</i>	Dr. TD Shitole
Jul. 5, 2023	<i>Adsali Oos Sheti Kami Kharchyat Kashi Karal</i>	Mr. BJ Takalkar
Jul. 07, 2023	<i>Pavasala hangamat oos pikavar adhalnare rog va tyanche niyantran'</i>	Mr. BH Pawar
July. 11, 2023	<i>Oos pikat panawar adhalnare rog tyache mahatv aani niyentran</i>	Dr. GS Kotgire
Jul. 21, 2023	<i>Humniche ekatmik niyentran</i>	Mr. RG Yadav
Aug. 2, 2023	<i>Anterpike and niyojan</i>	Dr. AS Patil
Aug. 2, 2023	<i>Oos pikatil tan vyavsthapan</i>	Dr. AS Patil
Aug. 8, 2023	<i>Adsali Oos Sheti Arthikdrushta Kifayatshir Karnyavha Upay Yojana</i>	Mr. BJ Takalkar
Aug. 11, 2023	<i>Vasantdada Sugar Instituteche Shashwat Oos Shetisathi Karya</i>	Mr. Sambhaji Kadupatil Director General
Oct. 20, 2023	<i>Oosavaril khod kid v kadikidiche ekatmik niyentran aani pithe kid v khavale kid niyentran</i>	Mr. RG Yadav
Nov. 29, 2023	<i>Oos benyadware pasarnare rog ani tyache niyantran</i>	Dr. GS Kotgire
Dec. 7, 2023	<i>Utti Savardhan Tantradnyanacha Oos shetisathi vapar</i>	Dr. RA Sawant
Dec. 14, 2024	<i>Oos utpadanamadhe mashagatiche mahatva</i>	Dr. GR Pawar
Dec. 14, 2024	<i>Suru hangam oos lagwad</i>	Dr. GR Pawar
Jan. 18, 2024	<i>Oos pik roganche ekatmikritya niyantran</i>	Mr. BH Pawar
Jan. 18, 2024	<i>Oos Pikavar adhalnare vishanujanya rog va upay</i>	Mr. BH Pawar
Feb. 3, 2024	<i>Maze Ghar Maze Shet - Oos Pikakavaril rog va Kidicheche Jaivik Nitrayan</i>	Mr. BG Mali
Feb. 3, 2024	<i>Maze Ghar Maze Shet - Oos Sheti Madhe Jivanu Khatacha Vapar</i>	Mr. BG Mali
Feb. 5, 2024	<i>Yantrik Paddhtine Oos Lagwad</i>	Mr. PP Shinde
Feb. 12, 2024	<i>Suru Oos lagwad Kami Kharchayat Karnyache Niyogen</i>	Mr. BJ Takalkar
Feb. 19, 2024	<i>Oos Todani Yantracha Vapar and Mahatwa</i>	Mr. PP Shinde
Feb. 26, 2024	<i>Kami Khrchache Khodwa Peek</i>	Mr. BJ Takalkar
Doordarshan		
Apr. 17, 2023	<i>Oosasathi rasaynik khatache vyavasthapan</i>	Ms. JP Kharade
May 17, 2023	<i>Sendriya sheti madhe jivanu khatanacha vapar - Krushidarshan</i>	Ms. KG Nigade
Oct. 17, 2023	<i>Maharashtratil Oos Lagvadisathi Shifarasit Jaati</i>	Dr. JM Repale
Nov. 6, 2023	<i>Khodvyatil pachat vyavsthapan - Krushidarshan</i>	Mr. BG Mali
Dec.12, 2023	<i>Oosavaril roganच्या niytranasathi pratibandhatmak upay</i>	Dr. GS Kotgire
Jan 05, 2024	<i>Oos Shetimadhe VSIchi Bharari</i>	Mr. Sambhaji Kadupatil Director General

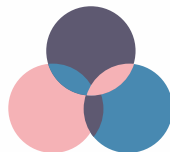



AWARDS

Award	Awardees	Article
Sharakarashri Award from NSI Kanpur	Dr. RV Dani	Alumni meet of National Sugar Institute, Kanpur
Gold Medal award for manufacturing section of 80th Annual convention of STAI-2022.	Dr. RV Dani & Mr. S Panda	“Raw Sugar production for export & potentiality for sale in domestic market
Silver Medal for manufacturing section of 51 st Annual convention of SISSTA-2022.	Mr. N Mahana Mr. S Panda Dr. RV Dani	“Spontaneous Combustion of Molasses- Problems & Remedies”
Silver Medal for manufacturing section of 51 st Annual convention of SISSTA-2022.	Mr. S Panda, Mr. RR Patil, Mr. RN Ghorpade, Dr. RV Dani	“Advanced Raw sugar process to sustain shelf life & suitable to domestic consumption”.
Best technical paper 1 st prize for manufacturing section of 67 th Annual convention of DSTA-2022.	Mr. S Panda Mr. RR Patil Mr. N Mahana Mr. RN Ghorpade, Dr. RV Dani	“Importance of Daily sugar balance for recovery calculation at the time of different feed stocks diversion for ethanol production”.
Silver medal for technical paper in 52 nd Annual Convention of SISTA in Chennai on September 29, 2023.	Mr. RS Hapase, Mr. JM Repale Mr. SS Karade	Performance of promising sugarcane genotypes in South Zone of Maharashtra
J. P. Mukherji Noel Deerr Gold Medal for the Best Factory Engineering Paper of the Year 2023 award received during the 81 st Annual Convention and International Sugar Expo 2023	Mr. RA Chandgude	Photovoltaic Solar Power Generation in the Sugar Industry
Silver medal received during the 52 nd Annual Convention of SISTA in Chennai on September 29, 2023.	Mr. SS Shripatanla Mr. SP Nalawade and Mr. RA Chandgude	Ameliorating juice extraction through material balance (2022)
Honoured for the Adoption of New Technologies and Innovations in the Segment of Sugar and Ethanol Industry during a one-day seminar organized by Schneider Electric and L&T at Mumbai on December 20, 2023	Mr. PG Patil	--

Award	Awardees	Article
Best Poster Awards in 3rd International Conference at VSI, Pune		
Session - Soil Sustainability : Challenges and Prioritise		
1 st Prize	Ms. JP Kharade, Dr. PS Deshmukh and Mr. SA Surwase	Growth, yield and quality response of sugarcane to micronutrient application in sugarcane growing soil
Session - Micro-irrigation and Sugarcane Mechanization		
1 st Prize	Mr. PP Shinde	Efficient water management through micro irrigation systems in sugarcane
Session - Sustainable Sugarbeet Industry - Emerging Challenges		
1 st Prize	Dr. AS Patil, Dr. GR Pawar and Dr. AD Kadlag	Technological intervention for wider adoptability of sugarbeet : A case study
Session - Microbes and Potential Bio-agents in Sustainable Sugarcane Product		
1 st Prize	Ms. SS Shinde, Mr. BG Mali and Ms. SD Ghodke	Effect of application of microbial slurry containing natural agricultural beneficial microorganisms on yield and quality of sugarcane
2 nd Prize	Ms. KG Nigade, SD Ghodke, US Manjul, DS Jadhav and Kamble KB	Bioefficacy of entomopathogenic nematode against white grub pest in Sugarcane
3 rd Prize	Ms. SD Ghodke and Mr. BG Mali	Effect of application of consortium of agriculturally beneficial soil microbes 7 microbial consortium of endophytes nitrogen fixing bacteria on yield and quality of sugarcane in nutrient exhausted soil
Session - Pest in Sugarcane : Fact and Management Approach		
1 st Prize	Mr. BH Pawar, Dr. GS Kotgire and Mr. JH Yadav	Management of brown spot disease in sugarcane
2 nd Prize	Mr. B Shinde, Mr. T Shitole and Dr. SG Dalvi	Chitosan-enhanced growth media for improved biocontrol potential of <i>Bacillus thuringiensis</i> subspecies <i>krustaki</i> : A comprehensive evaluation
Session - Modern Developments in Processing and Engineering		
2 nd Prize	Mr. RP Takale and Mr. RA Chandgude	Sustainable irrigation by using off-grid standalone solar power systems for agriculture pumps
3 rd Prize	Mr. S Panda and Dr. RV Dani	Sucrose to pol ratio evaluation an important tool to improve the sugar recovery
Session - Green Technology : Circular Bio-economy		
1 st Prize	Dr. S Patil, Mr. P Nikam, Dr. S Behera, Mr. P Mane and Dr. K Konde	Prospects of hydrogen production in sugar & allied industry
2 nd Prize	Mr. K Gaikwad, Dr. RV. Burase and Mr. S Sutar	CBG opportunity in sugar industry : Biomethanation of press mud cake for biogas production



Annexure IX (Contd.)

Award	Awardees	Article
Session - Green Technology : Circular Bio-economy		
3 rd Prize	Mr. V Deshmukh, Mr. P Nikam, Mr. D Patil and Dr. K Konde	Cane juice/syrup to ethanol : Opportunities for dryer technology in distillery
Session - Challenges and Opportunities in Bioethanol		
2 nd Prize	Dr. S Behera, Mr. T Patil, Dr. K. Konde and Dr. S Patil	Sugarcane syrup production through inversion : An alternative substrate for ethanol production in sugar and allied industries
3 rd Prize	Mr. V Deshmukh, Mr. P Nikam, Mr. D Patil, and Dr. K Konde	Cane juice/syrup to ethanol : Opportunities for dryer technology in distillery
Session - Environmental Sustainability in the Sugar and Allied Industry		
2 nd Prize	Ms. A Sapte, Ms. P Kad and Ms. A Buyyakar	Bio extraction of cellulose from the sugarcane baggase for the production of bio-leather

Ph.D. AWARDS

Name	Title of Thesis	University / Subject	Name of Guide
Mr. MS Vikharankar	Optimization, purification and evaluation of neutralizing polyclonal antibodies against COVID-19 disease	Savitribai Phule Pune University Biotechnology	Dr. RM Devarumath, VSI, Pune



PATENTS

- Method for pre-treatment of lignocellulosic biomass using recycled acid and alkali, in lactic acid production (202021008352)
- Method for pre-clarification of molasses to improve the fermentation efficiency thereof (201821039366)
- Method for pre-clarification of molasses to improve the fermentation efficiency thereof (US20200332374A1)
- Method for ethanol production from sugar by addition of spent wash as nutrient supplementation (202021025284)

Memorandum of Understanding (MoU)/

Non-Disclosure Agreement (NDA)

- MoU with TIH Foundation, Mumbai for IoT & IoE for using the IoT based real time sensing system for sugarcane growing soils of Maharashtra towards efficient nutrient management.
- MoU with K. J. Somaiya College of Science & Commerce, Mumbai for research, training and hands on experience
- MoU with GPS renewables Pvt. Ltd., Bangalore for Execution of project entitled 'Process development for an economical and sustainable lignocellulosic based ethanol production'

- MoU with Nutrition & Health Pvt. Ltd. for work on various aspects of research for ethanol production
- NDA with De Smet S.A. Engineers & Contributors (Interis), Belgium for lab tests, trials as well as drafting & delivery of related test report in respect to long term storage of properly conditioned cane syrup
- NDA with Danisco India Pvt. Ltd. (IFF) for work on biogas, ethanol & biorefineries
- MoU with Praj Industries Ltd., Pune, for work on 1G & 2G ethanol, butanol, CBG, Potash from ash, Hydrogen
- MoU with Techpert Process Industries, Pune for work on 2G ethanol plant from bamboo using alkali pretreatment & enzymatic hydrolysis
- MoU with Pernod Ricard India Pvt. Ltd., New Delhi for work various aspects such as Training, Industrial Internships, Research and Development activities, Consultancy services in the area of technical, regulatory & statutory aspect of manufacture of alcoholic beverages.



A Memorandum of Understanding (MoU) between "Technology Innovation Hub (TIH) Foundation for Internet of Things (IoT) and VSI



Training for State Excise Staff

DISTINGUISHED VISITORS

- Dr. Imad Eujayl, USDA, ARS, Kimbrley, Idaho, USA
- Mr. Richard Sauvage, Maugain, France
- Mr. Jean Noel Evrard, SeSVanderhave, Belgium
- Mr. Timothee Massion, WABCG, France
- Dr. Ashutoshkumar Mall, IISR, Lucknow
- Dr. Arjun Tayade, CCRI, Nagpur
- Dr. Mauhammad Ahmad, NRSC, Bengaluru
- Directors of Janshanti Farmers Producers Company, Nifad, Nashik
- Directors of Green Vision Farmers Producers Company, Nifad, Nashik
- Directors of Shree Siddheshwar SSK Ltd., Solapur
- Mr. Mansing Mulik & team, Kenya sugar consultant
- Dr. Z.P. Patel, Vice chancellor, Navsari Agricultural University, Navsari, Gujarat
- Dr. R. Viswanathan, Director, ICAR - Indian Institute of Sugarcane Research Lucknow, Uttar Pradesh, India
- Dr. G. P. Rao, Director, Institute of Agricultural & Natural Sciences, DDU Gorakhpur University, Gorakhpur, Uttar Pradesh, India.
- Dr S. N. Sushil, Director, ICAR-National Bureau of Agricultural Insect Resources, Hebbal, Bengaluru, Karnataka
- Dr François-Régis GOEBEL, CIRAD, Research Unit Agro-ecology and sustainable intensification of annual crops, Montpellier –France
- Dr. Yogesh E. Thorat, Scientist, IISR-Biological Control Center, Pravaranagar, Ahmednagar, Maharashtra
- Dr. Alok Pandey, Assistant Manager Sugarcane, Solidaridad Regional Expertise Center, New Delhi
- Mrs. Monika Khanna, Country Manager, Solidaridad Regional Expertise Center, New Delhi
- Dr. R. P. Singh, Sugarcane Advisor, Solidaridad Regional Expertise Center, New Delhi
- Mrs. Rama Shukla, Assistant Manager, Solidaridad Regional Expertise Center, New Delhi
- Mrs. Manisha Shah, Assistant Manager, Solidaridad Regional Expertise Center, New Delhi
- Mr. Praveen Kumar, Assistant Director, Lal Bahadur Shastri Ganna KisanSanstan, Lucknow, Uttar Pradesh, India
- Mr. Shankar B Patil, Munenkoppa, Former Sugar Minister Govt. of Karnataka
- Mr. Ravi Kumar (IAS) - Managing Director of Mysore Sugar Company, Bengaluru, (Govt of Karnataka Undertaking)
- Mr. Avinash Rastogi Under Secretary, Co-operative Department, Government of India
- Mr. Pierre Noel, Business Development Manager, Sugar & Ethanol, DE SMET
- Mr. Pierre Averseng (Senior Technologist, Interis India Pvt. Ltd.



- Mr. Ravindra Jayawant (CEO-Director, Interis India Pvt. Ltd.)
- Prof. V. V. Mahajani, Advisor RGSTC
- Fiji Sugar Corporation, Government of Fiji Islands
 - Mr. Vinod Prasad (Process Head), Mr. Anderson (Engineering Head), Mr. Shiu (Procurement Head)
- Team of Philippines
 - Mr. Alvin Yu (Chairman & Owner), Mr. Arnel Amparo (Chief Manufacturing Officer)
Mr. Marlowe Lugador (Department Manager), Mr. James Tabangcora (Unit Manager)
- **Other Visitors**

Particulars	No. of Visitors
Farmers in state	4923
Farmers outside State	30
Commissionerate of Sugar officers	11
Co-operative Department Officers	18
Pune Knowledge cluster Officers	8
CPCB Govt. of India) officers	6
Directors of Maharashtra	23
College students other than Agriculture College	2652
College Lecturers Other than Agriculture College	175
Somiya Vidya Vihar University member	11
RAWE Students	11
College Students from Agriculture College	747
Lecturers from Agriculture College	59
Total	8674



Visit of the AICRP(S) monitoring team at VSI Farm

Visits Abroad (VSI Staff)

Date	Place of Visit	Name of the staff
May 8-10, 2023	Globoil & Sugar Summit International at Dubai, UAE	Mr. Sambhaji Kadupatil Dr. KS Konde
Jun. 2-10, 2023	Electrical drive and Robotics manufacturing company, Japan for to check suitability of robotics application in sugar industry	Mr. RA Chandgude and Mr. PG Patil
Aug. 23-26, 2023	Terra Sugar Factory, Mauritius for to study sugarcane trash removal system	Mr. RA Chandgude and Mr. PG Patil

VISITS TO OTHER INSTITUTES

National

- Agriculture Development Trust's KVK Baramati, Pune
- Agriculture Research Station, Shirgaon, Ratnagiri, Maharashtra
- Agharkar Research Institute, Pune, Maharashtra
- Bhabha Atomic Research Center, Mumbai, Maharashtra
- College of Engineering, Pune, Maharashtra
- Central Potato Research Institute, Shimla, Himachal Pradesh
- Dr. Balasaheb Sawant Konkan Krishi Vidyapeeth, Dapoli, Ratnagiri, Maharashtra
- Dr. Rajendra Prasad Central Agril. University, Pusa, Bihar
- Electron Beam Research Center Kharghar Mumbai
- ICAR-Directorate of Floricultural Research (DFR), Pune, Maharashtra
- ICAR- National Bureau of Soil Survey & Land Use Planning (ICAR- NBSS&LUP), Nagpur
- ICAR – National Research Center for Grapes (NRCG), Pune
- Krishi Vigyan Kendra, Sambhajinagar, Maharashtra
- Maharashtra Pollution Control Board (MPCB), Pune/ Mumbai, Maharashtra
- Mahatma Phule Krishi Vidyapeeth (MPKV), Rahuri, Ahmednagar, Maharashtra
- National Sugar Institute (NSI), Kanpur
- Savitribai Phule Pune University (SPPU), Pune, Maharashtra
- Society for Applied Microwave Electronics Engineering and Research, Mumbai
- TIH Foundation, Mumbai
- Vidya Pratisthan, KVK, Baramati, Maharashtra



Training program on “Advanced Technologies in Sugarcane Agriculture”



Inauguration of World Conservation Day and 5th year of production of Vasant Urja



VISITS BY TECHNICAL PERSONNEL

Annexure XII

Particulars	No. of visits
Agricultural Sciences and Technology	
Research Activities	99
Farm Development and Management	02
Oos Bhushan plot verification/Prize winners	55
Hybridization, Amboli	14
Pests and Disease Management	07
Inspection of seed plots	11
Cane development activities/variety identification	04
Demonstrative/Adaptive trial	16
Participation of seminars/workshop/conference/meeting	31
Farmers rallies	25
Farmers Melava	01
Consultancy for cane development	03
Pest & Disease Management/Survey of Sugarcane insect pests	13
Other visits-Sugar beet	01
Different VSI's nt Farm visit	86
Low recovery	01
Staff training of mill officers	04
LBF consultancy to mill	00
Other (IC & E-2024)	103
Total	476
Sugar Technology	
Validation visits for BH/Syrup diversion for Ethanol production	128
GPI's Inspection	70
Extension service including modernization of sugar plant	93
Guiding the factories to improve the overall technical performance.	31
Conservation of steam, power and water	16
Research and development work	06
Off-Seasonal Maintenance Work	12
Guiding the factories for water and waste water management.	12
ETP Consultancy & adequacy assessment	12
Minimizing the sugar losses in boiling house	06
Preparation of Tender Technical Specifications, Scrutiny of Design and Drawing of Equipments	07
Conference / Seminar / Workshops	07
Improvement in sugar quality with colour audit team	01
Improvement in capacity utilization of the factories	03
Selection of candidates for technical posts in sugar factories	12
Analytical services during visit	26
Optimization of use of chemicals	00
Increasing awareness about automation of different units	00
Educational visits	10
Foreign visits	01
Other visit	00
Total	453

Annexure XII (Contd.)

Particulars	No. of visits
Sugar Engineering	
Extension services including modernization of sugar mills (VC + Offline)	201
Cogeneration projects (VC + Offline)	29
Inspection of machineries (VC + Offline)	80
Machinery manufacturers meetings (VC + Offline)	25
Non-member sugar mills	27
Pre-bid and technical committee meetings (VC + Offline)	35
SLMPC/ COS and cogeneration Coordination meetings (VC + Offline)	24
SDF / NCDC meetings (VC)	4
MSEDCL meetings (VC + Offline)	2
Research and development Projects (VC + Offline)	46
Conference / Seminar / Workshop / Training programmes (VC)	11
Distillery captive power projects	100
Other visits	25
Total	609
Alcohol Technology and Biofuels	
Academic related visits	2
Adequacy Assessment Report preparation- Evaluation of distillery ETP's performance	6
Board of Directors meetings for distillery projects	2
Biogas issue	2
Cane juice /BH molasses to ethanol production	87
Commissioner of State Excise, Mumbai, Government of Maharashtra State	2
Contract research project	4
CBG plant DPR	1
CBG plant visit	2
CPCB, GPI work	1
CBG co-ordination meeting	1
Distillery modernization proposals	1
Distillery expansion	4
Distillery plant review meeting	6
Distillery co-ordination meeting	36
Distillery co-ordination meeting for tender	1
Distillery inspection	2
Distillery modification	2
Dr. Balasaheb Sawant Konkan Krishi Vidypeeth, Dapoli	1
Evaluation of spentwash dryer technology	2
Grain base distillery plant DPR	2
Inspection of project execution and performance of distillery plants	75
Inspection of plant and machinery at vendor's workshops	12
Inspection of plant and machinery of existing distilleries	1
Interviews of distillery personnel	2
Meetings at Sugar Commissionerate office	9



Annexure XII (Contd.)

Particulars	No. of visits
Alcohol Technology and Biofuels	
MoU	2
New distillery project discussion	5
Pre-bid meeting for distillery & Effluent treatment plant	12
Panan Vibhag, Pune	1
R & D related visits	3
SLMPC meetings	7
Seminars / Workshop / Training / Others	1
Spentwash powder plant	1
Troubleshooting of process problems and related issues	7
Technical committee meeting for distillery proposal	9
Technical & Commercial bid meeting of distillery	5
Tender finalization	1
Technical audit of distillery & ETP	4
Virtual lab	1
Total	325
Environmental Sciences	
CPCB GPI	127
Technical Consultancy (ETP, CPU, STP, Adequacy & Validation work)	54
EIA related work (Public Hearing, Data collection, meetings)	07
Monitoring (Air, Water, Noise)	10
EC Compliance related work	07
Meeting at MoEFCC, MPCB, Mantralaya	02
Academic visits	01
Damage Assessment work	04
Research work	03
Other	03
Total	218
Electronics and Computer	
Demonstration of VSI sugar ERP	03
VSI sugar ERP Software installation and maintenance	200
VSI sugar ERP Software installation and maintenance to Bagamoyo Sugar Ltd. Tanzania	02
Total	205
Instrumentation	
Co-generation / Distillery Project Work	91
Rectification and Calibration Work	25
Advisory Services	06
Training/ Seminar	06
Total	128
Grand Total	2129

ABBREVIATIONS AND ACRONYMS

Annexure XIII

%	Percentage/ Percent	CoN	Coimbatore + Navsari
µg	Microgram	CoM	Coimbatore + Maharashtra
2G	Second generation	CoSNK	Coimbatore + Sankeshwar
AAR	Adequacy Assessment Report	CoR	Coimbatore+ Rudrur
AAS	Atomic absorption spectroscopy	CoVC	Coimbatore+ Visvesvaraya
ACFC	Auto Cane Feed Control	CFU	Colony Forming Unit
AICRP's	All India Coordinated Research Project on Sugarcane	CPCB	Central Pollution Control Board
AICRP	All India Coordinated Research Project	CII	Confederation of Indian Industry
AIDA	All India Distillers Association	CL	Country liquor
ADY	Active Dry Yeast	CBG	Compressed bio gas
AD	Anaerobic Digestion	CMV	Cauliflower Mosaic Virus
AICRP	All India Coordinated Research Project on Sugarcane	CNG	Compressed Natural Gas
ARI	Agharkar Research Institute	COD	Chemical oxygen demand
ARS	Agriculture Research Station	CO	Carbon monoxide
ASSCT	Australian Society of Sugarcane Technologists	CPU	Condensate Polishing Unit
ATL	Accredited Test Laboratory	CSRS	Central Sugarcane Research Station
ATMA	Agriculture Technology Management Agency	CSKHPKV	Chaudhary Sarwan Kumar Himachal Pradesh Krishi Vishvavidyalaya
AVSI	Associateship of Vasantdada Sugar Institute	CV	Coefficient of Variation
B:C	Benefit : Cost	DAP	Days after planting / Di Ammonium Phosphate
BAL	Baramati Agro Ltd.	DAR	Days after ratoon
BARC	Bhaba Atomic Research Station	DDU	Din Dayal University
BBrMV	Banana Bract Mosaic Virus	DFPD	Department of Food and Public Distribution
BBTV	Banana Bunchy Top Virus	DIFAT	Diploma in Industrial Fermentation and Alcohol Technology
BCIL	Biotechnology Consortium India Limited	DAM	Distillery Association of India
BH	B heavy	DBT	Department of Biotechnology
bp	base pair	DNA	Deoxyribonucleic acid
BSA	Bovine serum albumin	DODGR	Directorate of Onion & Garlic Research
BSV	Banana Streak Virus	Dr. BSKKV	Dr. Balasaheb Sawant Konkan Krishi Vidyapeeth
BHM	B-heavy Molasses	DFR	Directorate of Floriculture Research
BOT	Board of Trustees	DPR	Detailed Project Report
cc	Cubic Centimeter	DCS	Distributed Control System
CCS	Commercial Cane Sugar	EBP	Ethanol Blending Programme
CD	Critical Difference	EC	Electrical Conductivity/ Environmental Clearance
CFA	Central Financial Assistance	ES	Engineering Station
CFD	Computational Fluid Dynamics	ETc	Crop evapotranspiration



ABBREVIATIONS AND ACRONYMS

Annexure XIII (Contd.)

ETP	Effluent Treatment Plant	IGR	Inter Generic Hybrid
ENA	Extra Neutral Alcohol	I/O	Input / Output
EoI	Expression of Interest	IMFL	Indian Made Foreign Liquor
EPN	Entomopathogenic Nematode	INM	Integrated Nutrient Management
EU	European Union	IPM	Integrated Pest Management
FAO	Food & Agriculture Organization/ Fertilizer Control Order	ISBN	International Standard Book Number
FE	Fermentation Efficiency	ISMA	Indian Sugar Mills Association
Fig.	Figure	ISH	Interspecific Hybrid
FCO	Fertilizer Control Order	ISSCT	International Society of Sugarcane Technologists
FRP	Fair and Remunerative Price	IU	ICUMSA Unit
FSSAI	Food Safety and Standards Authority of India	ICUMSA	International Commission for Uniform Methods for Sugar Analysis
FVT	Final Varietal Trial	IVT	Inter Varietal Trial
g/gm	Gram	IW/CPE	Irrigation water (IW) to crop evapotranspiration (CPE)
GA	Gibberellic acid	JB	Junction Box
GAD	General Arrangement Drawing	JSL	Jaywant Sugars Ltd.
GC	General Collection	KLPA	Kilo Liter Per annum
GC	Gas Chromatography	KLPD	Kilo Liter Per Day
GC-MS	Gas chromatography mass spectrometry	kg	Kilogram
GoM	Government of Maharashtra	L/lit/Lit	Liter
GoMP	Government of Madhya Pradesh	Ltd.	Limited
GF	Genetic fidelity	MCCIA	Maratha Chamber of Commerce Industries and Agriculture
GoI	Government of India	MED	Multiple effect distillation
GPIs	Grossly Polluted Industries	MEDC	Maharashtra Economic Development Cooperation
GSD	Grassy Shoot Disease	MHAT	Moist Hot Air Treatment
Ha	Hectare	ml	Milliliter
HPLC	High pressure liquid chromatography	mm	Millimeter
hr	Hour	mM	Milli molar
HR	Hand Refractometer	MoU	Memorandum of Understanding
IAA	Indole-3-acetic acid	MLT	Multilocation trials
IARI	Indian Agriculture Research Institute	MLSS	Mixed Liquor Suspended Solids
IASLIC	Indian Association of Special Libraries & information Centres	MPCB	Maharashtra Pollution Control Board
ICAR	Indian Council of Agricultural Institute	MPKV	Mahatma Phule Krishi Vidyappeth
CSSRI	Central Soil Salinity Research Institute	MPUAT	Maharana Pratap University and Technology
ICSB	International Consortium of Sugarcane Biotechnology	MP	Madhya Pradesh
IISR	Indian Institute of Sugarcane Research	MS	Maharashtra State
I&C	Instrumentation & Control		
IC	Ion Chromatography		

ABBREVIATIONS AND ACRONYMS

MW	Megawatts	PDKV	Punjabrao Deshmukh Krishi Vidyapeeth
NAAC	National Assessment and Accreditation Council	PDN	Padegaon
NABCB	National Accreditation Board for Certification Bodies	PFR	Pre-feasibility report
NABL	National Accreditation Board for Testing and Calibration Laboratories	PESO	Petroleum and explosives safety organization
NAU	Navsari Agriculture University	PFD	Process flow Diagram
NBS	New Brunswick Scientific	P & ID	Process and Instrumentation Diagram
NCIM	National Collection of Industrial Microorganisms	PLC	Programmable Logic Controller
NCMRWF	National Centre for Medium Range Weather Forecasting	PMI	Positive material identification
NBSS/ILU	National Bureau of Soil Survey & Land Use Planning	PSA	Principal Scientific Adviser
NCIM	National Collection of Industrial Microorganisms	PF	Pre-fermenter
NCL	National Chemical Laboratory	PMC	Press mud cake
NCS-TCP	National Certification System for Tissue Culture Raised Plants	ppm	Part per million
NFCFS	National Federation for Co-operative Sugar Factories	QCI	Quality control of India
NFSM	National Food Security Mission	R&D	Research & Development
NGO's	Non Government Organization	RDF	Recommended dose of fertilizer
NIASM	National Institute of Abiotic Stress Management	RAMETI	Regional Agriculture Management Extension Training Institute
NIPB	National Institute of Plant Biotechnology	RGSTC	Rajiv Gandhi Science and Technology Commission
NIPGR	National Institute of Plant Genome Research	RPM/rpm	Revolutions per minute
NMC	Number of millable cane	RS & JRS	Regional Sugarcane & Jaggery Research Station
NMHCs	Non-methane hydrocarbons	RS	Rectified Spirit
NMCG	National Mission for Clean Ganga	RRC	Research Review Committee
NRCG	National Research Centre for Grapes	RRRNA	Raja Rammohun Roy National Agency
NSI	National Sugar Institute	RVF	Rotary Vacuum Filter
OS	Operating Station	SAU's	State Agricultural University's
P & ID	Process and Instrumentation Diagram	SAMEER	Society for Applied Microwave Electronics Engineering and Research
P&I	Piping & Instrumentation	SBC	Sugarcane Breeding Center
PC	Polycross	SBI	Sugarcane Breeding Institute
PCR	Polymerase chain reaction	SCB	Sugarcane bagasse
PDC	Percent Disease control	ScLV	Sugarcane Leaf Virus
PDI	Percent Disease Incidence	SCADA	Supervisory Control & Data Acquisition
		SATAT	Sustainable Alternative towards Affordable Transportation
		SLMPC	State Level Machinery Purchase Committee
		SISSTA	South Indian Sugarcane and Sugar Technologist's Association



ABBREVIATIONS AND ACRONYMS

SPPU	Savitribai Phule Pune University	USDA	United State Department of Agriculture
Spp.	Species	USL	United Spirits Ltd.
STTP	Short Term Training Programme	UPS	Uninterrupted power supply
STAI	Sugar Technologist's Association of India	VI	Virus indexing
SSK	Sahakari Sakhar Karkhana	VOCs	Volatile organic compounds
SSRD	Society for Sugarcane Research and Development	VSI	Vasantdada Sugar institute
Std	Standard	vWa	Valorization of waste
T	Tonnes	WABCG	World Association of Beet & Cane Growers
TC	Trichogramm chinosis	WBAT	Wine, Brewing and Alcohol Technology
TCD	Tons of Cane per Day	wp	Wet table powder
t/ha	Tons per hectare	WG	Wettable granules
TNC	The Nature Conservancy	YLD	Yellow Leaf Disease
TP	Trichogramm pretiosum	ZLD	Zero Liquid Discharge
TRS	Total reducing sugar	ZVT	Zonal Varietal Trial
TS	Total solids		



The 75th Republic Day Celebrated at VSI





संशोधनेन संवृद्धिः

Vasantdada Sugar Institute

Manjari Bk., Pin 412 307; Dist. Pune, Maharashtra, India.

Phone: (020) 26902100, Fax: (020) 26902244

E-mail: admin@vsisugar.org.in

Website: www.vsisugar.com